

For KCC Use:
Effective Date: _____
District # _____
SGA? Yes No

NOTICE OF INTENT TO DRILL

Must be approved by KCC five (5) days prior to commencing well

Form KSONA-1, Certification of Compliance with the Kansas Surface Owner Notification Act, MUST be submitted with this form.

Expected Spud Date: _____
month day year

OPERATOR: License# _____
Name: _____
Address 1: _____
Address 2: _____
City: _____ State: _____ Zip: _____ + _____
Contact Person: _____
Phone: _____

CONTRACTOR: License# _____
Name: _____

Well Drilled For: Oil Gas Seismic ; _____ # of Holes Other: _____
Well Class: Enh Rec Storage Disposal Infield Pool Ext. Wildcat Other _____
Type Equipment: Mud Rotary Air Rotary Cable

If OWWO: old well information as follows:
Operator: _____
Well Name: _____
Original Completion Date: _____ Original Total Depth: _____

Directional, Deviated or Horizontal wellbore? Yes No
If Yes, true vertical depth: _____
Bottom Hole Location: _____
KCC DKT #: _____

Spot Description: _____
_____ - _____ - _____ Sec. _____ Twp. _____ S. R. _____ E W
(Q/Q/Q/Q) _____ feet from N / S Line of Section
_____ feet from E / W Line of Section
Is SECTION: Regular Irregular?

(Note: Locate well on the Section Plat on reverse side)
County: _____

Lease Name: _____ Well #: _____
Field Name: _____

Is this a Prorated / Spaced Field? Yes No

Target Formation(s): _____

Nearest Lease or unit boundary line (in footage): _____

Ground Surface Elevation: _____ feet MSL

Water well within one-quarter mile: Yes No

Public water supply well within one mile: Yes No

Depth to bottom of fresh water: _____

Depth to bottom of usable water: _____

Surface Pipe by Alternate: I II

Length of Surface Pipe Planned to be set: _____

Length of Conductor Pipe (if any): _____

Projected Total Depth: _____

Formation at Total Depth: _____

Water Source for Drilling Operations:
 Well Farm Pond Other: _____

DWR Permit #: _____
(Note: Apply for Permit with DWR)

Will Cores be taken? Yes No
If Yes, proposed zone: _____

AFFIDAVIT

The undersigned hereby affirms that the drilling, completion and eventual plugging of this well will comply with K.S.A. 55 et. seq.

It is agreed that the following minimum requirements will be met:

- 1. Notify the appropriate district office **prior** to spudding of well;
- 2. A copy of the approved notice of intent to drill **shall be** posted on each drilling rig;
- 3. The minimum amount of surface pipe as specified below **shall be set** by circulating cement to the top; in all cases surface pipe **shall be set** through all unconsolidated materials plus a minimum of 20 feet into the underlying formation.
- 4. If the well is dry hole, an agreement between the operator and the district office on plug length and placement is necessary **prior to plugging**;
- 5. The appropriate district office will be notified before well is either plugged or production casing is cemented in;
- 6. If an ALTERNATE II COMPLETION, production pipe shall be cemented from below any usable water to surface within **120 DAYS** of spud date. Or pursuant to Appendix "B" - Eastern Kansas surface casing order #133,891-C, which applies to the KCC District 3 area, alternate II cementing must be completed within 30 days of the spud date or the well shall be plugged. **In all cases, NOTIFY district office** prior to any cementing.

Submitted Electronically

For KCC Use ONLY
API # 15 - _____
Conductor pipe required _____ feet
Minimum surface pipe required _____ feet per ALT. I II
Approved by: _____
This authorization expires: _____
(This authorization void if drilling not started within 12 months of approval date.)
Spud date: _____ Agent: _____

Remember to:

- File Certification of Compliance with the Kansas Surface Owner Notification Act (KSONA-1) with Intent to Drill;
- File Drill Pit Application (form CDP-1) with Intent to Drill;
- File Completion Form ACO-1 within 120 days of spud date;
- File acreage attribution plat according to field proration orders;
- Notify appropriate district office 48 hours prior to workover or re-entry;
- Submit plugging report (CP-4) after plugging is completed (within 60 days);
- Obtain written approval before disposing or injecting salt water.
- If well will not be drilled or permit has expired (See: authorized expiration date) please check the box below and return to the address below.

Well will not be drilled or Permit Expired Date: _____
Signature of Operator or Agent: _____



For KCC Use ONLY
API # 15 - _____

IN ALL CASES PLOT THE INTENDED WELL ON THE PLAT BELOW

In all cases, please fully complete this side of the form. Include items 1 through 5 at the bottom of this page.

Operator: _____
Lease: _____
Well Number: _____
Field: _____
Number of Acres attributable to well: _____
QTR/QTR/QTR/QTR of acreage: _____ - _____ - _____ - _____

Location of Well: County: _____
_____ feet from N / S Line of Section
_____ feet from E / W Line of Section
Sec. _____ Twp. _____ S. R. _____ E W

Is Section: Regular or Irregular

If Section is Irregular, locate well from nearest corner boundary.

Section corner used: NE NW SE SW

PLAT

Show location of the well. Show footage to the nearest lease or unit boundary line. Show the predicted locations of lease roads, tank batteries, pipelines and electrical lines, as required by the Kansas Surface Owner Notice Act (House Bill 2032). You may attach a separate plat if desired.

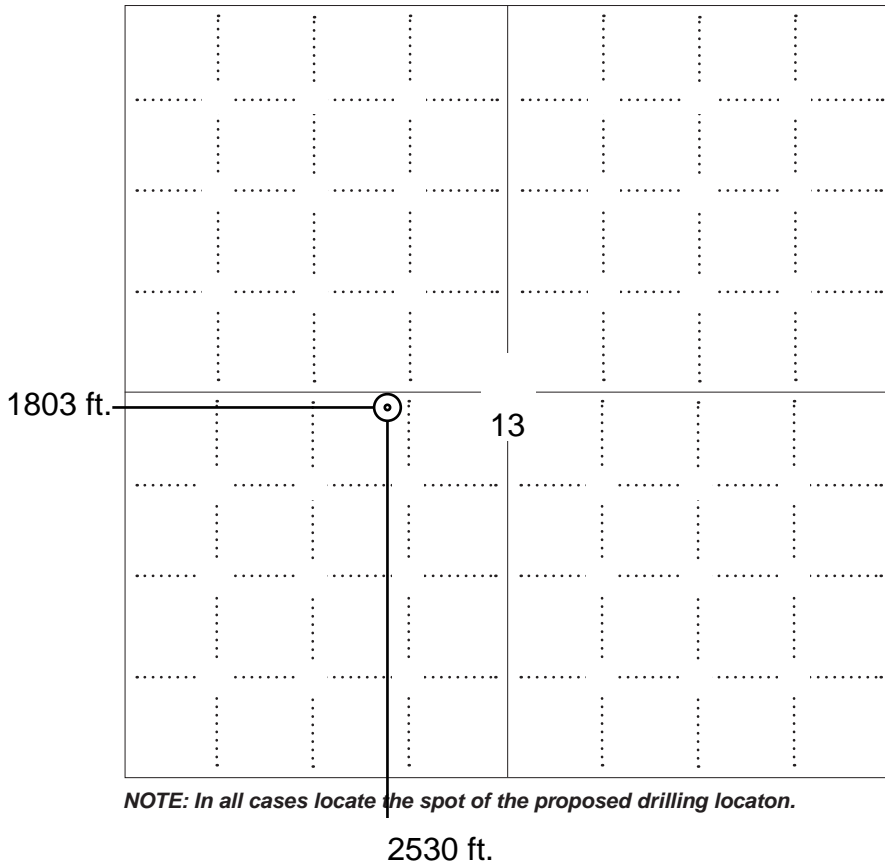

NOTE: In all cases locate the spot of the proposed drilling location.

LEGEND

- Well Location
- Tank Battery Location
- Pipeline Location
- Electric Line Location
- Lease Road Location

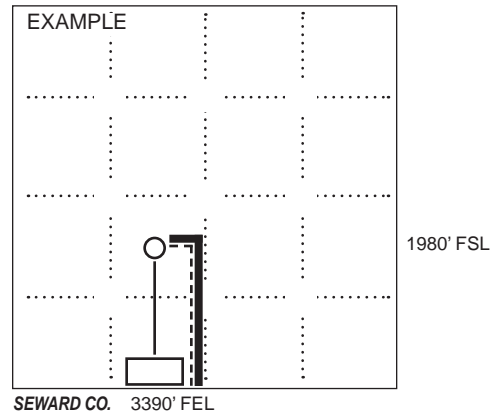

In plotting the proposed location of the well, you must show:

1. The manner in which you are using the depicted plat by identifying section lines, i.e. 1 section, 1 section with 8 surrounding sections, 4 sections, etc.
2. The distance of the proposed drilling location from the south / north and east / west outside section lines.
3. The distance to the nearest lease or unit boundary line (in footage).
4. If proposed location is located within a prorated or spaced field a certificate of acreage attribution plat must be attached: (C0-7 for oil wells; CG-8 for gas wells).
5. The predicted locations of lease roads, tank batteries, pipelines, and electrical lines.

**APPLICATION FOR SURFACE PIT***Submit in Duplicate*

Operator Name:		License Number:	
Operator Address:			
Contact Person:		Phone Number:	
Lease Name & Well No.:		Pit Location (QQQQ): ____ - ____ - ____ - ____	
Type of Pit: <input type="checkbox"/> Emergency Pit <input type="checkbox"/> Burn Pit <input type="checkbox"/> Settling Pit <input type="checkbox"/> Drilling Pit <input type="checkbox"/> Workover Pit <input type="checkbox"/> Haul-Off Pit <i>(If WP Supply API No. or Year Drilled)</i>		Pit is: <input type="checkbox"/> Proposed <input type="checkbox"/> Existing If Existing, date constructed: _____ Pit capacity: _____ (bbls)	
Is the pit located in a Sensitive Ground Water Area? <input type="checkbox"/> Yes <input type="checkbox"/> No		Chloride concentration: _____ mg/l <i>(For Emergency Pits and Settling Pits only)</i>	
Is the bottom below ground level? <input type="checkbox"/> Yes <input type="checkbox"/> No		Artificial Liner? <input type="checkbox"/> Yes <input type="checkbox"/> No	
How is the pit lined if a plastic liner is not used?			
Pit dimensions (all but working pits): _____ Length (feet) _____ Width (feet) <input type="checkbox"/> N/A: Steel Pits Depth from ground level to deepest point: _____ (feet) <input type="checkbox"/> No Pit			
If the pit is lined give a brief description of the liner material, thickness and installation procedure.		Describe procedures for periodic maintenance and determining liner integrity, including any special monitoring.	
Distance to nearest water well within one-mile of pit: _____ feet Depth of water well _____ feet		Depth to shallowest fresh water _____ feet. Source of information: <input type="checkbox"/> measured <input type="checkbox"/> well owner <input type="checkbox"/> electric log <input type="checkbox"/> KDWR	
Emergency, Settling and Burn Pits ONLY: Producing Formation: _____ Number of producing wells on lease: _____ Barrels of fluid produced daily: _____ Does the slope from the tank battery allow all spilled fluids to flow into the pit? <input type="checkbox"/> Yes <input type="checkbox"/> No		Drilling, Workover and Haul-Off Pits ONLY: Type of material utilized in drilling/workover: _____ Number of working pits to be utilized: _____ Abandonment procedure: _____ _____ Drill pits must be closed within 365 days of spud date.	
Submitted Electronically			

KCC OFFICE USE ONLY
 Liner Steel Pit RFAC RFAS

 Date Received: _____ Permit Number: _____ Permit Date: _____ Lease Inspection: Yes No

**CERTIFICATION OF COMPLIANCE WITH THE
KANSAS SURFACE OWNER NOTIFICATION ACT**

This form must be submitted with all Forms C-1 (Notice of Intent to Drill); CB-1 (Cathodic Protection Borehole Intent); T-1 (Request for Change of Operator Transfer of Injection or Surface Pit Permit); and CP-1 (Well Plugging Application). Any such form submitted without an accompanying Form KSONA-1 will be returned.

Select the corresponding form being filed: C-1 (Intent) CB-1 (Cathodic Protection Borehole Intent) T-1 (Transfer) CP-1 (Plugging Application)

OPERATOR: License # _____

Name: _____

Address 1: _____

Address 2: _____

City: _____ State: _____ Zip: _____ + _____

Contact Person: _____

Phone: (_____) _____ Fax: (_____) _____

Email Address: _____

Well Location:

____ - ____ - ____ - ____ Sec. ____ Twp. ____ S. R. ____ East West

County: _____

Lease Name: _____ Well #: _____

If filing a Form T-1 for multiple wells on a lease, enter the legal description of the lease below:

Surface Owner Information:

Name: _____

Address 1: _____

Address 2: _____

City: _____ State: _____ Zip: _____ + _____

When filing a Form T-1 involving multiple surface owners, attach an additional sheet listing all of the information to the left for each surface owner. Surface owner information can be found in the records of the register of deeds for the county, and in the real estate property tax records of the county treasurer.

If this form is being submitted with a Form C-1 (Intent) or CB-1 (Cathodic Protection Borehole Intent), you must supply the surface owners and the KCC with a plat showing the predicted locations of lease roads, tank batteries, pipelines, and electrical lines. The locations shown on the plat are preliminary non-binding estimates. The locations may be entered on the Form C-1 plat, Form CB-1 plat, or a separate plat may be submitted.

Select one of the following:

I certify that, pursuant to the Kansas Surface Owner Notice Act (House Bill 2032), I have provided the following to the surface owner(s) of the land upon which the subject well is or will be located: 1) a copy of the Form C-1, Form CB-1, Form T-1, or Form CP-1 that I am filing in connection with this form; 2) if the form being filed is a Form C-1 or Form CB-1, the plat(s) required by this form; and 3) my operator name, address, phone number, fax, and email address.

I have not provided this information to the surface owner(s). I acknowledge that, because I have not provided this information, the KCC will be required to send this information to the surface owner(s). To mitigate the additional cost of the KCC performing this task, I acknowledge that I am being charged a \$30.00 handling fee, payable to the KCC, which is enclosed with this form.

If choosing the second option, submit payment of the \$30.00 handling fee with this form. If the fee is not received with this form, the KSONA-1 form and the associated Form C-1, Form CB-1, Form T-1, or Form CP-1 will be returned.

I Submitted Electronically

For KCC Use ONLY

API # 15 - _____

IN ALL CASES PLOT THE INTENDED WELL ON THE PLAT BELOW

In all cases, please fully complete this side of the form. Include items 1 through 5 at the bottom of this page.

Operator: _____

Lease: _____

Well Number: _____

Field: _____

Number of Acres attributable to well: _____

QTR/QTR/QTR/QTR of acreage: _____ - _____ - _____ - _____

Location of Well: County: _____

_____ feet from N / S Line of Section

_____ feet from E / W Line of Section

Sec. _____ Twp. _____ S. R. _____ E W

Is Section: Regular or Irregular

If Section is Irregular, locate well from nearest corner boundary.

Section corner used: NE NW SE SW

PLAT

Show location of the well. Show footage to the nearest lease or unit boundary line. Show the predicted locations of lease roads, tank batteries, pipelines and electrical lines, as required by the Kansas Surface Owner Notice Act (House Bill 2032). You may attach a separate plat if desired.

Pawnee 1803' FWL

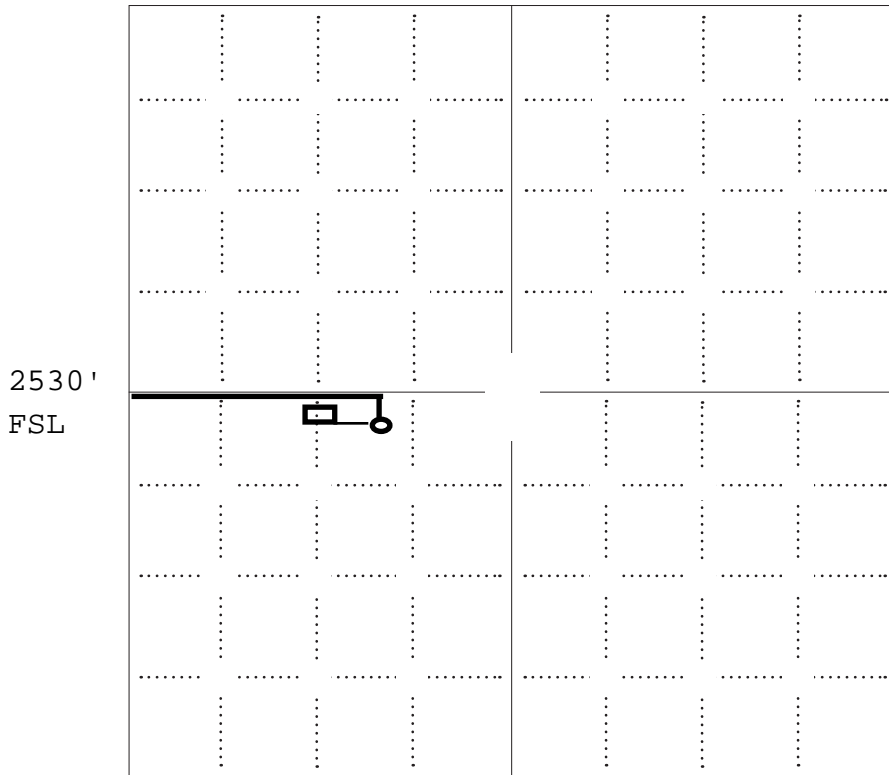

LEGEND

- Well Location
- Tank Battery Location
- Pipeline Location
- Electric Line Location
- Lease Road Location

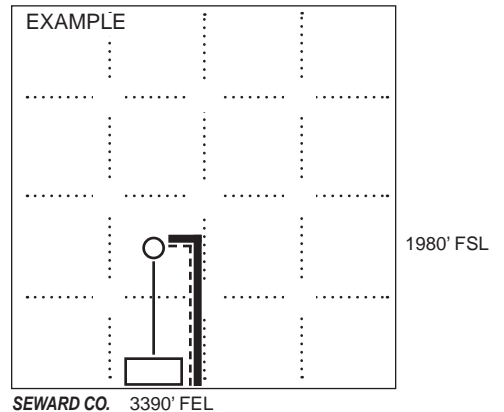

NOTE: In all cases locate the spot of the proposed drilling locaton.

In plotting the proposed location of the well, you must show:

1. The manner in which you are using the depicted plat by identifying section lines, i.e. 1 section, 1 section with 8 surrounding sections, 4 sections, etc.
2. The distance of the proposed drilling location from the south / north and east / west outside section lines.
3. The distance to the nearest lease or unit boundary line (in footage).
4. If proposed location is located within a prorated or spaced field a certificate of acreage attribution plat must be attached: (C0-7 for oil wells; CG-8 for gas wells).
5. The predicted locations of lease roads, tank batteries, pipelines, and electrical lines.

Summary of Changes

Lease Name and Number: F-N Unit 1b

API/Permit #: 15-145-21663-00-00

Doc ID: 1073124

Correction Number: 1

Approved By: Rick Hestermann 02/01/2012

Field Name	Previous Value	New Value
Feet to Nearest Water Well Within One-Mile of Pit	709	737
KCC Only - Approved By	Rick Hestermann 12/14/2011	Rick Hestermann 02/01/2012
KCC Only - Approved Date	12/14/2011	02/01/2012
KCC Only - Date Received	12/13/2011	01/31/2012
KCC Only - Lease Inspection	Yes	No
LocationInfoLink	https://solar.kgs.ku.edu/kcc/detail/locationInformation.cfm?section=13&t1853	https://solar.kgs.ku.edu/kcc/detail/locationInformation.cfm?section=13&t1803
Number of Feet East or West From Section Line	1853	1803
Number of Feet East or West From Section Line	1853	1803
Number of Feet North or South From Section Line	2510	2530
Number of Feet North or South From Section Line	2510	2530

Summary of changes for correction 1 continued

Field Name	Previous Value	New Value
Save Link	../../../../kcc/detail/operatorEditDetail.cfm?docID=1070171	../../../../kcc/detail/operatorEditDetail.cfm?docID=1073124
Well Number	1	1b

Summary of Attachments

Lease Name and Number: F-N Unit 1b

API: 15-145-21663-00-00

Doc ID: 1073124

Correction Number: 1

Approved By: Rick Hestermann 02/01/2012

Attachment Name

F-N Unit #1b-ksona