



For KCC Use:
 Effective Date: _____
 District # _____
 SGA? Yes No

KANSAS CORPORATION COMMISSION 1087775
OIL & GAS CONSERVATION DIVISION

Form C-1
 March 2010

Form must be Typed
Form must be Signed
All blanks must be Filled

NOTICE OF INTENT TO DRILL

Must be approved by KCC five (5) days prior to commencing well

Form KSONA-1, Certification of Compliance with the Kansas Surface Owner Notification Act, MUST be submitted with this form.

Expected Spud Date: _____
month day year

OPERATOR: License# _____
 Name: _____
 Address 1: _____
 Address 2: _____
 City: _____ State: _____ Zip: _____ + _____
 Contact Person: _____
 Phone: _____

CONTRACTOR: License# _____
 Name: _____

Well Drilled For:	Well Class:	Type Equipment:
<input type="checkbox"/> Oil	<input type="checkbox"/> Enh Rec	<input type="checkbox"/> Infield
<input type="checkbox"/> Gas	<input type="checkbox"/> Storage	<input type="checkbox"/> Pool Ext.
	<input type="checkbox"/> Disposal	<input type="checkbox"/> Wildcat
<input type="checkbox"/> Seismic ; _____ # of Holes	<input type="checkbox"/> Other	<input type="checkbox"/> Mud Rotary
<input type="checkbox"/> Other: _____		<input type="checkbox"/> Air Rotary
		<input type="checkbox"/> Cable
<input type="checkbox"/> If OWWO: old well information as follows:		

Operator: _____
 Well Name: _____
 Original Completion Date: _____ Original Total Depth: _____

Directional, Deviated or Horizontal wellbore? Yes No
 If Yes, true vertical depth: _____
 Bottom Hole Location: _____
 KCC DKT #: _____

Spot Description: _____
 _____ - _____ - _____ Sec. _____ Twp. _____ S. R. _____ E W
(Q/Q/Q/Q) _____ feet from N / S Line of Section
 _____ feet from E / W Line of Section

Is SECTION: Regular Irregular?
 (Note: Locate well on the Section Plat on reverse side)

County: _____
 Lease Name: _____ Well #: _____

Field Name: _____
 Is this a Prorated / Spaced Field? Yes No

Target Formation(s): _____
 Nearest Lease or unit boundary line (in footage): _____

Ground Surface Elevation: _____ feet MSL
 Water well within one-quarter mile: Yes No

Public water supply well within one mile: Yes No
 Depth to bottom of fresh water: _____

Depth to bottom of usable water: _____
 Surface Pipe by Alternate: I II

Length of Surface Pipe Planned to be set: _____
 Length of Conductor Pipe (if any): _____

Projected Total Depth: _____
 Formation at Total Depth: _____

Water Source for Drilling Operations:
 Well Farm Pond Other: _____

DWR Permit #: _____
 (Note: Apply for Permit with DWR)

Will Cores be taken? Yes No
 If Yes, proposed zone: _____

AFFIDAVIT

The undersigned hereby affirms that the drilling, completion and eventual plugging of this well will comply with K.S.A. 55 et. seq.

It is agreed that the following minimum requirements will be met:

1. Notify the appropriate district office **prior** to spudding of well;
2. A copy of the approved notice of intent to drill **shall be** posted on each drilling rig;
3. The minimum amount of surface pipe as specified below **shall be set** by circulating cement to the top; in all cases surface pipe **shall be set** through all unconsolidated materials plus a minimum of 20 feet into the underlying formation.
4. If the well is dry hole, an agreement between the operator and the district office on plug length and placement is necessary **prior to plugging**;
5. The appropriate district office will be notified before well is either plugged or production casing is cemented in;
6. If an ALTERNATE II COMPLETION, production pipe shall be cemented from below any usable water to surface within **120 DAYS** of spud date. Or pursuant to Appendix "B" - Eastern Kansas surface casing order #133,891-C, which applies to the KCC District 3 area, alternate II cementing must be completed within 30 days of the spud date or the well shall be plugged. **In all cases, NOTIFY district office** prior to any cementing.

Submitted Electronically

<p>For KCC Use ONLY</p> <p>API # 15 - _____</p> <p>Conductor pipe required _____ feet</p> <p>Minimum surface pipe required _____ feet per ALT. <input type="checkbox"/> I <input type="checkbox"/> II</p> <p>Approved by: _____</p> <p>This authorization expires: _____ <small>(This authorization void if drilling not started within 12 months of approval date.)</small></p> <p>Spud date: _____ Agent: _____</p>
--

Remember to:

- File Certification of Compliance with the Kansas Surface Owner Notification Act (KSONA-1) with Intent to Drill;
- File Drill Pit Application (form CDP-1) with Intent to Drill;
- File Completion Form ACO-1 within 120 days of spud date;
- File acreage attribution plat according to field proration orders;
- Notify appropriate district office 48 hours prior to workover or re-entry;
- Submit plugging report (CP-4) after plugging is completed (within 60 days);
- Obtain written approval before disposing or injecting salt water.
- If well will not be drilled or permit has expired (See: authorized expiration date) please check the box below and return to the address below.

Well will not be drilled or Permit Expired Date: _____
 Signature of Operator or Agent: _____

E
 W



1087775

For KCC Use ONLY

API # 15 - _____

IN ALL CASES PLOT THE INTENDED WELL ON THE PLAT BELOW

In all cases, please fully complete this side of the form. Include items 1 through 5 at the bottom of this page.

Operator: _____

Lease: _____

Well Number: _____

Field: _____

Number of Acres attributable to well: _____

QTR/QTR/QTR/QTR of acreage: _____ - _____ - _____ - _____

Location of Well: County: _____

_____ feet from N / S Line of Section

_____ feet from E / W Line of Section

Sec. _____ Twp. _____ S. R. _____ E W

Is Section: Regular or Irregular

If Section is Irregular, locate well from nearest corner boundary.

Section corner used: NE NW SE SW

PLAT

Show location of the well. Show footage to the nearest lease or unit boundary line. Show the predicted locations of lease roads, tank batteries, pipelines and electrical lines, as required by the Kansas Surface Owner Notice Act (House Bill 2032). You may attach a separate plat if desired.

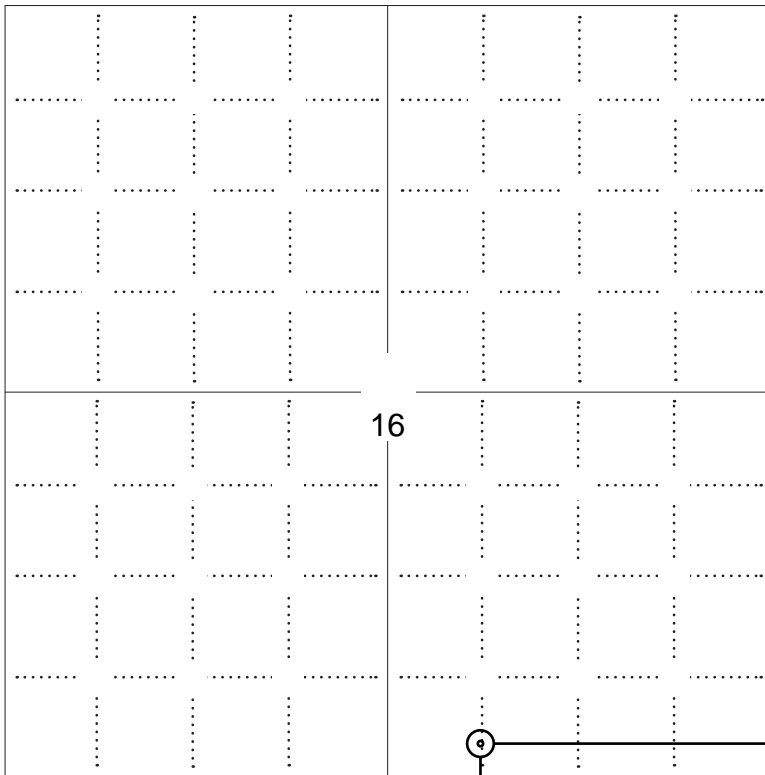

LEGEND

- Well Location
- Tank Battery Location
- Pipeline Location
- Electric Line Location
- Lease Road Location

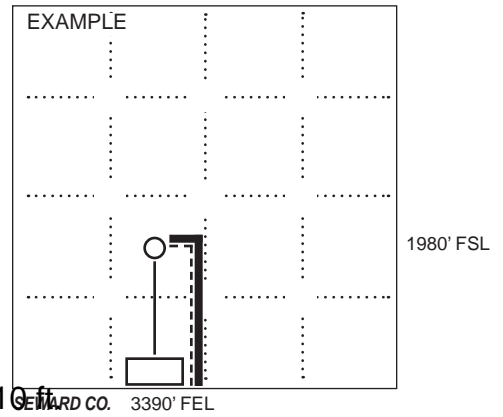

NOTE: In all cases locate the spot of the proposed drilling locaton.

235 ft.

In plotting the proposed location of the well, you must show:

1. The manner in which you are using the depicted plat by identifying section lines, i.e. 1 section, 1 section with 8 surrounding sections, 4 sections, etc.
2. The distance of the proposed drilling location from the south / north and east / west outside section lines.
3. The distance to the nearest lease or unit boundary line (in footage).
4. If proposed location is located within a prorated or spaced field a certificate of acreage attribution plat must be attached: (C0-7 for oil wells; CG-8 for gas wells).
5. The predicted locations of lease roads, tank batteries, pipelines, and electrical lines.



KANSAS CORPORATION COMMISSION 1087775
OIL & GAS CONSERVATION DIVISION

Form CDP-1
May 2010
Form must be Typed

APPLICATION FOR SURFACE PIT

Submit in Duplicate

Operator Name:		License Number:	
Operator Address:			
Contact Person:		Phone Number:	
Lease Name & Well No.:		Pit Location (QQQQ): ____ - ____ - ____ - ____	
Type of Pit: <input type="checkbox"/> Emergency Pit <input type="checkbox"/> Burn Pit <input type="checkbox"/> Settling Pit <input type="checkbox"/> Drilling Pit <input type="checkbox"/> Workover Pit <input type="checkbox"/> Haul-Off Pit <i>(If WP Supply API No. or Year Drilled)</i>		Pit is: <input type="checkbox"/> Proposed <input type="checkbox"/> Existing If Existing, date constructed: _____ Pit capacity: _____ (bbls)	
Is the pit located in a Sensitive Ground Water Area? <input type="checkbox"/> Yes <input type="checkbox"/> No		Chloride concentration: _____ mg/l <i>(For Emergency Pits and Settling Pits only)</i>	
Is the bottom below ground level? <input type="checkbox"/> Yes <input type="checkbox"/> No		Artificial Liner? <input type="checkbox"/> Yes <input type="checkbox"/> No	
How is the pit lined if a plastic liner is not used?			
Pit dimensions (all but working pits): _____ Length (feet) _____ Width (feet) <input type="checkbox"/> N/A: Steel Pits Depth from ground level to deepest point: _____ (feet) <input type="checkbox"/> No Pit			
If the pit is lined give a brief description of the liner material, thickness and installation procedure.		Describe procedures for periodic maintenance and determining liner integrity, including any special monitoring.	
Distance to nearest water well within one-mile of pit: _____ feet Depth of water well _____ feet		Depth to shallowest fresh water _____ feet. Source of information: <input type="checkbox"/> measured <input type="checkbox"/> well owner <input type="checkbox"/> electric log <input type="checkbox"/> KDWR	
Emergency, Settling and Burn Pits ONLY: Producing Formation: _____ Number of producing wells on lease: _____ Barrels of fluid produced daily: _____ Does the slope from the tank battery allow all spilled fluids to flow into the pit? <input type="checkbox"/> Yes <input type="checkbox"/> No		Drilling, Workover and Haul-Off Pits ONLY: Type of material utilized in drilling/workover: _____ Number of working pits to be utilized: _____ Abandonment procedure: _____ _____ Drill pits must be closed within 365 days of spud date.	
<p>Submitted Electronically</p>			

KCC OFFICE USE ONLY			
Date Received: _____		Permit Number: _____	
Permit Date: _____		Lease Inspection: <input type="checkbox"/> Yes <input type="checkbox"/> No	
<input type="checkbox"/> Liner		<input type="checkbox"/> Steel Pit <input type="checkbox"/> RFAC <input type="checkbox"/> RFAS	



CERTIFICATION OF COMPLIANCE WITH THE KANSAS SURFACE OWNER NOTIFICATION ACT

This form must be submitted with all Forms C-1 (Notice of Intent to Drill); CB-1 (Cathodic Protection Borehole Intent); T-1 (Request for Change of Operator Transfer of Injection or Surface Pit Permit); and CP-1 (Well Plugging Application). Any such form submitted without an accompanying Form KSONA-1 will be returned.

Select the corresponding form being filed: C-1 (Intent) CB-1 (Cathodic Protection Borehole Intent) T-1 (Transfer) CP-1 (Plugging Application)

OPERATOR: License # _____
Name: _____
Address 1: _____
Address 2: _____
City: _____ State: _____ Zip: _____ + _____
Contact Person: _____
Phone: (_____) _____ Fax: (_____) _____
Email Address: _____

Well Location: _____
_____ - _____ - _____ Sec. _____ Twp. _____ S. R. _____ East West
County: _____
Lease Name: _____ Well #: _____

If filing a Form T-1 for multiple wells on a lease, enter the legal description of the lease below:

Surface Owner Information:

Name: _____
Address 1: _____
Address 2: _____
City: _____ State: _____ Zip: _____ + _____

When filing a Form T-1 involving multiple surface owners, attach an additional sheet listing all of the information to the left for each surface owner. Surface owner information can be found in the records of the register of deeds for the county, and in the real estate property tax records of the county treasurer.

If this form is being submitted with a Form C-1 (Intent) or CB-1 (Cathodic Protection Borehole Intent), you must supply the surface owners and the KCC with a plat showing the predicted locations of lease roads, tank batteries, pipelines, and electrical lines. The locations shown on the plat are preliminary non-binding estimates. The locations may be entered on the Form C-1 plat, Form CB-1 plat, or a separate plat may be submitted.

Select one of the following:

- I certify that, pursuant to the Kansas Surface Owner Notice Act (House Bill 2032), I have provided the following to the surface owner(s) of the land upon which the subject well is or will be located: 1) a copy of the Form C-1, Form CB-1, Form T-1, or Form CP-1 that I am filing in connection with this form; 2) if the form being filed is a Form C-1 or Form CB-1, the plat(s) required by this form; and 3) my operator name, address, phone number, fax, and email address.
- I have not provided this information to the surface owner(s). I acknowledge that, because I have not provided this information, the KCC will be required to send this information to the surface owner(s). To mitigate the additional cost of the KCC performing this task, I acknowledge that I am being charged a \$30.00 handling fee, payable to the KCC, which is enclosed with this form.

If choosing the second option, submit payment of the \$30.00 handling fee with this form. If the fee is not received with this form, the KSONA-1 form and the associated Form C-1, Form CB-1, Form T-1, or Form CP-1 will be returned.

I Submitted Electronically

I

THIS DRAWING DOES NOT REPRESENT A BOUNDARY SURVEY. DISTANCES, COORDINATES AND BEARINGS SHOWN ARE NOT INTENDED TO BE DEFINITIVE IN ESTABLISHING ACTUAL TITLE BOUNDRIES. THIS DWAWING IS FOR CONSTRUCTION PURPOSES ONLY.

All Bearings, Distances, and Coordinates shown hereon are based on the Kansas State Plane Coordinate System, N.A.D. 27 Datum, South Zone.

**PROPOSED
SURFACE LOCATION
2010' FEL & 235' FSL
OF SECTION 16**

LAT: 37.956196
LON: -97.214376
X: 2370664
Y: 472092
ELEV: 1438'

1/2"IRF
LAT:37.970075
LON:-97.225818
X:2367296
Y:477100

LAT:37.970069
LON:-97.207471
X:2372585
Y:477171

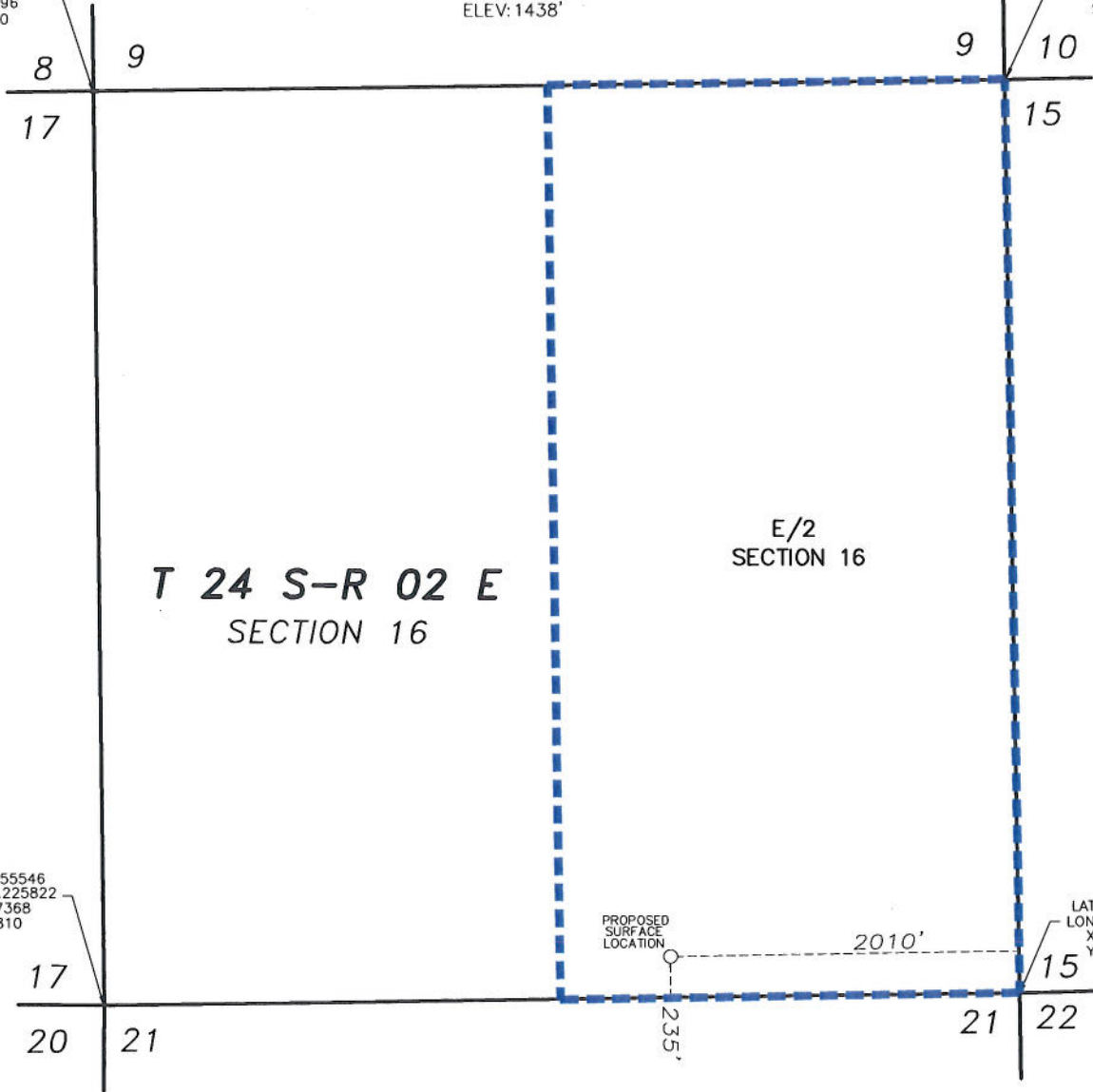

**T 24 S-R 02 E
SECTION 16**

**E/2
SECTION 16**

LAT:37.955546
LON:-97.225822
X:2367368
Y:471810

LAT:37.955553
LON:-97.207404
X:2372677
Y:471885

----- = UNIT LINE

FINAL COPY

**PROPOSED WELL LOCATION
ENCANA OIL & GAS (USA) INC.
NATTIER 16V-1 SWD
HARVEY COUNTY, KANSAS
SCALE: 1" = 1000'**

T 24 S - R 02 E

SECTION 16

SW/4 OF SE/4

SURFACE OWNER
SIDNEY A NATTIER

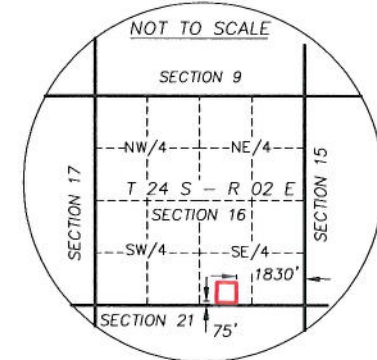
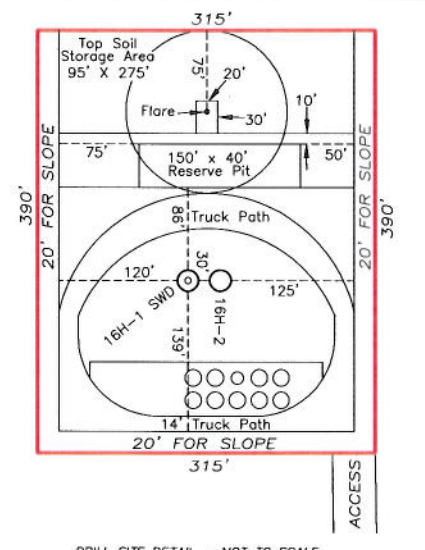
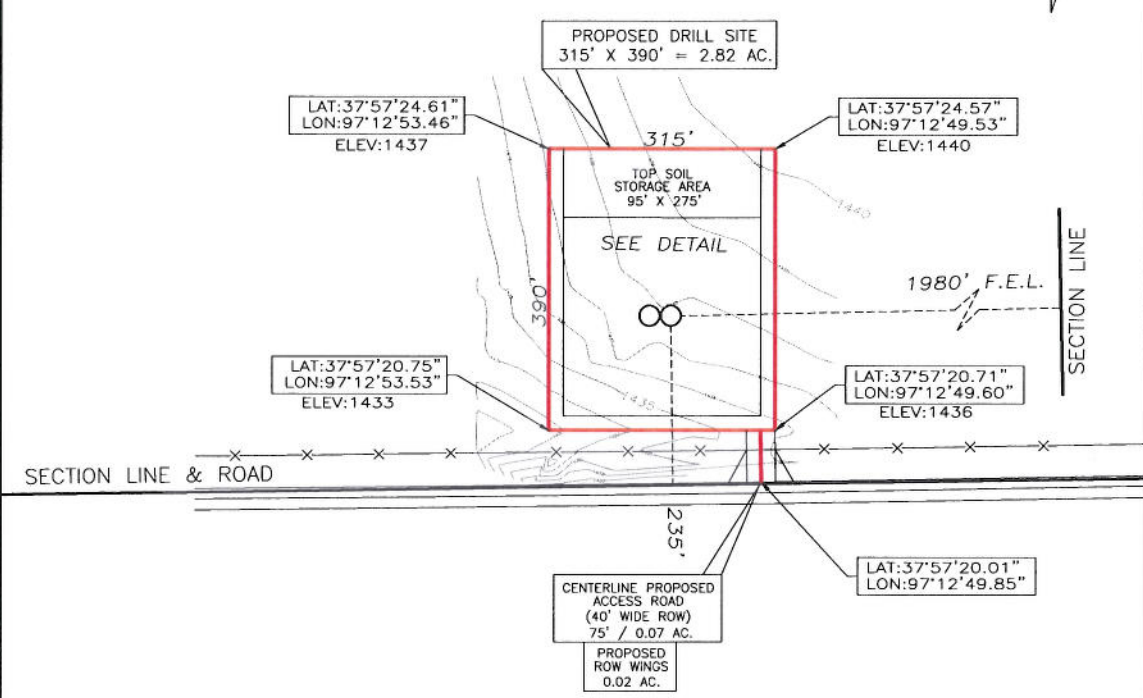

FINAL COPY

**CONSTRUCTION PLAT
SHOWING PROPOSED
DRILL SITE AND ACCESS ROAD
ENCANA OIL & GAS (USA) INC.
SECTION 16, 24S-02E, SWSE
HARVEY COUNTY, KANSAS
SCALE: 1" = 200'**

ROW WINGS = 0.02 AC.
ACCESS ROAD = 0.07 AC.
DRILL SITE = 2.82 AC.
TOTAL = 2.91 AC.

REV: 7-4-2012
7-2-2012
T120481-CON

T 24 S - R 02 E

SECTION 16

SW/4 OF SE/4

SURFACE OWNER
SIDNEY A NATTIER

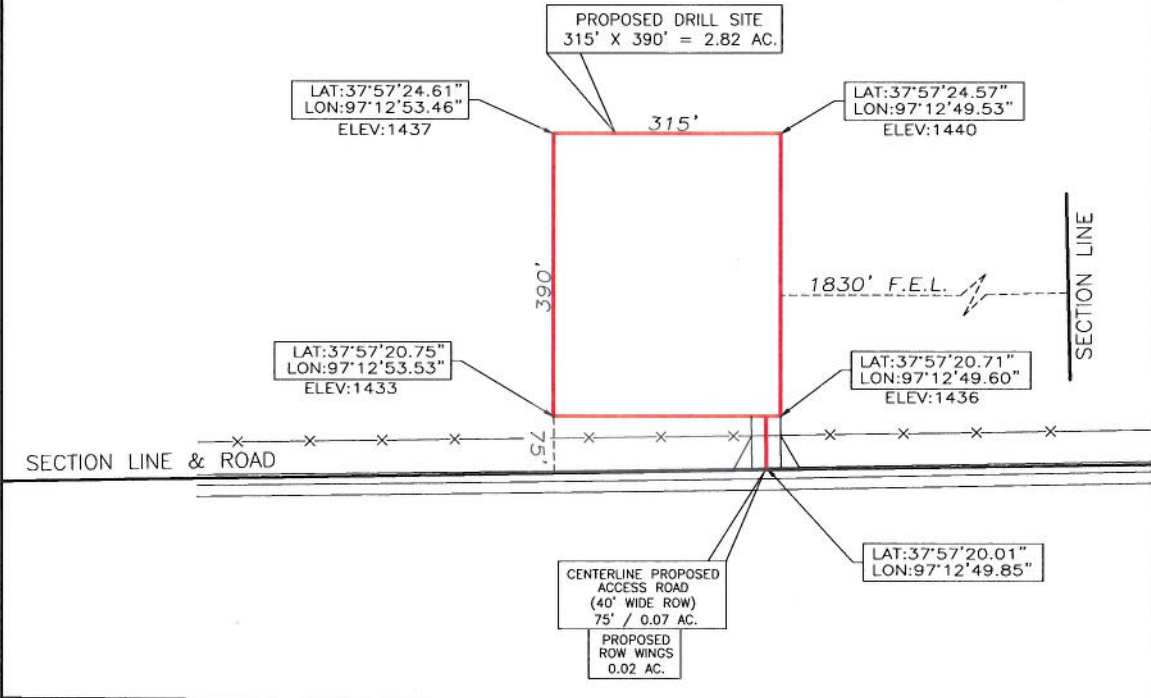

FINAL COPY

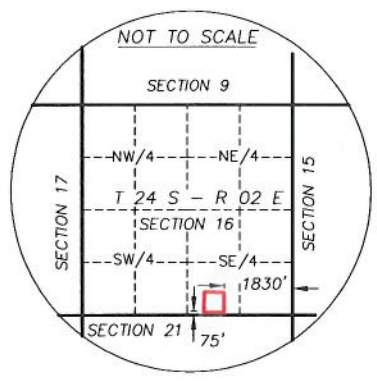

**LAND USE PLAT
SHOWING PROPOSED
DRILL SITE AND ACCESS ROAD
ENCANA OIL & GAS (USA) INC.
SECTION 16, 24S-02E, SWSE
HARVEY COUNTY, KANSAS
SCALE: 1" = 200'**

ROW WINGS = 0.02 AC. ACCESS ROAD = 0.07 AC. DRILL SITE = 2.82 AC.
TOTAL = 2.91 AC.

REV: 7-4-2012
7-2-2012
T120481-LU

Nattier 16V-1 SWD

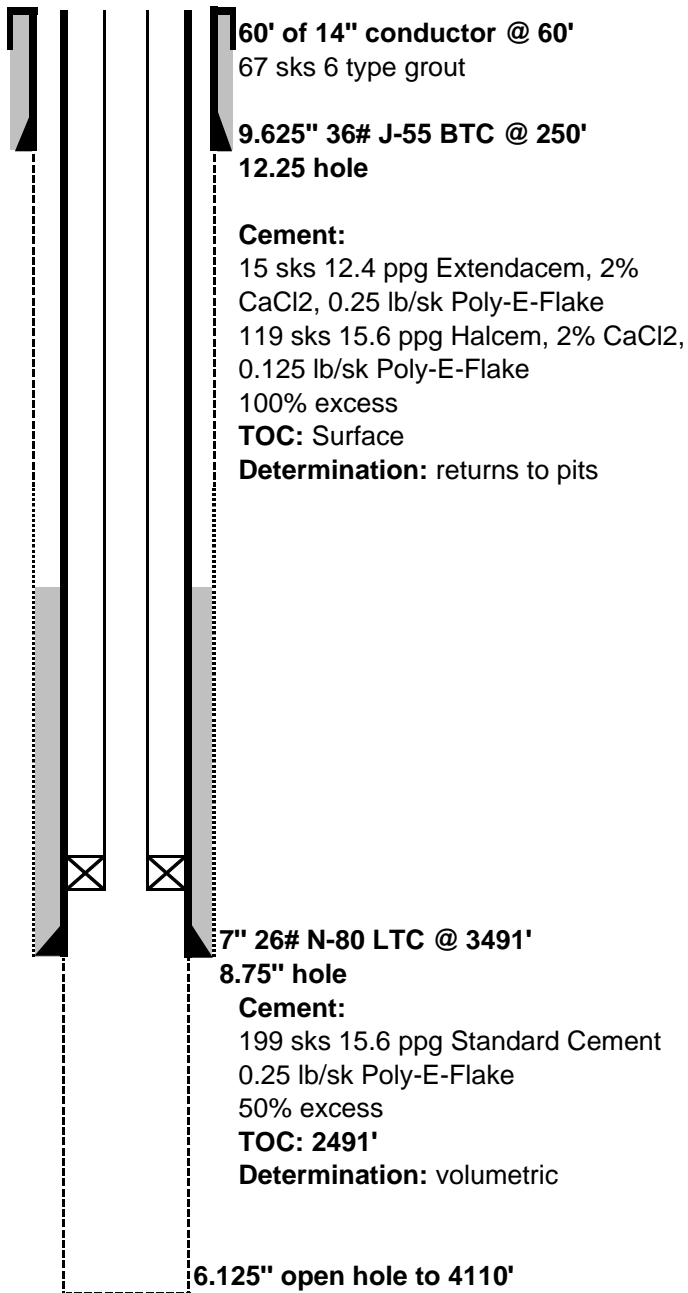

Packer Type: Baker Hornet
Tubing Size: 4.5" 11.6# IPC
Length: 3416'
Annular Fluid: 5 gal/ 100 gal Baker C335P
w/ Oxy Scav

Arbuckle: @ 3441'

Granite: @ 4080'

memo



To: Sharon Cook

cc:

From: Aaron Tenenholz

Subject: Nattier 16H-2 Lease Acreage Summary, 24S-2E, Harvey County, KS

Sharon,

There is one (1) lease in which Encana Oil & Gas (USA) Inc. is the current lessee that covers 320 acres within the planned unit boundary of the above referenced well.

The proposed unit will be the East Half of Section 16, T24S-R2E in Harvey County, Kansas and will be a total of 320 acres.

The lease is within its primary term and the lessor is Lois A. Nattier, Trustee of the Lois A. Nattier Trust.

Due to the fact that one (1) lease covers the proposed unit there will be no need to pool any acreage.

If you need any further info just let me know.

Thanks,

A handwritten signature in black ink, appearing to read "A. Tenenholz".

Aaron Tenenholz
Land Negotiator
Encana Oil & Gas (USA) Inc.

Encana Oil & Gas (USA) Inc.
14001 N. Dallas Pkwy, Suite 1100
Dallas, Texas
United States 75240
t 469.461.2346
www.encana.com

**NOTICE TO OPERATORS FILING INTENT TO DRILL
FOR DISPOSAL OR ENHANCED RECOVERY
INJECTION WELLS, (CLASS II INJECTION WELL)**

The attached approved Notice of Intent to Drill indicates the proposed well is to be used for injection. An approved "Intent to Drill" does not approve injection authority as a Class II Injection Well in Kansas.

Before any well is used for injection purposes, the operator must file an application for injection authority in accordance with K.A.R. 82-3-401 and provide notice in accordance with K.A.R. 82-3-402. The Conservation Division must issue a written permit granting the application before commencement of injection.

The Conservation Division requirements and restrictions associated with Class II Injection are identified in K.A.R. 82-3-400 et seq of our regulations. Associated regulations governing drilling, completion and injection applications may be found in K.A.R. 82-3-135, Table I, Table II, in the Cedar Hills Sandstone Moratorium, (Docket #156,397-C), and the Eastern Kansas Surface Casing Order, (Docket #133,891-C).

If you have questions regarding the approval of injection authority, an injection application may be filed as a "Design Approval" before actual drilling and completion of the well occurs. If you have any questions or concerns regarding Class II injection wells or regulations, call the Underground Injection Control Department at 316-337-6200.

Failure to obtain commission approval before beginning injection is punishable by a penalty, shut-in of the well or both.