

Well location, YOUNG TRUST 2309 #35-1H, located as shown in the SE 1/4 SE 1/4 of Section 35, T23S, R9W, 6th P.M., Reno County, Kansas.

BASIS OF ELEVATION

SPOT ELEVATION LOCATED AT THE SOUTHWEST CORNER OF SECTION 18, T23S, R8W, 6th P.M. TAKEN FROM THE ALDEN SE, QUADRANGLE, KANSAS, RENO COUNTY, 7.5 MINUTE QUAD (TOPOGRAPHIC MAP) PUBLISHED BY THE UNITED STATES DEPARTMENT OF THE INTERIOR, GEOLOGICAL SURVEY, SAID ELEVATION IS MARKED AS BEING 1688 FEET.

BASIS OF BEARINGS

BASIS OF BEARINGS IS A G.P.S. OBSERVATION.

Limestone, Rebar  
0.5' Below Ground  
In Road  
NAD 27 Kansas South  
N: 490567.36  
E: 2060875.91

Limestone, Rebar  
0.5' Below Ground,  
In Road  
NAD 27 Kansas South  
N: 490577.92  
E: 2066196.44

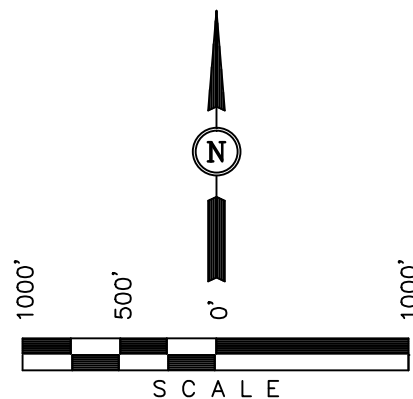
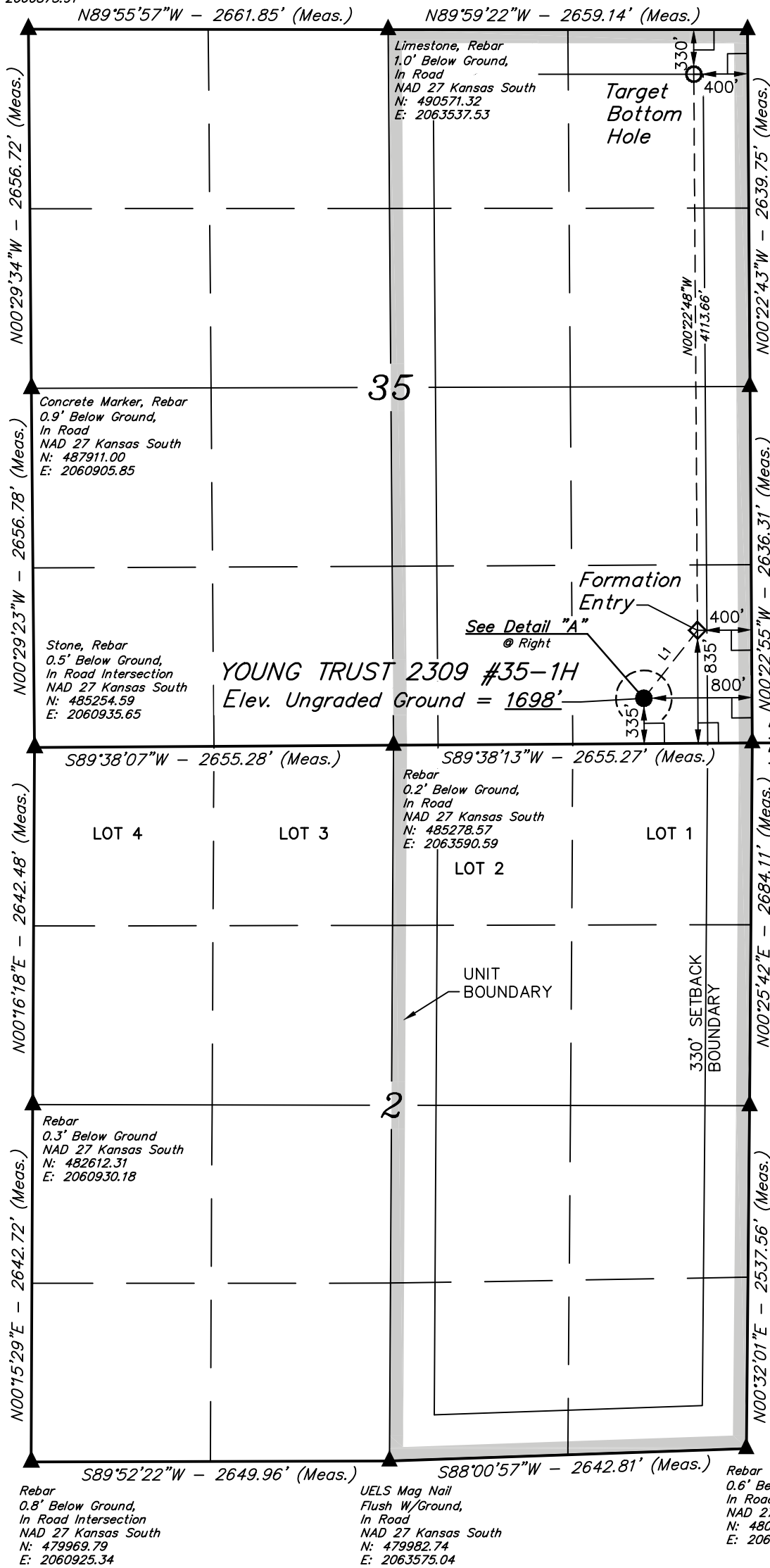

LINE TABLE		
LINE	DIRECTION	LENGTH
L1	N38°16'36"E	640.13'

LEGEND:

- └─┘ = 90° SYMBOL
- = PROPOSED WELL HEAD.
- ▲ = SECTION CORNERS LOCATED.

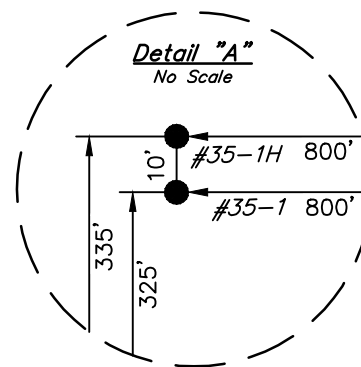

CERTIFICATE

THIS IS TO CERTIFY THAT THE ABOVE PLAT WAS PREPARED FROM FIELD NOTES OF ACTUAL SURVEYS MADE BY ME OR UNDER MY SUPERVISION AND THAT THE SAME ARE TRUE AND CORRECT TO THE BEST OF MY KNOWLEDGE AND BELIEF.

REGISTERED LAND SURVEYOR  
REGISTRATION NO. 1451  
STATE OF UTAH

UINTAH ENGINEERING & LAND SURVEYING  
85 SOUTH 200 EAST - VERNAL, UTAH 84078  
(435) 789-1017

NAD 83 (#35-1H TARGET BOTTOM HOLE)	NAD 83 (#35-1H FORMATION ENTRY)	NAD 83 (#35-1H SURFACE LOCATION)	SCALE	DATE SURVEYED:	DATE DRAWN:
LATITUDE = 38°00'46.31" (38.012864) LONGITUDE = 98°16'19.03" (98.271953)	LATITUDE = 38°00'05.65" (38.001569) LONGITUDE = 98°16'18.68" (98.271856)	LATITUDE = 38°00'00.68" (38.000189) LONGITUDE = 98°16'23.64" (98.273233)	1" = 1000'	10-16-12	10-23-12
NAD 27 (#35-1H TARGET BOTTOM HOLE)	NAD 27 (#35-1H FORMATION ENTRY)	NAD 27 (#35-1H SURFACE LOCATION)	PARTY	REFERENCES	
LATITUDE = 38°00'46.27" (38.012853) LONGITUDE = 98°16'17.80" (98.271611)	LATITUDE = 38°00'05.60" (38.001556) LONGITUDE = 98°16'17.45" (98.271514)	LATITUDE = 38°00'00.63" (38.000175) LONGITUDE = 98°16'22.40" (98.272889)	B.L. T.B. C.A.G.	G.L.O. PLAT	
STATE PLANE NAD 27 (KANSAS SOUTH) N: 490246.96 E: 2065799.52	STATE PLANE NAD 27 (KANSAS SOUTH) N: 486133.78 E: 2065837.78	STATE PLANE NAD 27 (KANSAS SOUTH) N: 485630.24 E: 2065442.62	WEATHER	FILE	
			WARM	SGOMI	