

Well location, HEDRICK 2106 #19-1H, located as shown in the SE 1/4 NE 1/4 of Section 19, T21S, R6W, 6th P.M., Rice County, Kansas.

BASIS OF ELEVATION

SPOT ELEVATION LOCATED AT THE SW CORNER OF SECTION 18, T23S, R8W, 6th P.M. TAKEN FROM THE ALDEN SE, QUADRANGLE, KANSAS, RENO COUNTY, 7.5 MINUTE QUAD (TOPOGRAPHIC MAP) PUBLISHED BY THE UNITED STATES DEPARTMENT OF THE INTERIOR, GEOLOGICAL SURVEY, SAID ELEVATION IS MARKED AS BEING 1688 FEET.

BASIS OF BEARINGS

BASIS OF BEARINGS IS A G.P.S. OBSERVATION.

Limestone, Rebar
0.5' Below Ground,
In Road
NAD 27 Kansas South
N: 570190.65
E: 2134418.08

Limestone, Rebar
0.9' Below Ground
NAD 27 Kansas South
N: 570219.60
E: 2136941.21

2 Sandstones, UELS
Alum. Cap 0.3' Below
Ground
NAD 27 Kansas South
N: 570222.33
E: 2139569.42

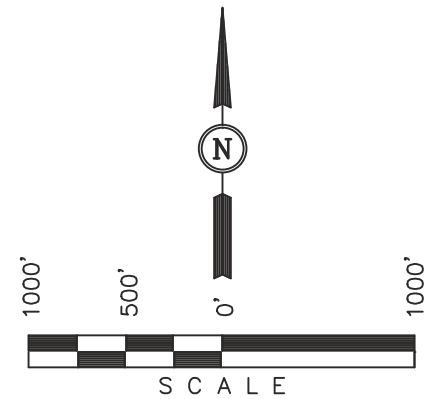
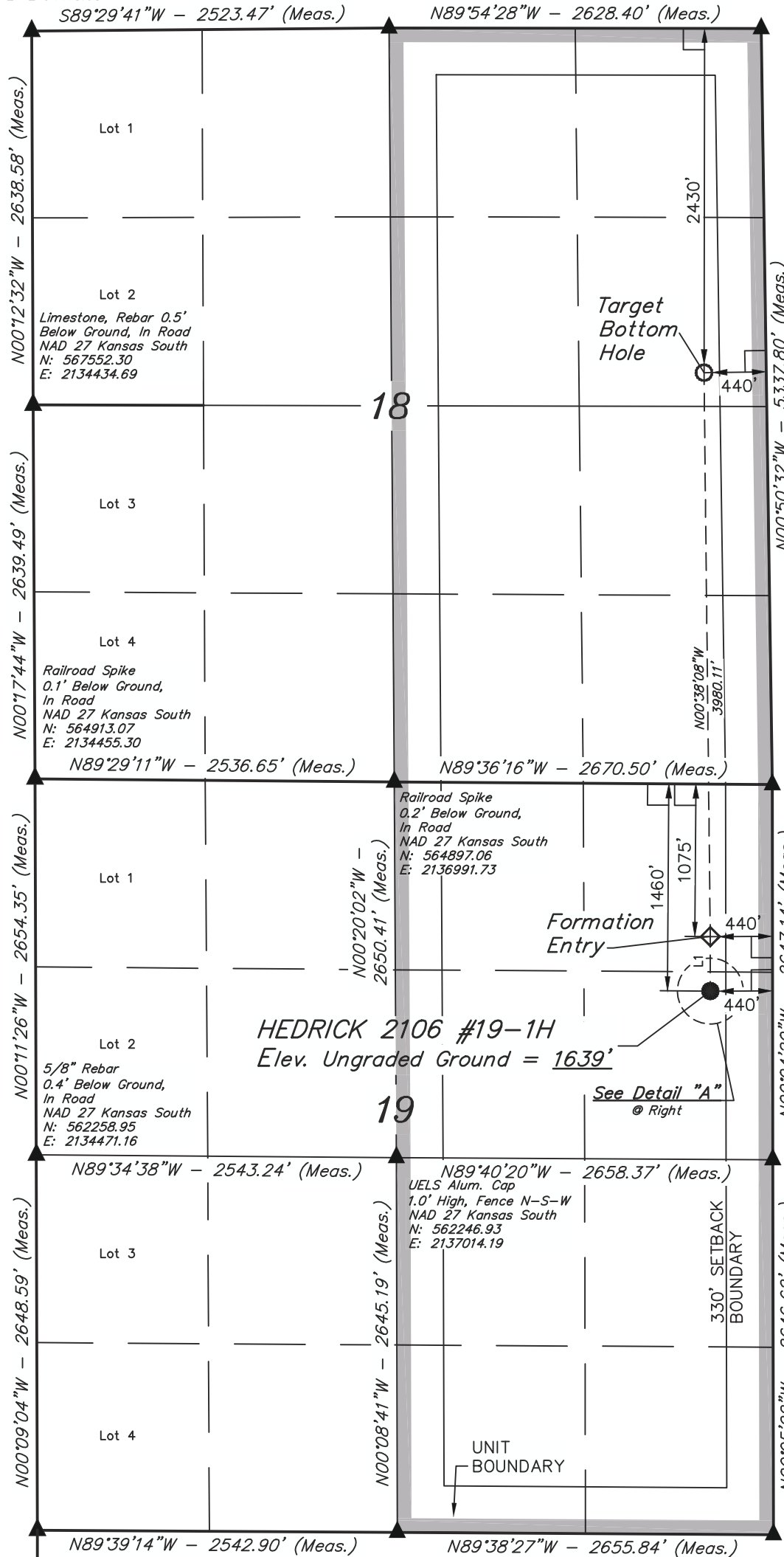

LINE TABLE		
LINE	DIRECTION	LENGTH
L1	N00°03'54"W	385.09'

LEGEND:

- └─┘ = 90° SYMBOL
- = PROPOSED WELL HEAD.
- ▲ = SECTION CORNERS LOCATED.

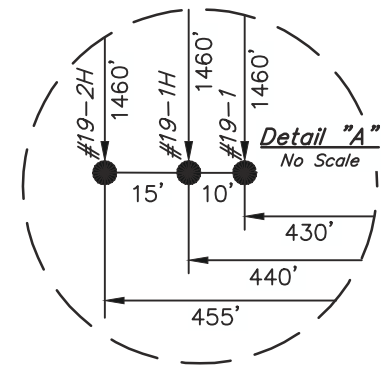

R 7 W 5/8" Rebar
1.1' Below Ground,
In Road
NAD 27 Kansas South
N: 559610.58
E: 2134485.17

Limestone, Rebar
0.8' Below Ground,
In Road
NAD 27 Kansas South
N: 559601.96
E: 2137027.88

Limestone, Rebar
1.0' Below Ground,
In Road
NAD 27 Kansas South
N: 559592.36
E: 2139683.50

CERTIFICATE

THIS IS TO CERTIFY THAT THE ABOVE PLAT WAS PREPARED FROM FIELD NOTES OF ACTUAL SURVEYS MADE BY ME OR UNDER MY SUPERVISION AND THAT THE SAME ARE TRUE AND CORRECT TO THE BEST OF MY KNOWLEDGE AND BELIEF.

REGISTERED LAND SURVEYOR
REGISTRATION NO. 1458
STATE OF KANSAS

REVISED: 11-16-12

UINTAH ENGINEERING & LAND SURVEYING
85 SOUTH 200 EAST - VERNAL, UTAH 84078
(435) 789-1017

NAD 83 (#19-1H TARGET BOTTOM HOLE) LATITUDE = 38°13'30.16" (38.225044) LONGITUDE = 98°00'57.14" (98.015872)	NAD 83 (#19-1H FORMATION ENTRY) LATITUDE = 38°12'50.82" (38.214117) LONGITUDE = 98°00'56.72" (98.015756)	NAD 83 (#19-1H SURFACE LOCATION) LATITUDE = 38°12'47.01" (38.213058) LONGITUDE = 98°00'56.72" (98.015756)	SCALE 1" = 1000'	DATE SURVEYED: 08-15-12	DATE DRAWN: 09-11-12
NAD 27 (#19-1H TARGET BOTTOM HOLE) LATITUDE = 38°13'30.12" (38.225033) LONGITUDE = 98°00'55.95" (98.015542)	NAD 27 (#19-1H FORMATION ENTRY) LATITUDE = 38°12'50.78" (38.214106) LONGITUDE = 98°00'55.52" (98.015422)	NAD 27 (#19-1H SURFACE LOCATION) LATITUDE = 38°12'46.97" (38.213047) LONGITUDE = 98°00'55.53" (98.015425)	PARTY J.P. C.B. C.A.G.	REFERENCES G.L.O. PLAT	
STATE PLANE NAD 27 (KANSAS SOUTH) N: 567792.08 E: 2139171.55	STATE PLANE NAD 27 (KANSAS SOUTH) N: 563812.62 E: 2139226.23	STATE PLANE NAD 27 (KANSAS SOUTH) N: 563427.56 E: 2139227.69	WEATHER HOT	FILE SGOMI	