



KANSAS CORPORATION COMMISSION 1120976
OIL & GAS CONSERVATION DIVISION

Form must be Typed
Form must be Signed
All blanks must be Filled

For KCC Use:
Effective Date:
District #
SGA? Yes No

NOTICE OF INTENT TO DRILL

Must be approved by KCC five (5) days prior to commencing well

Form KSONA-1, Certification of Compliance with the Kansas Surface Owner Notification Act, MUST be submitted with this form.

Expected Spud Date: month day year

Spot Description:

OPERATOR: License#
Name:
Address 1:
Address 2:
City: State: Zip:
Contact Person:
Phone:

Sec. Twp. S. R. E W
feet from N / S Line of Section
feet from E / W Line of Section

Is SECTION: Regular Irregular?

(Note: Locate well on the Section Plat on reverse side)

CONTRACTOR: License#
Name:

County:

Lease Name: Well #:

Field Name:

Is this a Prorated / Spaced Field? Yes No

Target Formation(s):

Nearest Lease or unit boundary line (in footage):

Ground Surface Elevation: feet MSL

Water well within one-quarter mile: Yes No

Public water supply well within one mile: Yes No

Depth to bottom of fresh water:

Depth to bottom of usable water:

Surface Pipe by Alternate: I II

Length of Surface Pipe Planned to be set:

Length of Conductor Pipe (if any):

Projected Total Depth:

Formation at Total Depth:

Water Source for Drilling Operations:

Well Farm Pond Other:

DWR Permit #: (Note: Apply for Permit with DWR)

Will Cores be taken? Yes No

If Yes, proposed zone:

AFFIDAVIT

The undersigned hereby affirms that the drilling, completion and eventual plugging of this well will comply with K.S.A. 55 et. seq.

It is agreed that the following minimum requirements will be met:

- 1. Notify the appropriate district office prior to spudding of well;
2. A copy of the approved notice of intent to drill shall be posted on each drilling rig;
3. The minimum amount of surface pipe as specified below shall be set by circulating cement to the top; in all cases surface pipe shall be set through all unconsolidated materials plus a minimum of 20 feet into the underlying formation.
4. If the well is dry hole, an agreement between the operator and the district office on plug length and placement is necessary prior to plugging;
5. The appropriate district office will be notified before well is either plugged or production casing is cemented in;
6. If an ALTERNATE II COMPLETION, production pipe shall be cemented from below any usable water to surface within 120 DAYS of spud date. Or pursuant to Appendix "B" - Eastern Kansas surface casing order #133,891-C, which applies to the KCC District 3 area, alternate II cementing must be completed within 30 days of the spud date or the well shall be plugged. In all cases, NOTIFY district office prior to any cementing.

Submitted Electronically

For KCC Use ONLY
API # 15 -
Conductor pipe required feet
Minimum surface pipe required feet per ALT. I II
Approved by:
This authorization expires:
(This authorization void if drilling not started within 12 months of approval date.)
Spud date: Agent:

Remember to:

- File Certification of Compliance with the Kansas Surface Owner Notification Act (KSONA-1) with Intent to Drill;
- File Drill Pit Application (form CDP-1) with Intent to Drill;
- File Completion Form ACO-1 within 120 days of spud date;
- File acreage attribution plat according to field proration orders;
- Notify appropriate district office 48 hours prior to workover or re-entry;
- Submit plugging report (CP-4) after plugging is completed (within 60 days);
- Obtain written approval before disposing or injecting salt water.
- If well will not be drilled or permit has expired (See: authorized expiration date) please check the box below and return to the address below.

Well will not be drilled or Permit Expired Date:

Signature of Operator or Agent:

For KCC Use ONLY

API # 15 - _____

IN ALL CASES PLOT THE INTENDED WELL ON THE PLAT BELOW

In all cases, please fully complete this side of the form. Include items 1 through 5 at the bottom of this page.

Operator: _____

Lease: _____

Well Number: _____

Field: _____

Number of Acres attributable to well: _____

QTR/QTR/QTR/QTR of acreage: _____ - _____ - _____ - _____

Location of Well: County: _____

_____ feet from N / S Line of Section

_____ feet from E / W Line of Section

Sec. _____ Twp. _____ S. R. _____ E W

Is Section: Regular or Irregular

If Section is Irregular, locate well from nearest corner boundary.

Section corner used: NE NW SE SW

PLAT

Show location of the well. Show footage to the nearest lease or unit boundary line. Show the predicted locations of lease roads, tank batteries, pipelines and electrical lines, as required by the Kansas Surface Owner Notice Act (House Bill 2032). You may attach a separate plat if desired.

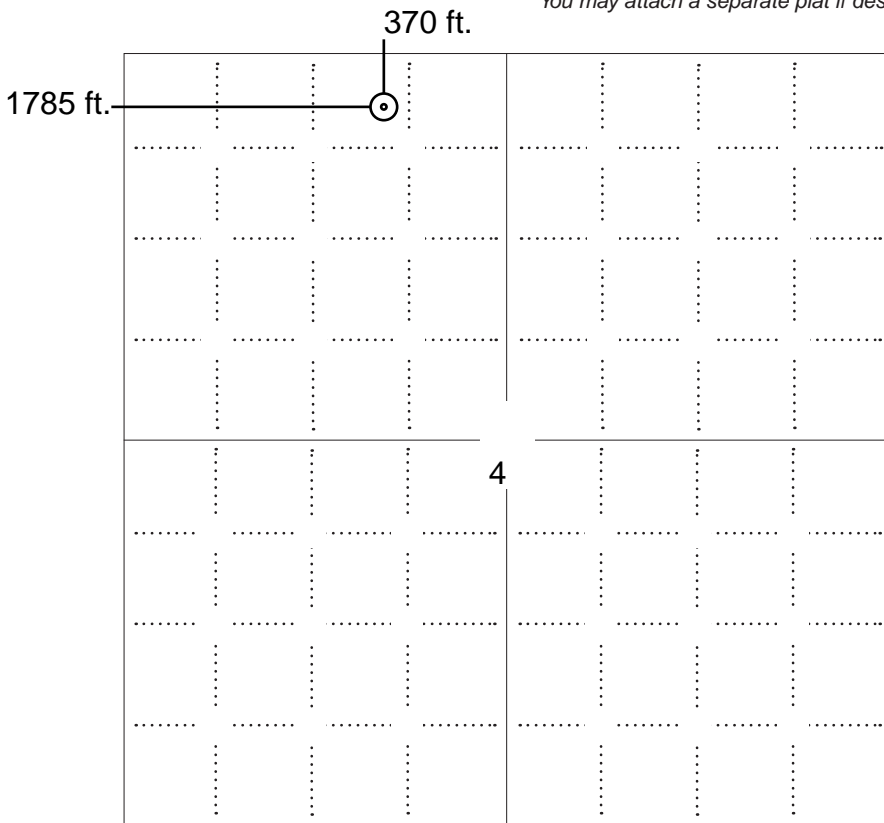

LEGEND

- Well Location
- Tank Battery Location
- Pipeline Location
- Electric Line Location
- Lease Road Location



NOTE: In all cases locate the spot of the proposed drilling locaton.

In plotting the proposed location of the well, you must show:

1. The manner in which you are using the depicted plat by identifying section lines, i.e. 1 section, 1 section with 8 surrounding sections, 4 sections, etc.
2. The distance of the proposed drilling location from the south / north and east / west outside section lines.
3. The distance to the nearest lease or unit boundary line (in footage).
4. If proposed location is located within a prorated or spaced field a certificate of acreage attribution plat must be attached: (C0-7 for oil wells; CG-8 for gas wells).
5. The predicted locations of lease roads, tank batteries, pipelines, and electrical lines.

**APPLICATION FOR SURFACE PIT***Submit in Duplicate*

Operator Name:		License Number:	
Operator Address:			
Contact Person:		Phone Number:	
Lease Name & Well No.:		Pit Location (QQQQ): ____ - ____ - ____ - ____	
Type of Pit: <input type="checkbox"/> Emergency Pit <input type="checkbox"/> Burn Pit <input type="checkbox"/> Settling Pit <input type="checkbox"/> Drilling Pit <input type="checkbox"/> Workover Pit <input type="checkbox"/> Haul-Off Pit <i>(If WP Supply API No. or Year Drilled)</i>		Pit is: <input type="checkbox"/> Proposed <input type="checkbox"/> Existing If Existing, date constructed: _____ Pit capacity: _____ (bbls)	
Is the pit located in a Sensitive Ground Water Area? <input type="checkbox"/> Yes <input type="checkbox"/> No		Chloride concentration: _____ mg/l <i>(For Emergency Pits and Settling Pits only)</i>	
Is the bottom below ground level? <input type="checkbox"/> Yes <input type="checkbox"/> No		Artificial Liner? <input type="checkbox"/> Yes <input type="checkbox"/> No	
How is the pit lined if a plastic liner is not used?			
Pit dimensions (all but working pits): _____ Length (feet) _____ Width (feet) <input type="checkbox"/> N/A: Steel Pits Depth from ground level to deepest point: _____ (feet) <input type="checkbox"/> No Pit			
If the pit is lined give a brief description of the liner material, thickness and installation procedure.		Describe procedures for periodic maintenance and determining liner integrity, including any special monitoring.	
Distance to nearest water well within one-mile of pit: _____ feet Depth of water well _____ feet		Depth to shallowest fresh water _____ feet. Source of information: <input type="checkbox"/> measured <input type="checkbox"/> well owner <input type="checkbox"/> electric log <input type="checkbox"/> KDWR	
Emergency, Settling and Burn Pits ONLY: Producing Formation: _____ Number of producing wells on lease: _____ Barrels of fluid produced daily: _____ Does the slope from the tank battery allow all spilled fluids to flow into the pit? <input type="checkbox"/> Yes <input type="checkbox"/> No		Drilling, Workover and Haul-Off Pits ONLY: Type of material utilized in drilling/workover: _____ Number of working pits to be utilized: _____ Abandonment procedure: _____ _____ Drill pits must be closed within 365 days of spud date.	
Submitted Electronically			

KCC OFFICE USE ONLY
 Liner Steel Pit RFAC RFAS

 Date Received: _____ Permit Number: _____ Permit Date: _____ Lease Inspection: Yes No

**CERTIFICATION OF COMPLIANCE WITH THE
KANSAS SURFACE OWNER NOTIFICATION ACT**

This form must be submitted with all Forms C-1 (Notice of Intent to Drill); CB-1 (Cathodic Protection Borehole Intent); T-1 (Request for Change of Operator Transfer of Injection or Surface Pit Permit); and CP-1 (Well Plugging Application). Any such form submitted without an accompanying Form KSONA-1 will be returned.

Select the corresponding form being filed: C-1 (Intent) CB-1 (Cathodic Protection Borehole Intent) T-1 (Transfer) CP-1 (Plugging Application)

OPERATOR: License # _____

Name: _____

Address 1: _____

Address 2: _____

City: _____ State: _____ Zip: _____ + _____

Contact Person: _____

Phone: (_____) _____ Fax: (_____) _____

Email Address: _____

Well Location:

____ - ____ - ____ - ____ Sec. ____ Twp. ____ S. R. ____ East West

County: _____

Lease Name: _____ Well #: _____

If filing a Form T-1 for multiple wells on a lease, enter the legal description of the lease below:

Surface Owner Information:

Name: _____

Address 1: _____

Address 2: _____

City: _____ State: _____ Zip: _____ + _____

When filing a Form T-1 involving multiple surface owners, attach an additional sheet listing all of the information to the left for each surface owner. Surface owner information can be found in the records of the register of deeds for the county, and in the real estate property tax records of the county treasurer.

If this form is being submitted with a Form C-1 (Intent) or CB-1 (Cathodic Protection Borehole Intent), you must supply the surface owners and the KCC with a plat showing the predicted locations of lease roads, tank batteries, pipelines, and electrical lines. The locations shown on the plat are preliminary non-binding estimates. The locations may be entered on the Form C-1 plat, Form CB-1 plat, or a separate plat may be submitted.

Select one of the following:

I certify that, pursuant to the Kansas Surface Owner Notice Act (House Bill 2032), I have provided the following to the surface owner(s) of the land upon which the subject well is or will be located: 1) a copy of the Form C-1, Form CB-1, Form T-1, or Form CP-1 that I am filing in connection with this form; 2) if the form being filed is a Form C-1 or Form CB-1, the plat(s) required by this form; and 3) my operator name, address, phone number, fax, and email address.

I have not provided this information to the surface owner(s). I acknowledge that, because I have not provided this information, the KCC will be required to send this information to the surface owner(s). To mitigate the additional cost of the KCC performing this task, I acknowledge that I am being charged a \$30.00 handling fee, payable to the KCC, which is enclosed with this form.

If choosing the second option, submit payment of the \$30.00 handling fee with this form. If the fee is not received with this form, the KSONA-1 form and the associated Form C-1, Form CB-1, Form T-1, or Form CP-1 will be returned.

I Submitted Electronically

Well location, REFFNER 2308 #4-1HN, located as shown in the Lot 3 of Section 4, T23S, R8W, 6th P.M., Reno County, Kansas.

BASIS OF ELEVATION

SPOT ELEVATION LOCATED AT THE SW CORNER OF SECTION 18, T23S, R8W, 6th P.M. TAKEN FROM THE ALDEN SE, QUADRANGLE, KANSAS, RENO COUNTY, 7.5 MINUTE QUAD (TOPOGRAPHIC MAP) PUBLISHED BY THE UNITED STATES DEPARTMENT OF THE INTERIOR, GEOLOGICAL SURVEY, SAID ELEVATION IS MARKED AS BEING 1688 FEET.

BASIS OF BEARINGS

BASIS OF BEARINGS IS A G.P.S. OBSERVATION.

1/2" Rebar
0.5' Below Ground,
In Road
NAD 27 Kansas South
N: 522216.78
E: 2081869.88

Large Spike
0.3' Below Ground
NAD 27 Kansas South
N: 522283.84
E: 2084519.92

5/8" Rebar
0.3' Below Ground,
In Road
NAD 27 Kansas South
N: 522333.50
E: 2087162.09

5/8" Rebar
0.5' Below Ground,
In Road
NAD 27 Kansas South
N: 521014.35
E: 2087167.76

5/8" Rebar
0.2' Below Ground
NAD 27 Kansas South
N: 519716.42
E: 2087165.85

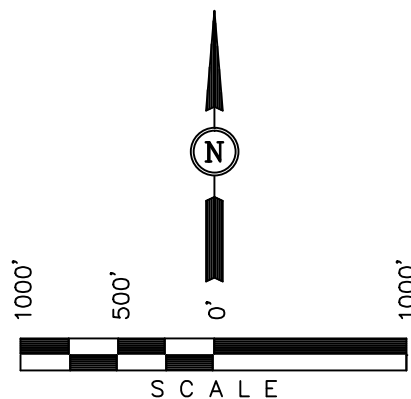

LEGEND:

- └─┘ = 90° SYMBOL
- = PROPOSED WELL HEAD.
- ▲ = SECTION CORNERS LOCATED.

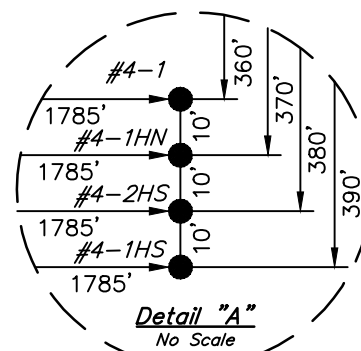

LINE TABLE		
LINE	DIRECTION	LENGTH
L1	N17°24'33"W	453.16'

REFNER 2308 #4-1HN
Elev. Ungraded Ground = 1659'

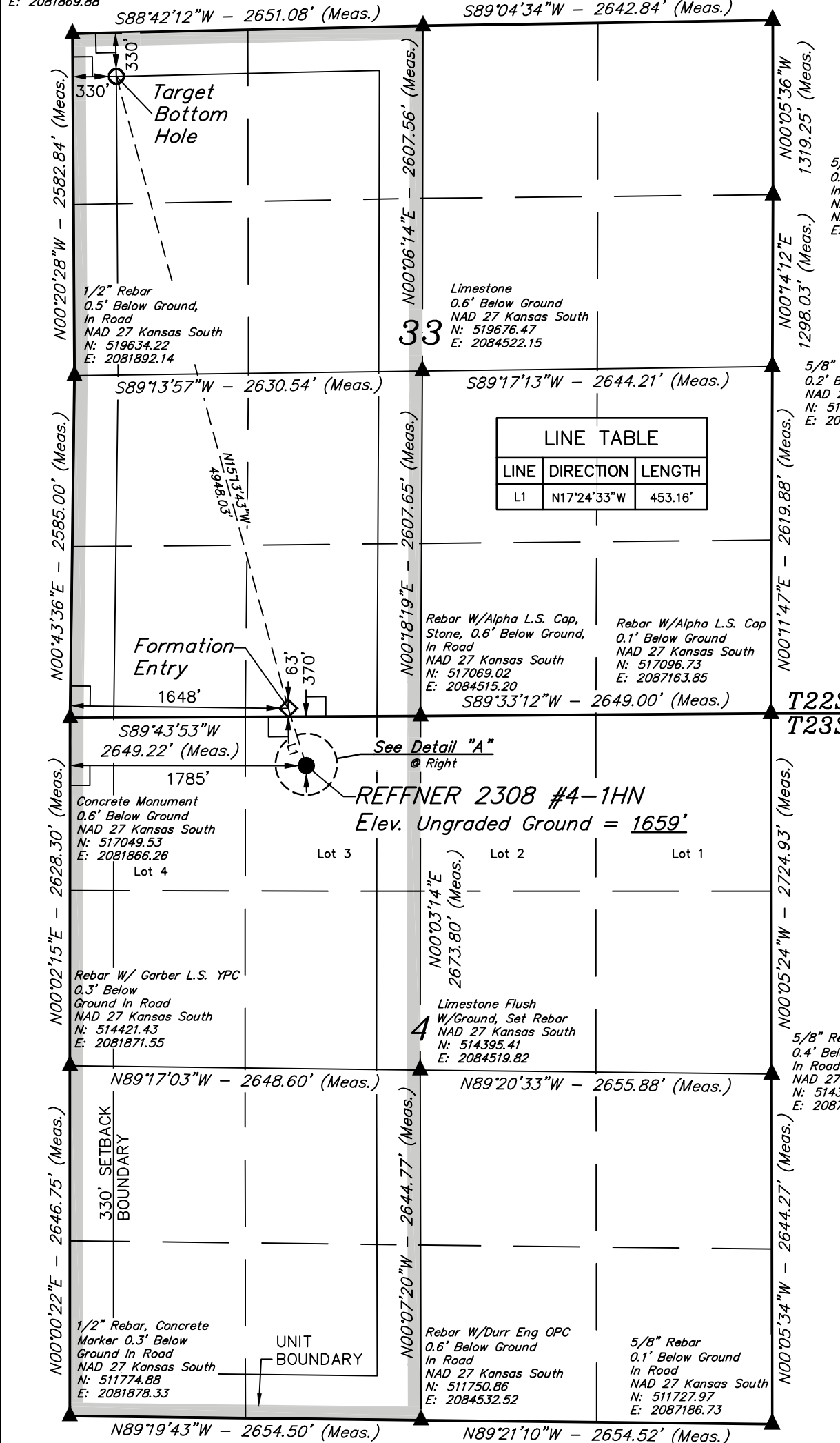

CERTIFICATE

THIS IS TO CERTIFY THAT THE ABOVE PLAT WAS PREPARED FROM FIELD NOTES OF ACTUAL SURVEYS MADE BY ME OR UNDER MY SUPERVISION AND THAT THE SAME ARE TRUE AND CORRECT TO THE BEST OF MY KNOWLEDGE AND BELIEF.

Robert Justin Pearce

REGISTERED LAND SURVEYOR
REGISTRATION NO. 1451

REVISED: 03-04-13 C.C.
REVISED: 02-21-13

STATE OF KANSAS 03-04-13

UINTAH ENGINEERING & LAND SURVEYING
85 SOUTH 200 EAST - VERNAL, UTAH 84078
(435) 789-1017

NAD 83 (#4-1HN TARGET BOTTOM HOLE) LATITUDE = 38°05'58.75" (38.099653) LONGITUDE = 98°12'52.85" (98.214681)	NAD 83 (#4-1HN FORMATION ENTRY) LATITUDE = 38°05'11.55" (38.086542) LONGITUDE = 98°12'36.61" (98.210169)	NAD 83 (#4-1HN SURFACE LOCATION) LATITUDE = 38°05'07.27" (38.085353) LONGITUDE = 98°12'34.92" (98.209700)	SCALE 1" = 1000'	DATE SURVEYED: 11-28-12	DATE DRAWN: 11-30-12
NAD 27 (#4-1HN TARGET BOTTOM HOLE) LATITUDE = 38°05'58.71" (38.099642) LONGITUDE = 98°12'51.62" (98.214339)	NAD 27 (#4-1HN FORMATION ENTRY) LATITUDE = 38°05'11.50" (38.086528) LONGITUDE = 98°12'35.39" (98.209831)	NAD 27 (#4-1HN SURFACE LOCATION) LATITUDE = 38°05'07.23" (38.085342) LONGITUDE = 98°12'33.70" (98.209361)	PARTY C.B. D.W. C.A.G.	REFERENCES G.L.O. PLAT	
STATE PLANE NAD 27 (KANSAS SOUTH) N: 521895.12 E: 2082202.64	STATE PLANE NAD 27 (KANSAS SOUTH) N: 517124.66 E: 2083514.97	STATE PLANE NAD 27 (KANSAS SOUTH) N: 516692.65 E: 2083651.69	WEATHER COOL	FILE SGOMI	

Conservation Division
Finney State Office Building
130 S. Market, Rm. 2078
Wichita, KS 67202-3802



Phone: 316-337-6200
Fax: 316-337-6211
<http://kcc.ks.gov/>

Mark Sievers, Chairman
Thomas E. Wright, Commissioner
Shari Feist Albrecht, Commissioner

Sam Brownback, Governor

March 06, 2013

Damonica Pierson
Shell Gulf of Mexico Inc.
150 N DAIRY-ASHFORD (77079)
PO BOX 576 (77001-0576)
HOUSTON, TX 77001-0576

Re: Drilling Pit Application
API 15-155-21629-01-00
Reffner 2308 4-1HN
NW/4 Sec.04-23S-08W
Reno County, Kansas

Dear Damonica Pierson:

According to the drilling pit application referenced above, this pit is to be used for fresh water only. A closed loop system is to be utilized.

If you have any questions or concerns please feel free to contact the District Office at (316) 630-4000.

Summary of Changes

Lease Name and Number: Reffner 2308 4-1HN

API/Permit #: 15-155-21629-01-00

Doc ID: 1120976

Correction Number: 1

Approved By: Rick Hestermann 03/06/2013

Field Name	Previous Value	New Value
Feet to Nearest Water Well Within One-Mile of Pit	989	975
KCC Only - Approved By	Rick Hestermann 01/18/2013	Rick Hestermann 03/06/2013
KCC Only - Approved Date	01/18/2013	03/06/2013
KCC Only - CDP1 Steel Pit	Yes	No
KCC Only - Date Received	01/10/2013	03/04/2013
Liner		Yes
LocationInfoLink	https://solar.kgs.ku.edu/kcc/detail/locationInformation.cfm?section=4&to390	https://solar.kgs.ku.edu/kcc/detail/locationInformation.cfm?section=4&to370
Number of Feet North or South From Section Line	390	370
Number of Feet North or South From Section Line	390	370
Save Link	../kcc/detail/operatorEditDetail.cfm?docID=1104636	../kcc/detail/operatorEditDetail.cfm?docID=1120976

Summary of Attachments

Lease Name and Number: Reffner 2308 4-1HN

API: 15-155-21629-01-00

Doc ID: 1120976

Correction Number: 1

Approved By: Rick Hestermann 03/06/2013

Attachment Name

Reffner 2308 4-1HN LEGAL PLAT rev

No Earthen Pits