

For KCC Use ONLY

API # 15 - _____

IN ALL CASES PLOT THE INTENDED WELL ON THE PLAT BELOW

In all cases, please fully complete this side of the form. Include items 1 through 5 at the bottom of this page.

Operator: W & W Production Company, General Partnership
 Lease: Harner
 Well Number: W-21
 Field: Humboldt-Chanute
 Number of Acres attributable to well: _____
 QTR/QTR/QTR/QTR of acreage: NW - SW - NE - NW

Location of Well: County: Allen
 675 feet from N / S Line of Section
 1620 feet from E / W Line of Section
 Sec. 23 Twp. 26 S. R. 18 E W
 Is Section: Regular or Irregular
 If Section is Irregular, locate well from nearest corner boundary.
 Section corner used: NE NW SE SW

Show location of the well. Show footage to the nearest lease or unit boundary line. Show the predicted locations of lease roads, tank batteries, pipelines and electrical lines, as required by the Kansas Surface Owner Notice Act (House Bill 2032). You may attach a separate plat if desired.

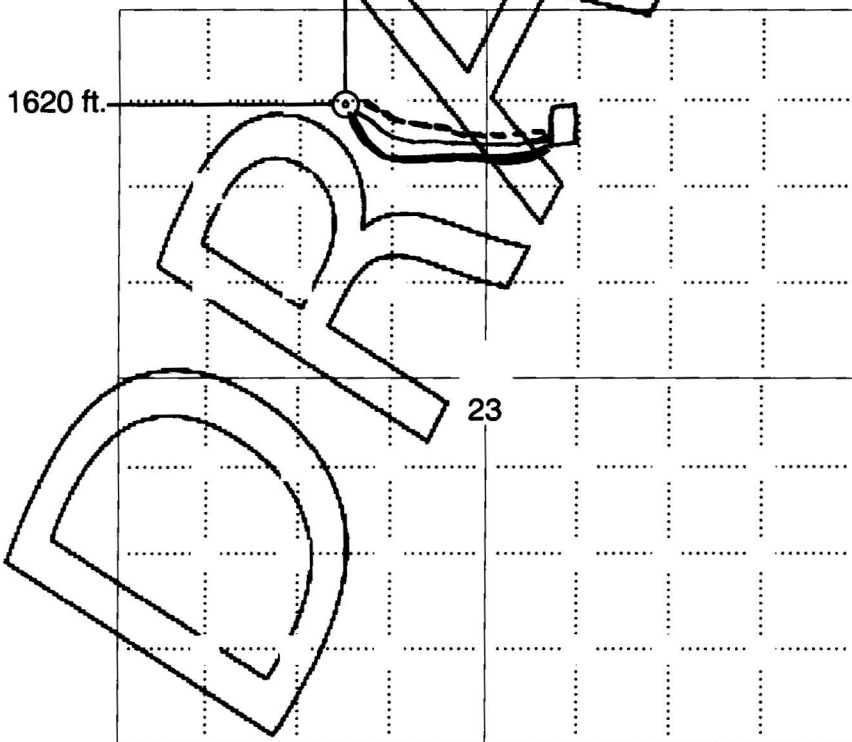

LEGEND

- Well Location
- Tank Battery Location
- Pipeline Location
- Electric Line Location
- Lease Road Location

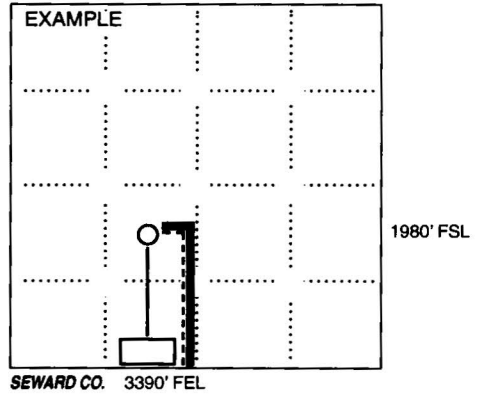

NOTE: In all cases locate the spot of the proposed drilling locaton.

In plotting the proposed location of the well, you must show:

1. The manner in which you are using the depicted plat by identifying section lines, i.e. 1 section, 1 section with 8 surrounding sections, 4 sections, etc.
2. The distance of the proposed drilling location from the south / north and east / west outside section lines.
3. The distance to the nearest lease or unit boundary line (in footage).
4. If proposed location is located within a prorated or spaced field a certificate of acreage attribution plat must be attached: (CO-7 for oil wells; CG-8 for gas wells).
5. The predicted locations of lease roads, tank batteries, pipelines, and electrical lines.