

For KCC Use ONLY

API # 15 - _____

IN ALL CASES PLOT THE INTENDED WELL ON THE PLAT BELOW

In all cases, please fully complete this side of the form. Include items 1 through 5 at the bottom of this page.

Operator: _____
 Lease: _____
 Well Number: _____
 Field: _____
 Number of Acres attributable to well: _____
 QTR/QTR/QTR/QTR of acreage: _____ - _____ - _____ - _____

Location of Well: County: _____
 _____ feet from N / S Line of Section
 _____ feet from E / W Line of Section
 Sec. _____ Twp. _____ S. R. _____ E W

Is Section: Regular or Irregular

If Section is Irregular, locate well from nearest corner boundary.

Section corner used: NE NW SE SW

PLAT

Show location of the well. Show footage to the nearest lease or unit boundary line. Show the predicted locations of lease roads, tank batteries, pipelines and electrical lines, as required by the Kansas Surface Owner Notice Act (House Bill 2032). You may attach a separate plat if desired.

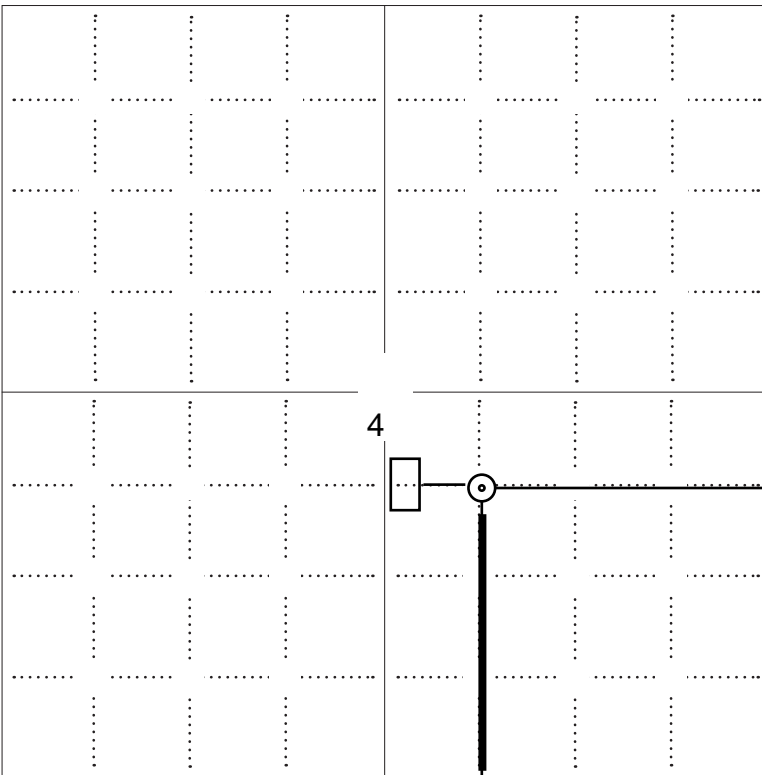

LEGEND

- Well Location
- Tank Battery Location
- Pipeline Location
- Electric Line Location
- Lease Road Location

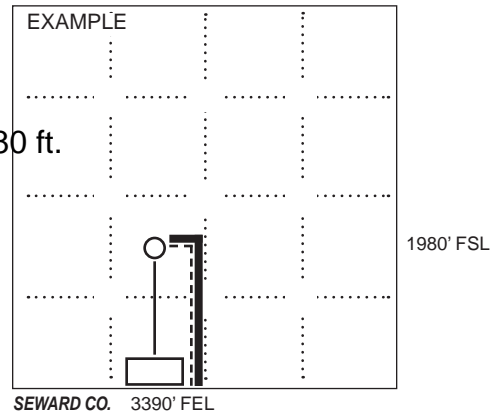

NOTE: In all cases locate the spot of the proposed drilling locaton.

1980 ft.

In plotting the proposed location of the well, you must show:

1. The manner in which you are using the depicted plat by identifying section lines, i.e. 1 section, 1 section with 8 surrounding sections, 4 sections, etc.
2. The distance of the proposed drilling location from the south / north and east / west outside section lines.
3. The distance to the nearest lease or unit boundary line (in footage).
4. If proposed location is located within a prorated or spaced field a certificate of acreage attribution plat must be attached: (C0-7 for oil wells; CG-8 for gas wells).
5. The predicted locations of lease roads, tank batteries, pipelines, and electrical lines.

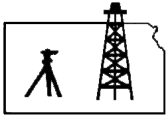

Pro-Stake LLC

Oil Field & Construction Site Staking

P.O. Box 2324
Garden City, Kansas 67846
Office/Fax: (620) 276-6159
Cell: (620) 272-1499

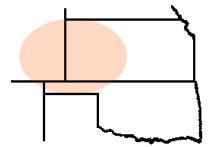

23124bar
PLAT NO.

10946
INVOICE NO.

O'Brien Energy Resources Corp.

OPERATOR

Prather #1-4

LEASE NAME

Clark Co, Ks

COUNTY

4 31s 24w
Sec. Twp. Rng.

1980' FSL - 1980' FEL

LOCATION SPOT

SCALE: **1" = 1000'**
DATE STAKED: **June 13th, 2013**
MEASURED BY: **Luke R.**
DRAWN BY: **Drew H.**
AUTHORIZED BY: **Ed S.**



GR. ELEVATION: **2560.8'**

Directions: From the North side of Minneola Ks at the intersection of Hwy 54 & Hwy 283 – Now go 4 miles South on Hwy 283 – Now go 0.6 mile East on Hwy 283 – Now go 3.1 miles East on G Rd to the NW corner of section 4-31s-24w – Now go 1 mile South on Rd 10 – Now go 0.7 mile East on Rd H to ingress stake North into – Now go 1980' North through wheat into staked location.

Final ingress must be verified with land owner or Operator.

This drawing does not constitute a monumented survey or a land survey plat.
This drawing is for construction purposes only.

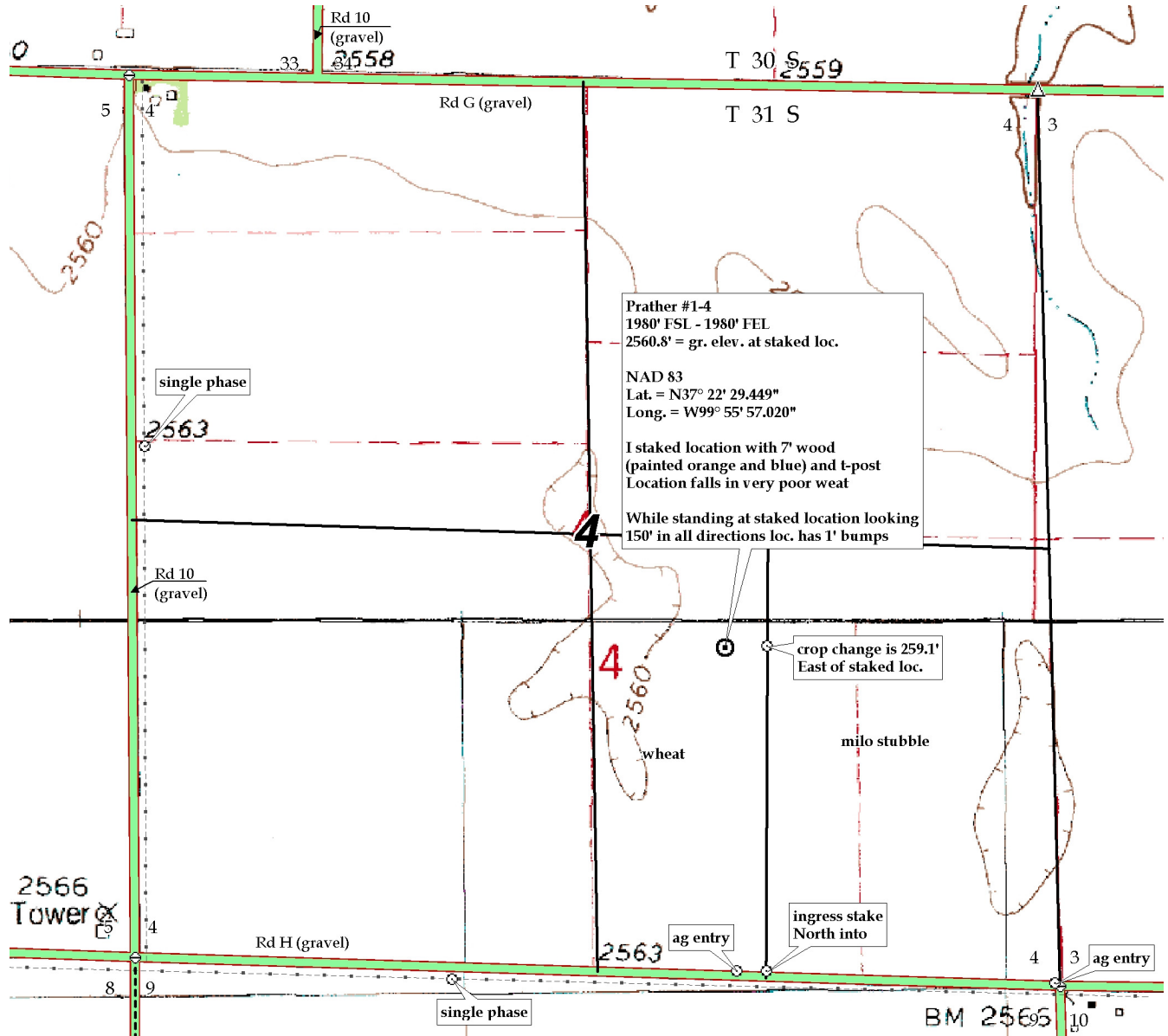



Pro-Stake LLC

Oil Field & Construction Site Staking

P.O. Box 2324
Garden City, Kansas 67846
Office/Fax: (620) 276-6159
Cell: (620) 272-1499

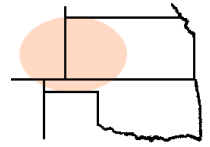

23124bar
PLAT NO.

10946
INVOICE NO.

O'Brien Energy Resources Corp.

OPERATOR

Prather #1-4

LEASE NAME

Clark Co, Ks
COUNTY

4 31s 24w
Sec. Twp. Rng.

1980' FSL - 1980' FEL

LOCATION SPOT

SCALE: N/A
DATE STAKED: June 13th, 2013
MEASURED BY: Luke R.
DRAWN BY: Drew H.
AUTHORIZED BY: Ed S.



GR. ELEVATION: **2560.8'**

Directions: From the North side of Minneola Ks at the intersection of Hwy 54 & Hwy 283 – Now go 4 miles South on Hwy 283 – Now go 0.6 mile East on Hwy 283 – Now go 3.1 miles East on G Rd to the NW corner of section 4-31s-24w – Now go 1 mile South on Rd 10 – Now go 0.7 mile East on Rd H to ingress stake North into – Now go 1980' North through wheat into staked location.

Final ingress must be verified with land owner or Operator.

This drawing does not constitute a monumented survey or a land survey plat.
This drawing is for construction purposes only.

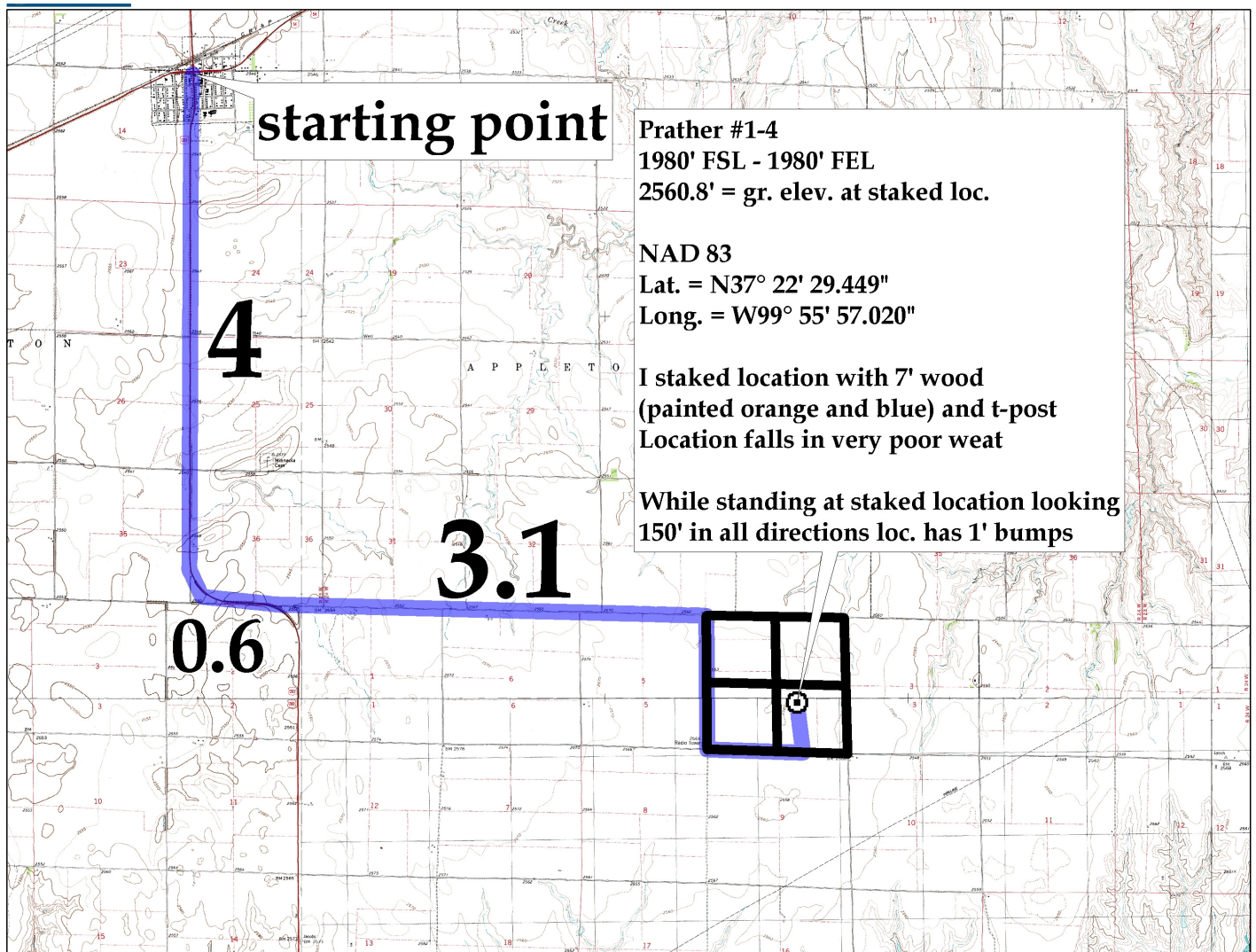



Pro-Stake LLC

Oil Field & Construction Site Staking

P.O. Box 2324
Garden City, Kansas 67846
Office/Fax: (620) 276-6159
Cell: (620) 272-1499

burt@pro-stakelc.kscoxmail.com



023124bar
PLAT NO.

11370
INVOICE NO.

O'Brien Energy Resources, Corp

OPERATOR

Ardrey #3-35

LEASE NAME

Clarke County, KS

COUNTY

35 30s 24w
Sec. Twp. Rng.

335' FSL - 1601' FEL

LOCATION SPOT

SCALE: **1" = 1000'**

DATE STAKED: **Dec. 5th, 2013**

MEASURED BY: **Ben R.**

DRAWN BY: **Drew H.**

AUTHORIZED BY: **Paul W.**

GR. ELEVATION: **2534.8'**



Directions: From the North side of Minneola Ks at the intersection of Hwy 54 & Hwy 283 – Now go 4 miles South on Hwy 283 – Now go 0.6 mile East on Hwy 283 – Now go 4.1 miles East on G Rd to the SW corner of section 35-30s-24w – Now go 0.8 mile East on G Rd to ingress stake NW into – Now go approx. 520' NW through wheat stubble into staked location.

Final ingress must be verified with land owner or Operator.

This drawing does not constitute a monumented survey or a land survey plat. This drawing is for construction purposes only.

