

For KCC Use ONLY  
 API # 15 - \_\_\_\_\_

**IN ALL CASES PLOT THE INTENDED WELL ON THE PLAT BELOW**

In all cases, please fully complete this side of the form. Include items 1 through 5 at the bottom of this page.

Operator: N & W Enterprises, Inc.  
 Lease: Giefer Southeast  
 Well Number: 6  
 Field: Walnut SE  
 Number of Acres attributable to well: \_\_\_\_\_  
 QTR/QTR/QTR/QTR of acreage: SW - NW - NE - SE

Location of Well: County: Crawford  
 \_\_\_\_\_  
 2145 feet from  N /  S Line of Section  
 \_\_\_\_\_  
 1155 feet from  E /  W Line of Section  
 Sec. 34 Twp. 28 S. R. 22  E  W

Is Section:  Regular or  Irregular

If Section is Irregular, locate well from nearest corner boundary.

Section corner used:  NE  NW  SE  SW

**PLAT**

Show location of the well. Show footage to the nearest lease or unit boundary line. Show the predicted locations of lease roads, tank batteries, pipelines and electrical lines, as required by the Kansas Surface Owner Notice Act (House Bill 2032).  
 You may attach a separate plat if desired.

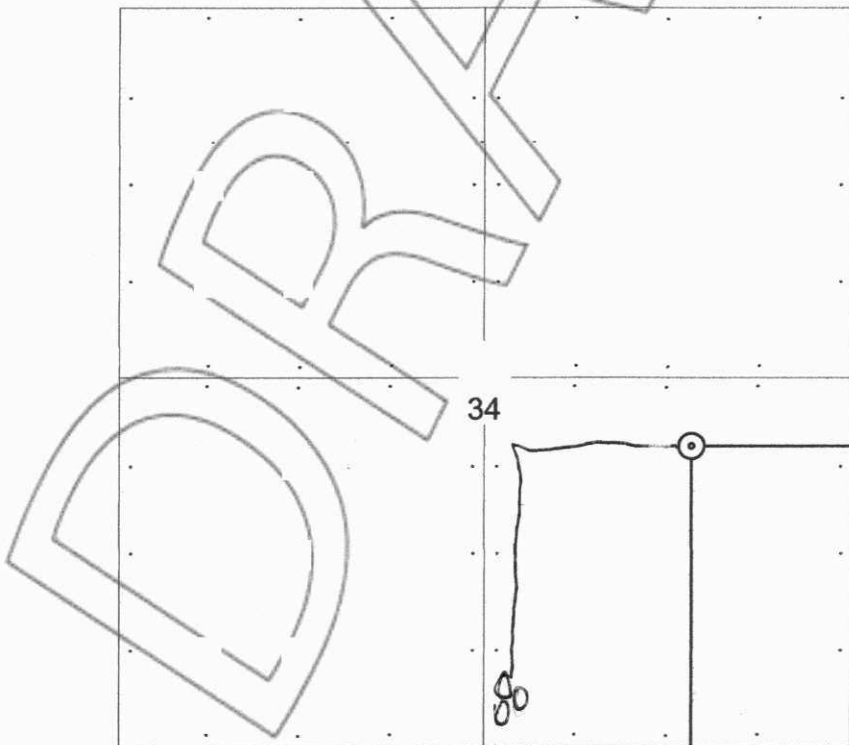

- LEGEND**
- Well Location
  - Tank Battery Location
  - Pipeline Location
  - Electric Line Location
  - Lease Road Location

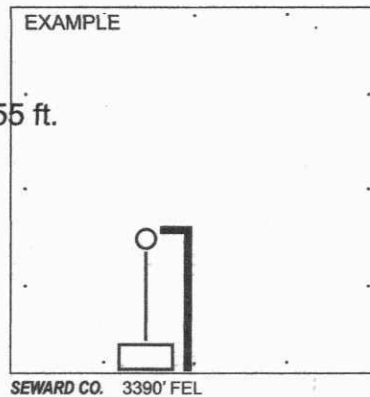

NOTE: In all cases locate the spot of the proposed drilling locaton.

2145 ft.

**In plotting the proposed location of the well, you must show:**

1. The manner in which you are using the depicted plat by identifying section lines, i.e. 1 section, 1 section with 8 surrounding sections, 4 sections, etc.
2. The distance of the proposed drilling location from the south / north and east / west outside section lines.
3. The distance to the nearest lease or unit boundary line (in footage).
4. If proposed location is located within a prorated or spaced field a certificate of acreage attribution plat must be attached: (CO-7 for oil wells; CG-8 for gas wells).
5. The predicted locations of lease roads, tank batteries, pipelines, and electrical lines.