

SURFACE TEMP: 96 DEG F
5 1/2" X 2 3/8" TUBING HEAD
SET TOP CLPG 12" AGL
G.L. ELEVATION 2349' (SHL)
KB: 23' -- KB ELEVATION: 2372'

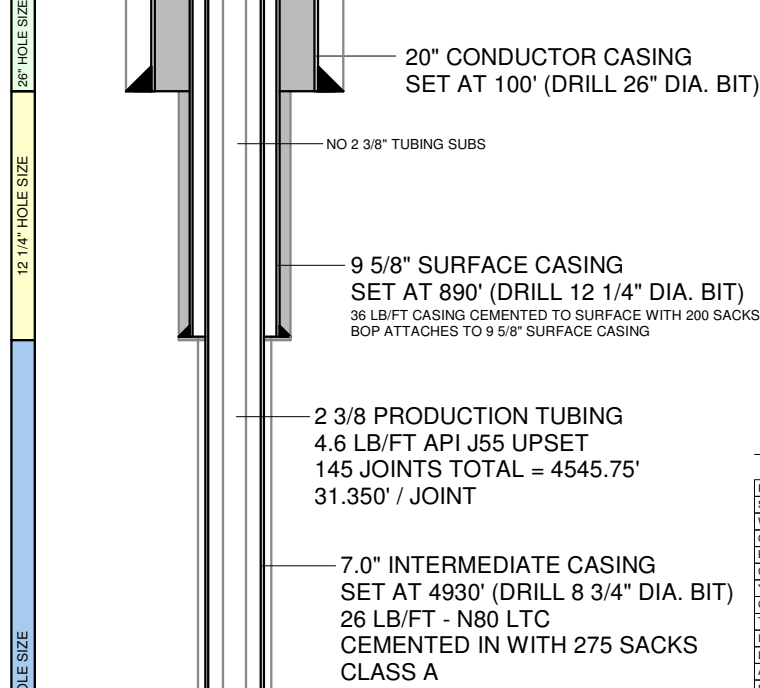

NOTES:
PUMPING UNIT: C - 160 - 240 - 74 (74" SURFACE STROKE)
CONVENTIONAL NATIONAL UNIT
40 HP ELECTRIC MOTOR WITH 30 HP SPOCC VFD
VFD INSTALLED
RUN TIME: 24 HRS PER DAY
1.25" X 14' POLISHED ROD WITH LINER ASSEMBLY (14' TOTAL)
1.50" HARD FACED POLISHED ROD LINER X 8'
2', 4', 6', & 8' PONY RODS ON TOP (3/4" GRADE N97) (20' TOTAL)
(177) 4425' OF 3/4" GRADE N97 SUCKER RODS (4425' TOTAL)
(3) 75' 1.5000" SINKER BARS ON BOTTOM (75' TOTAL)
ONE 2' X 3/4" GRADE N97 PONY ROD ON BOTTOM (TOP OF PUMP) (2' TOTAL)
SPEED RANGE: 4 TO 10 SPM (CURRENT SPEED 10 SPM)

TUBULARS

PURPOSE SIZE	CONDUCTOR 20"	SURFACE 9 5/8"	INTERMEDIATE 7"	SOLID LINER 4 1/2"	PROD. TUBING 2 3/8"
WEIGHT	94.00 LB/FT	36.0 LB/FT	26.00 LB/FT	15.50 LB/FT	6.40 LB/FT
GRADE	X-42	J-55	P-110 BUTTRESS	N-80	L-80
BURST	3,590 PSIG	3,520 PSIG	9,955 PSIG	10,480 PSIG	10,567 PSIG
COLLAPSE	N/A	2,020 PSIG	6,232 PSIG	11,080 PSIG	11,165 PSIG
YIELD	N/A	N/A	830,402 LBF	N/A	144,962 LBF
CAPACITY	0.355 BBLS/FT	N/A	0.038 BBLS/FT	N/A	0.243 GAL/FT
THICKNESS	0.4380"	0.3520"	0.3620"	0.3370"	0.2170"
ID	19.1240"	8.92100"	6.2760"	3.8260"	2.4410"
DRIFT ID	N/A	N/A	6.1510"	N/A	2.3470"
AREA	287.2423 IN2	N/A	30.9355 IN2	N/A	4.6798 IN2
SETTING DEPTH	100'	890'	4,930'	8,926'	4,824' TO SN
LENGTH	100'	890'	4,930'	8,926'	4,824'

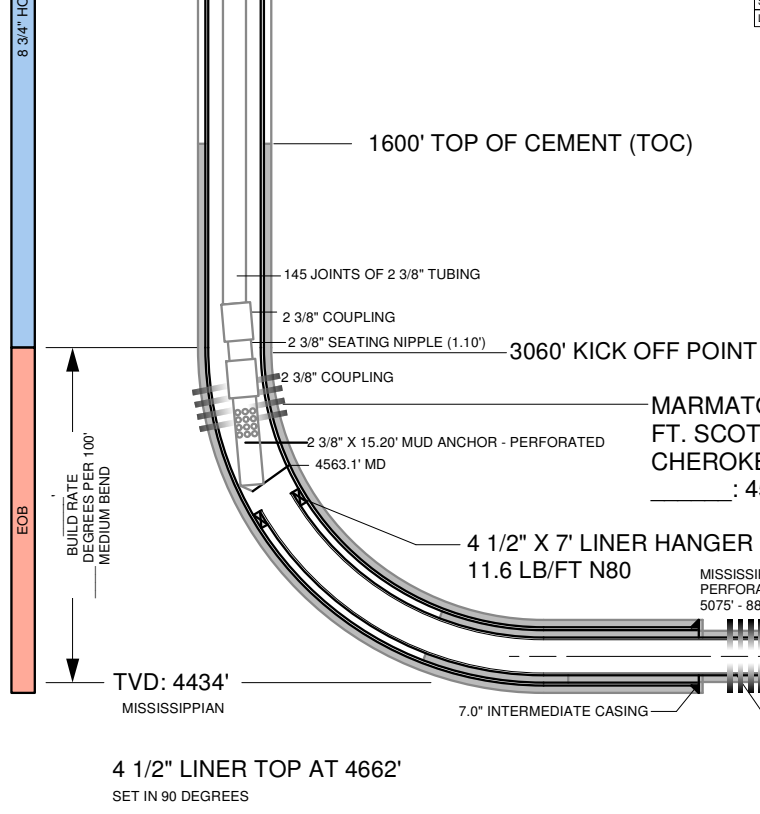

SEE WELL FILES FOR CEMENT DETAILS

DATE	05/19/2014
APPROVED BY	B. KELSO
AFE	4140-246
API No.	1513525-4180100
GL ELEVATION	2349' SH
KB	23' KB
KB ELEVATION	2372'
RIG	KELSO

4 1/2" LINER TOP AT 4662' SET IN 90 DEGREES
4 1/2" X 7' LINER HANGER AT 4662' 11.6 LB/FT N80
MISSISSIPPIAN PERFORATIONS (5 SPF) 5075' - 8872' MD
+ ' DRILLING WINDOW
- ' DRILLING WINDOW
4 1/2" PRODUCTION LINER (SOLID) 11.6 LB/FT N80 LTC SET AT 8,926' (DRILL 6 1/8" DIA. BIT) SOLID AND CEMENTED IN WITH 400 SACKS OF CLASS H
TD AT 8,933' MD
PBDT: 8,926 MD

DOWN HOLE SUCKER ROD PUMP:
1.5000" RWT INSERT PUMP (130" MAX STROKE)
PUMP LENGTH: 16' (NICARD AND SS)
BOTTOM HOLD DOWN TYPE TRAVELING BARREL
2' X 3/4" (N97) PONY ROD ON TOP OF PUMP
6" GAS SEPARATOR ON THE BOTTOM
PUMP INTAKE DEPTH: 4548'
PUMP IS SETTING ABOVE LATERAL IN CURVE IN 66 DEGREES

NICHEPOR #1-32H
NESS COUNTY, KANSAS
SHL: 200 FSL, 660 FEL
BHL: 330' FNL, 660 FEL
API NO.: 15-135-25418-01-00

