



1314166

For KCC Use ONLY

API # 15 - \_\_\_\_\_

**IN ALL CASES PLOT THE INTENDED WELL ON THE PLAT BELOW**

In all cases, please fully complete this side of the form. Include items 1 through 5 at the bottom of this page.

Operator: \_\_\_\_\_

Lease: \_\_\_\_\_

Well Number: \_\_\_\_\_

Field: \_\_\_\_\_

Number of Acres attributable to well: \_\_\_\_\_

QTR/QTR/QTR/QTR of acreage: \_\_\_\_\_ - \_\_\_\_\_ - \_\_\_\_\_ - \_\_\_\_\_

Location of Well: County: \_\_\_\_\_

\_\_\_\_\_ feet from  N /  S Line of Section

\_\_\_\_\_ feet from  E /  W Line of Section

Sec. \_\_\_\_\_ Twp. \_\_\_\_\_ S. R. \_\_\_\_\_  E  W

Is Section:  Regular or  Irregular

**If Section is Irregular, locate well from nearest corner boundary.**

Section corner used:  NE  NW  SE  SW

**PLAT**

Show location of the well. Show footage to the nearest lease or unit boundary line. Show the predicted locations of lease roads, tank batteries, pipelines and electrical lines, as required by the Kansas Surface Owner Notice Act (House Bill 2032).

You may attach a separate plat if desired.

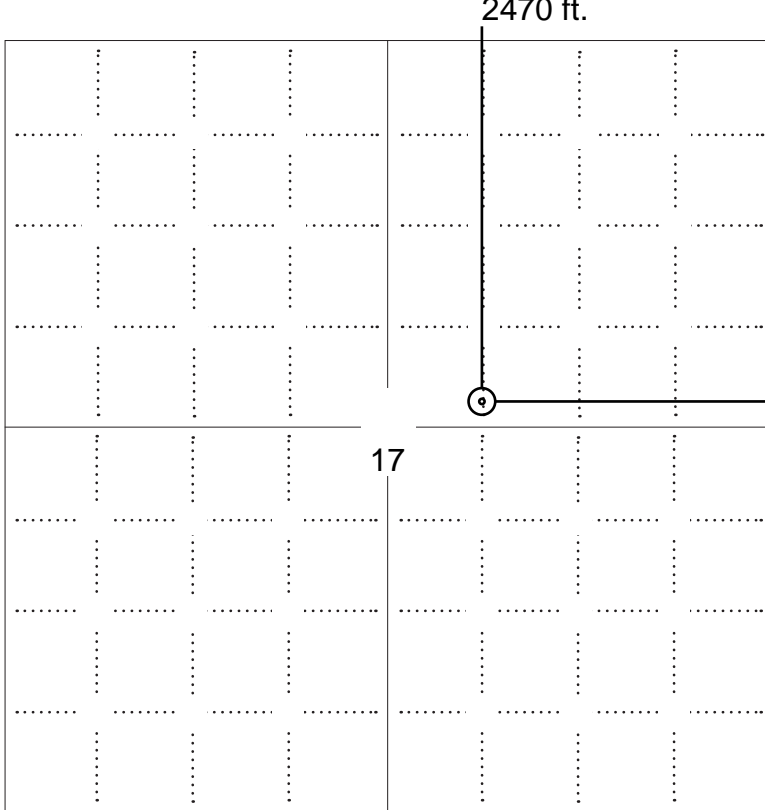

**LEGEND**

- Well Location
- Tank Battery Location
- Pipeline Location
- Electric Line Location
- Lease Road Location

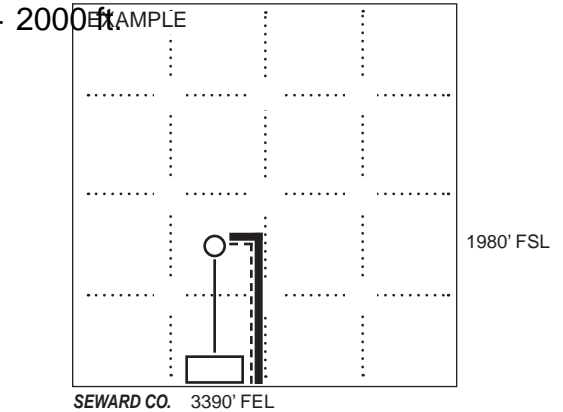

**NOTE: In all cases locate the spot of the proposed drilling locaton.**

**In plotting the proposed location of the well, you must show:**

1. The manner in which you are using the depicted plat by identifying section lines, i.e. 1 section, 1 section with 8 surrounding sections, 4 sections, etc.
2. The distance of the proposed drilling location from the south / north and east / west outside section lines.
3. The distance to the nearest lease or unit boundary line (in footage).
4. If proposed location is located within a prorated or spaced field a certificate of acreage attribution plat must be attached: (C0-7 for oil wells; CG-8 for gas wells).
5. The predicted locations of lease roads, tank batteries, pipelines, and electrical lines.



**APPLICATION FOR SURFACE PIT**

*Submit in Duplicate*

|   |  |  |  |
|---|--|--|--|
| Operator Name: _____  |  | License Number: _____  |  |
| Operator Address: _____   |  |  |  |
| Contact Person: _____   |  | Phone Number: _____  |  |
| Lease Name & Well No.: _____  |  | Pit Location (QQQQ):<br>_____-_____-_____-_____  |  |
| Type of Pit:<br><input type="checkbox"/> Emergency Pit <input type="checkbox"/> Burn Pit<br><input type="checkbox"/> Settling Pit <input type="checkbox"/> Drilling Pit<br><input type="checkbox"/> Workover Pit <input type="checkbox"/> Haul-Off Pit<br><i>(If WP Supply API No. or Year Drilled)</i>             |  | Pit is:<br><input type="checkbox"/> Proposed <input type="checkbox"/> Existing<br>If Existing, date constructed: _____<br>Pit capacity: _____ (bbls)   |  |
| Is the pit located in a Sensitive Ground Water Area? <input type="checkbox"/> Yes <input type="checkbox"/> No   |  | Chloride concentration: _____ mg/l<br><i>(For Emergency Pits and Settling Pits only)</i>   |  |
| Is the bottom below ground level?<br><input type="checkbox"/> Yes <input type="checkbox"/> No   |  | Artificial Liner?<br><input type="checkbox"/> Yes <input type="checkbox"/> No  |  |
| How is the pit lined if a plastic liner is not used?  |  |  |  |
| Pit dimensions (all but working pits): _____ Length (feet)    _____ Width (feet) <input type="checkbox"/> N/A: Steel Pits<br>Depth from ground level to deepest point: _____ (feet) <input type="checkbox"/> No Pit   |  |  |  |
| If the pit is lined give a brief description of the liner material, thickness and installation procedure.   |  | Describe procedures for periodic maintenance and determining liner integrity, including any special monitoring.  |  |
| Distance to nearest water well within one-mile of pit:<br>_____ feet    Depth of water well _____ feet  |  | Depth to shallowest fresh water _____ feet.<br>Source of information:<br><input type="checkbox"/> measured <input type="checkbox"/> well owner <input type="checkbox"/> electric log <input type="checkbox"/> KDWR   |  |
| <b>Emergency, Settling and Burn Pits ONLY:</b><br>Producing Formation: _____<br>Number of producing wells on lease: _____<br>Barrels of fluid produced daily: _____<br>Does the slope from the tank battery allow all spilled fluids to flow into the pit? <input type="checkbox"/> Yes <input type="checkbox"/> No |  | <b>Drilling, Workover and Haul-Off Pits ONLY:</b><br>Type of material utilized in drilling/workover: _____<br>Number of working pits to be utilized: _____<br>Abandonment procedure: _____<br>_____<br>Drill pits must be closed within 365 days of spud date. |  |
| Submitted Electronically  |  |  |  |

**KCC OFFICE USE ONLY**

Liner     Steel Pit     RFAC     RFAS

Date Received: \_\_\_\_\_ Permit Number: \_\_\_\_\_ Permit Date: \_\_\_\_\_ Lease Inspection:     Yes     No



### CERTIFICATION OF COMPLIANCE WITH THE KANSAS SURFACE OWNER NOTIFICATION ACT

*This form must be submitted with all Forms C-1 (Notice of Intent to Drill); CB-1 (Cathodic Protection Borehole Intent); T-1 (Request for Change of Operator Transfer of Injection or Surface Pit Permit); and CP-1 (Well Plugging Application). Any such form submitted without an accompanying Form KSONA-1 will be returned.*

Select the corresponding form being filed:  C-1 (Intent)  CB-1 (Cathodic Protection Borehole Intent)  T-1 (Transfer)  CP-1 (Plugging Application)

OPERATOR: License # \_\_\_\_\_  
Name: \_\_\_\_\_  
Address 1: \_\_\_\_\_  
Address 2: \_\_\_\_\_  
City: \_\_\_\_\_ State: \_\_\_\_\_ Zip: \_\_\_\_\_ + \_\_\_\_\_  
Contact Person: \_\_\_\_\_  
Phone: ( \_\_\_\_\_ ) \_\_\_\_\_ Fax: ( \_\_\_\_\_ ) \_\_\_\_\_  
Email Address: \_\_\_\_\_

Well Location:  
\_\_\_\_ - \_\_\_\_ - \_\_\_\_ - \_\_\_\_ Sec. \_\_\_\_ Twp. \_\_\_\_ S. R. \_\_\_\_  East  West  
County: \_\_\_\_\_  
Lease Name: \_\_\_\_\_ Well #: \_\_\_\_\_

*If filing a Form T-1 for multiple wells on a lease, enter the legal description of the lease below:*

**Surface Owner Information:**

Name: \_\_\_\_\_  
Address 1: \_\_\_\_\_  
Address 2: \_\_\_\_\_  
City: \_\_\_\_\_ State: \_\_\_\_\_ Zip: \_\_\_\_\_ + \_\_\_\_\_

*When filing a Form T-1 involving multiple surface owners, attach an additional sheet listing all of the information to the left for each surface owner. Surface owner information can be found in the records of the register of deeds for the county, and in the real estate property tax records of the county treasurer.*

*If this form is being submitted with a Form C-1 (Intent) or CB-1 (Cathodic Protection Borehole Intent), you must supply the surface owners and the KCC with a plat showing the predicted locations of lease roads, tank batteries, pipelines, and electrical lines. The locations shown on the plat are preliminary non-binding estimates. The locations may be entered on the Form C-1 plat, Form CB-1 plat, or a separate plat may be submitted.*

**Select one of the following:**

- I certify that, pursuant to the Kansas Surface Owner Notice Act (House Bill 2032), I have provided the following to the surface owner(s) of the land upon which the subject well is or will be located: 1) a copy of the Form C-1, Form CB-1, Form T-1, or Form CP-1 that I am filing in connection with this form; 2) if the form being filed is a Form C-1 or Form CB-1, the plat(s) required by this form; and 3) my operator name, address, phone number, fax, and email address.
- I have not provided this information to the surface owner(s). I acknowledge that, because I have not provided this information, the KCC will be required to send this information to the surface owner(s). To mitigate the additional cost of the KCC performing this task, I acknowledge that I must provide the name and address of the surface owner by filling out the top section of this form and that I am being charged a \$30.00 handling fee, payable to the KCC, which is enclosed with this form.

*If choosing the second option, submit payment of the \$30.00 handling fee with this form. If the fee is not received with this form, the KSONA-1 form and the associated Form C-1, Form CB-1, Form T-1, or Form CP-1 will be returned.*

I Submitted Electronically

I

For KCC Use ONLY  
 API # 15 - \_\_\_\_\_

**IN ALL CASES PLOT THE INTENDED WELL ON THE PLAT BELOW**

In all cases, please fully complete this side of the form. Include items 1 through 5 at the bottom of this page.

Operator: Culbreath Oil & Gas Company  
 Lease: Zerr  
 Well Number: 3-17  
 Field: Younkin West  
 Number of Acres attributable to well: 320  
 QTR/QTR/QTR/QTR of acreage: SE - SW - SW - NE

Location of Well: County: Logan  
2,470 feet from  N /  S Line of Section  
2,000 feet from  E /  W Line of Section  
 Sec. 17 Twp. 12 S. R. 32  E  W

Is Section:  Regular or  Irregular

If Section is Irregular, locate well from nearest corner boundary.  
 Section corner used:  NE  NW  SE  SW

**PLAT**

Show location of the well. Show footage to the nearest lease or unit boundary line. Show the predicted locations of lease roads, tank batteries, pipelines and electrical lines, as required by the Kansas Surface Owner Notice Act (House Bill 2032). You may attach a separate plat if desired.

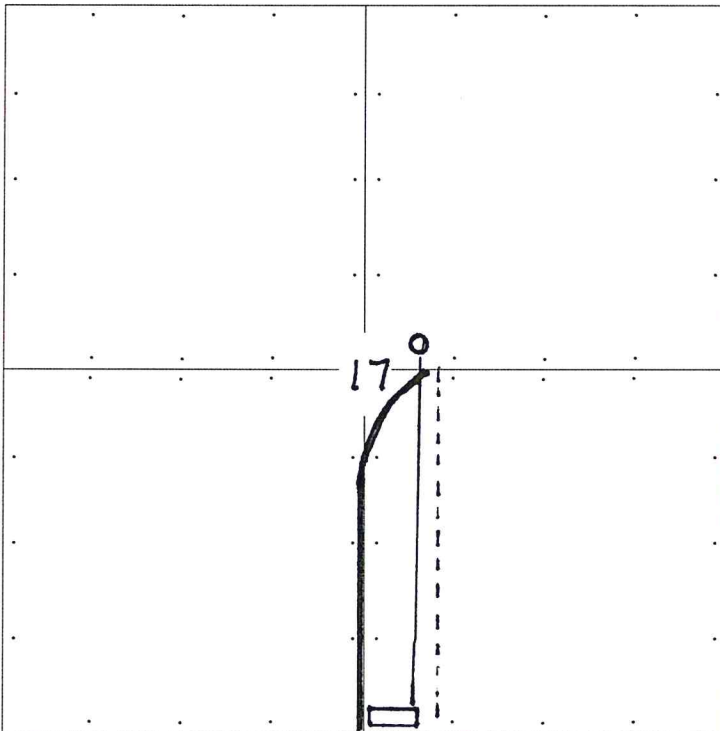

**LEGEND**

- Well Location
- Tank Battery Location
- Pipeline Location
- Electric Line Location
- Lease Road Location

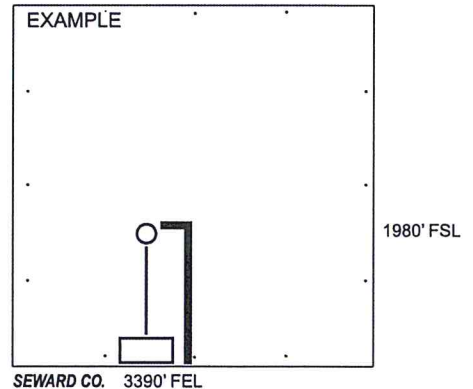

**NOTE: In all cases locate the spot of the proposed drilling locaton.**

**In plotting the proposed location of the well, you must show:**

1. The manner in which you are using the depicted plat by identifying section lines, i.e. 1 section, 1 section with 8 surrounding sections, 4 sections, etc.
2. The distance of the proposed drilling location from the south / north and east / west outside section lines.
3. The distance to the nearest lease or unit boundary line (in footage).
4. If proposed location is located within a prorated or spaced field a certificate of acreage attribution plat must be attached: (C0-7 for oil wells; CG-8 for gas wells).
5. The predicted locations of lease roads, tank batteries, pipelines, and electrical lines.



001232  
CRD NO.

# PRO-STAKE

Construction Site Staking

LLC

13093  
INVOICE NO.



**Culbreath Oil & Gas Company, Inc.**  
OPERATOR

**Logan County, KS**  
COUNTY

**17 12s 32w**  
Sec. Twp. Rng.

**Zerr #3-17**  
LEASE NAME

**2470' ENL - 2000' FEL**  
LOCATION SPOT

SCALE: 1" = 1000'  
DATE STAKED: Aug. 5<sup>th</sup>, 2016  
MEASURED BY: Kent C.  
DRAWN BY: Norby S.  
AUTHORIZED BY: Kevin H.  
DATE REVISED:

**3010.2'**  
GR. ELEVATION

P.O. Box 2324 Garden City, Kansas 67846  
Office/Fax: (620) 276-6159 – Cell: (620) 272-1499  
burt@prostakellc.com

### LEGEND

- ⊙ irr. well
- ⊕ water hydrant
- ⊙ tank battery
- ⊙ staked loc.
- ⊗ prod. well / aband. well
- house
- building
- G— gas line
- W— water line
- E— transmission powerline
- 3 phase powerline
- single phase powerline
- x—x—x— fence
- ▬ gravel / sand rd.
- ▬ gravel trail / lease rd.
- ▬ dirt rd.
- ▬ dirt trail / lease rd.
- ▬ Hwy / blacktop rd.



**DIRECTIONS:** From the South side of Oakley, KS at the intersection of Hwy 83 South & Hwy 40 – Now go 9 miles South on Hwy 83 – Now go 3 miles West on Ute – Now go 1 mile North on Rd. 410 to the SW corner of section 17-12s-32w and ingress stake East into – Now go 0.5 mile East on lease rd. to ingress stake North into – Now go 0.5 mile North on trail – Now go approx. 280' North through pasture, into staked location

**Final ingress must be verified with landowner or operator.**

*This drawing does not constitute a monumented survey or a land survey plat. This drawing is for construction purposes only.*

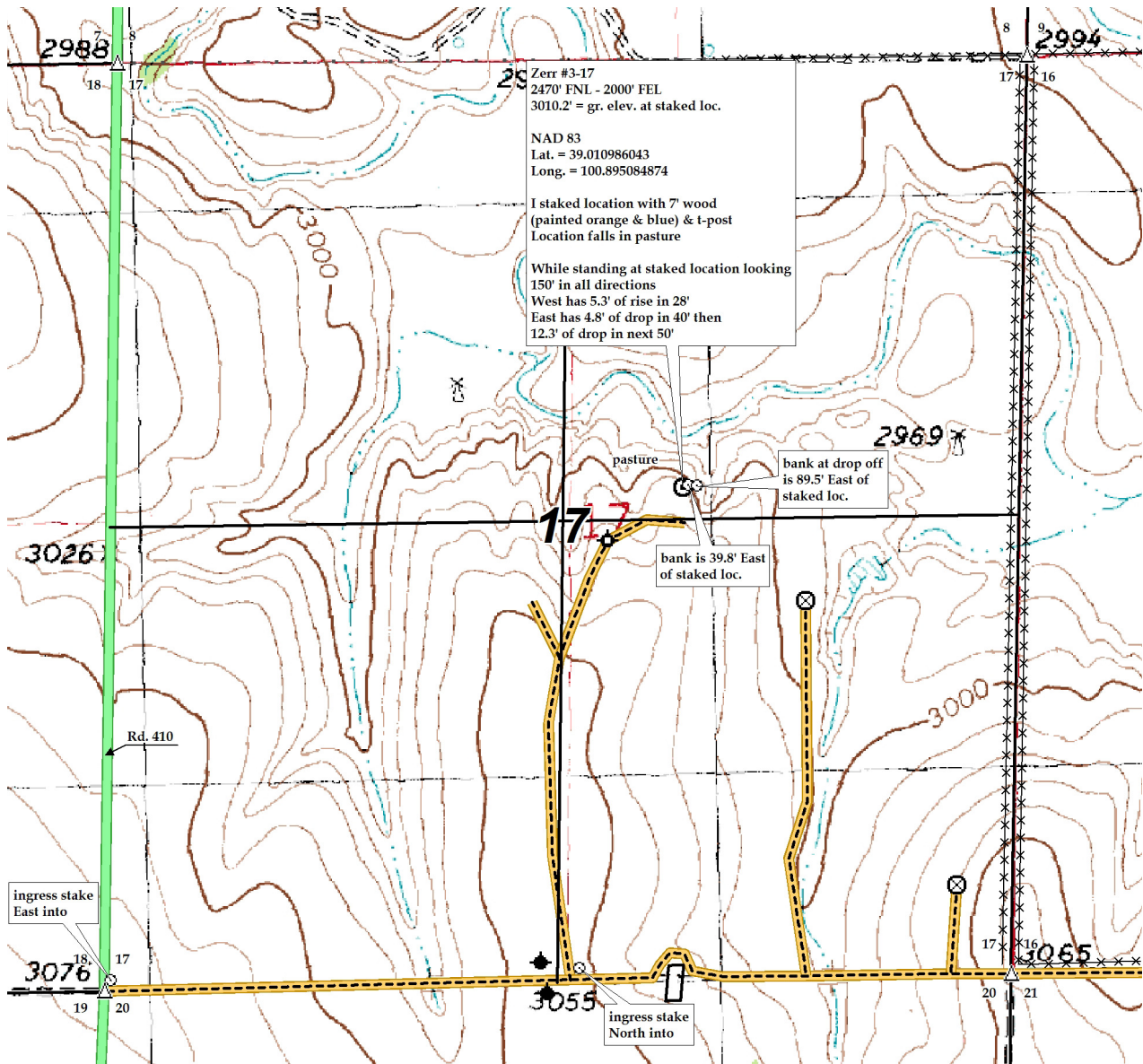

## NOTICE

### Nearest Lease or Unit Boundary Line

K.A.R. 82-3-108 provides that all oil and gas well locations must comply with setback requirements, unless an exception has been granted by the Commission. Depending upon whether the subject well is an oil well or gas well, and also depending upon the county in which the well is located, the setback may be 330 feet or 165 feet from the nearest lease or unit boundary.

This Intent to Drill (“C-1”) form indicates that the distance between the well and the nearest lease or unit boundary will comply with the setback requirement. Accordingly, the C-1 has been approved. However, the C-1 also stated that the well location is very near a boundary line of a Section or a Quarter-Section. This notice is being sent as a courtesy reminder, in case an error was made on the C-1.

As the operator of the proposed well, you must independently verify that the proposed well location complies with the applicable regulatory setback. If at any time it should appear that a well does not comply with the regulatory setback, the well may be subject to being shut-in pending Commission approval of an application for a well location exception. In addition, if such an application is not granted by the Commission, you may be required to plug the well.

If the proposed well location will comply with the regulatory setback, this notice may be disregarded. Please contact the KCC Production Department with any questions or concerns.

Conservation Division  
266 N. Main St., Ste. 220  
Wichita, KS 67202-1513



Phone: 316-337-6200  
Fax: 316-337-6211  
<http://kcc.ks.gov/>

Jay Scott Emler, Chairman  
Shari Feist Albrecht, Commissioner  
Pat Apple, Commissioner

Sam Brownback, Governor

August 12, 2016

Kevin Howard  
Culbreath Oil & Gas Company, Inc.  
3501 S YALE AVE  
TULSA, OK 74135-8014

Re: Drilling Pit Application  
Zerr 3-17  
NE/4 Sec.17-12S-32W  
Logan County, Kansas

Dear Kevin Howard:

District staff has inspected the above referenced location and has determined that the reserve pit shall be constructed **without slots**, the bottom shall be flat and reasonably level, and the free fluids must be removed. The fluids are to be removed from the reserve pit within 72 hours of completion of drilling operations.

KEEP PITS away from draw/drainage.

**If production casing is set all completion fluids shall be removed from the working pits daily. NO completion fluids or non-exempt wastes shall be placed in the reserve pit.**

The fluids should be taken to an authorized disposal well. Please call the District Office at (785) 625-0550 when the fluids have been removed. Please file form CDP-5 (August 2008), Exploration and Production Waste Transfer, through KOLAR within 30 days of fluid removal.

**A copy of this letter should be posted in the doghouse along with the approved Intent to Drill.** If you have any questions or concerns please feel free to contact the District Office at (785) 625-0550.