

KANSAS CORPORATION COMMISSION
OIL & GAS CONSERVATION DIVISION

Form CP-1
March 2010

This Form must be Typed
Form must be Signed
All blanks must be Filled

WELL PLUGGING APPLICATION

Form KSONA-1, Certification of Compliance with the Kansas Surface Owner Notification Act,
MUST be submitted with this form.

OPERATOR: License #: _____
Name: _____
Address 1: _____
Address 2: _____
City: _____ State: _____ Zip: _____ + _____
Contact Person: _____
Phone: (_____) _____

API No. 15 - _____
If pre 1967, supply original completion date: _____
Spot Description: _____
____ - ____ - ____ Sec. ____ Twp. ____ S. R. ____ East West
____ Feet from North / South Line of Section
____ Feet from East / West Line of Section
Footages Calculated from Nearest Outside Section Corner:
 NE NW SE SW
County: _____
Lease Name: _____ Well #: _____

Check One: Oil Well Gas Well OG D&A Cathodic Water Supply Well Other: _____
 SWD Permit #: _____ ENHR Permit #: _____ Gas Storage Permit #: _____

Conductor Casing Size: _____ Set at: _____ Cemented with: _____ Sacks
Surface Casing Size: _____ Set at: _____ Cemented with: _____ Sacks
Production Casing Size: _____ Set at: _____ Cemented with: _____ Sacks

List (ALL) Perforations and Bridge Plug Sets:

Elevation: _____ (G.L. / K.B.) T.D.: _____ PBTD: _____ Anhydrite Depth: _____
(Stone Corral Formation)

Condition of Well: Good Poor Junk in Hole Casing Leak at: _____
(Interval)

Proposed Method of Plugging (attach a separate page if additional space is needed):

Is Well Log attached to this application? Yes No Is ACO-1 filed? Yes No

If ACO-1 not filed, explain why:

Plugging of this Well will be done in accordance with K.S.A. 55-101 et. seq. and the Rules and Regulations of the State Corporation Commission

Company Representative authorized to supervise plugging operations: _____
Address: _____ City: _____ State: _____ Zip: _____ + _____
Phone: (_____) _____
Plugging Contractor License #: _____ Name: _____
Address 1: _____ Address 2: _____
City: _____ State: _____ Zip: _____ + _____
Phone: (_____) _____

Proposed Date of Plugging (if known): _____

Payment of the Plugging Fee (K.A.R. 82-3-118) will be guaranteed by Operator or Agent

Submitted Electronically

KANSAS CORPORATION COMMISSION
OIL & GAS CONSERVATION DIVISION

Form KSONA-1
January 2014
Form Must Be Typed
Form must be Signed
All blanks must be Filled

**CERTIFICATION OF COMPLIANCE WITH THE
KANSAS SURFACE OWNER NOTIFICATION ACT**

This form must be submitted with all Forms C-1 (Notice of Intent to Drill); CB-1 (Cathodic Protection Borehole Intent); T-1 (Request for Change of Operator Transfer of Injection or Surface Pit Permit); and CP-1 (Well Plugging Application). Any such form submitted without an accompanying Form KSONA-1 will be returned.

Select the corresponding form being filed: C-1 (Intent) CB-1 (Cathodic Protection Borehole Intent) T-1 (Transfer) CP-1 (Plugging Application)

OPERATOR: License # _____
Name: _____
Address 1: _____
Address 2: _____
City: _____ State: _____ Zip: _____ + _____
Contact Person: _____
Phone: (_____) _____ Fax: (_____) _____
Email Address: _____

Well Location:
____ - ____ - ____ - ____ Sec. ____ Twp. ____ S. R. ____ East West
County: _____
Lease Name: _____ Well #: _____

If filing a Form T-1 for multiple wells on a lease, enter the legal description of the lease below:

Surface Owner Information:

Name: _____
Address 1: _____
Address 2: _____
City: _____ State: _____ Zip: _____ + _____

When filing a Form T-1 involving multiple surface owners, attach an additional sheet listing all of the information to the left for each surface owner. Surface owner information can be found in the records of the register of deeds for the county, and in the real estate property tax records of the county treasurer.

If this form is being submitted with a Form C-1 (Intent) or CB-1 (Cathodic Protection Borehole Intent), you must supply the surface owners and the KCC with a plat showing the predicted locations of lease roads, tank batteries, pipelines, and electrical lines. The locations shown on the plat are preliminary non-binding estimates. The locations may be entered on the Form C-1 plat, Form CB-1 plat, or a separate plat may be submitted.

Select one of the following:

- I certify that, pursuant to the Kansas Surface Owner Notice Act (House Bill 2032), I have provided the following to the surface owner(s) of the land upon which the subject well is or will be located: 1) a copy of the Form C-1, Form CB-1, Form T-1, or Form CP-1 that I am filing in connection with this form; 2) if the form being filed is a Form C-1 or Form CB-1, the plat(s) required by this form; and 3) my operator name, address, phone number, fax, and email address.
- I have not provided this information to the surface owner(s). I acknowledge that, because I have not provided this information, the KCC will be required to send this information to the surface owner(s). To mitigate the additional cost of the KCC performing this task, I acknowledge that I must provide the name and address of the surface owner by filling out the top section of this form and that I am being charged a \$30.00 handling fee, payable to the KCC, which is enclosed with this form.

If choosing the second option, submit payment of the \$30.00 handling fee with this form. If the fee is not received with this form, the KSONA-1 form and the associated Form C-1, Form CB-1, Form T-1, or Form CP-1 will be returned.

I Submitted Electronically

I

Noble Energy Inc.
West Hiss W-07
NE NE SW Section 36, T20S-R14W
Barton County, Kansas
CURRENT WELLBORE SCHEMATIC
7/29/2008

GL Elev: 1908
KB Elev: 1910
Spud Date: 3/4/45
Completed: 4/3/1945

Surface Casing :

8-5/8" set at 620.

Production Casing :

5 1/2" set at 3,480'.
Cemented with 50
sks

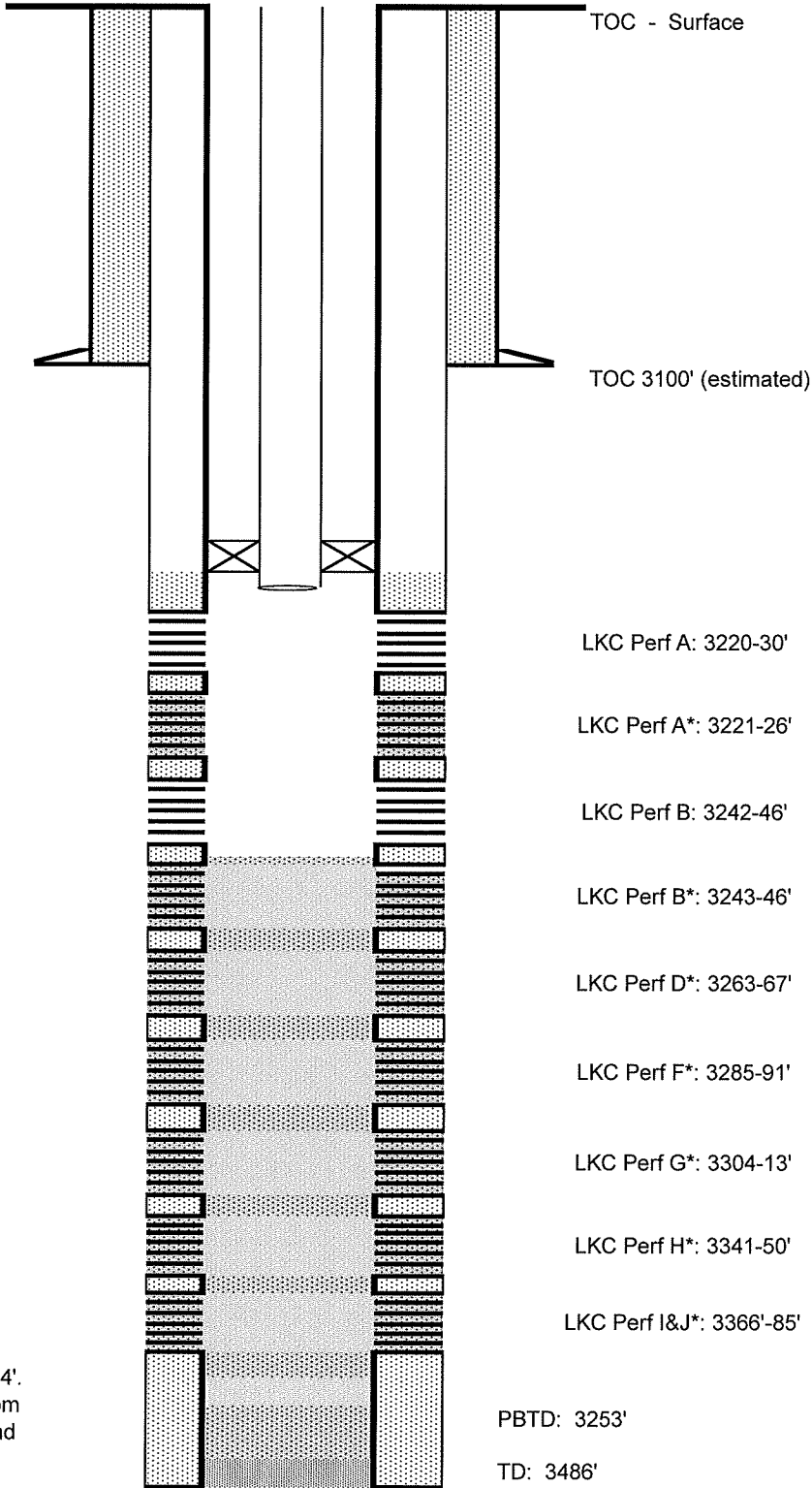

Cement from 3253'-3304'.
Scale and Sediment from
3304-45'. Csg shoe and
cmt from 3445' to TD.

PBTD: 3253'

TD: 3486'

J. Ostrum

January 17, 2019

Sharon Ward
Citation Oil & Gas Corp.
14077 CUTTEN RD
PO BOX 690688
HOUSTON, TX 77269-0688

Re: Plugging Application
API 15-009-07175-00-02
W HISS LKC W 07
SW/4 Sec.36-20S-14W
Barton County, Kansas

Dear Sharon Ward:

The Conservation Division has received your Well Plugging Application (CP-1).

Under K.A.R. 82-3-113(b)(2), you must notify DISTRICT 4 of your proposed plugging plan at least 5 days before plugging the well. DISTRICT 4's phone number is (785) 261-6250. Failure to notify DISTRICT 4, or failure to file a Well Plugging Record (CP-4) after the well is plugged will result in a penalty recommendation.

Under K.A.R. 82-3-600, you must file an Application for Surface Pit (CDP-1) if you wish to use a workover pit while plugging the well. Failure to timely file a CDP-1, failure to timely remove fluids, or failure to timely file Closure of Surface Pit (CDP-4) or Waste Transfer (CDP-5) forms will result in a penalty recommendation.

This receipt does NOT constitute authorization to plug this well if you do not otherwise have the legal right to do so.

This receipt is VOID after July 17, 2019. If the well is not plugged by then, you will have to submit a new CP-1 if you wish to plug the well.

The July 17, 2019 deadline does NOT override any compliance deadline given to you by Legal, District, or other Commission Staff. Failure to comply with any given deadline will still result in the Commission assessing penalties, or taking other legal action.

Sincerely,
Production Department Supervisor

cc: DISTRICT 4