

KSONA - Potential Tank Battery Location and Lease Road

PLOT OF THE INTENDED WELL

Operator: McCoy Petroleum Corporation
 Lease: R&S GATES "A" #1-2
 Well Number: #1-2
 Field: Wildcat
 Number of Acres attributable to well: 160
 QTR/QTR/QTR/QTR of acreage: SW

Location of Well: County: N2 NW SW Haskell County
2310 feet from N / S Line of Section
660 feet from E / W Line of Section
 Sec 2 Twp. 30 S Rng. 31 E W
 Is Section Regular or Irregular

If Section is Irregular, locate well from nearest corner boundary.
 Section corner used: NE NW SE SW

PLAT

Show the predicted locations of lease roads, tank batteries, pipelines and electrical lines,
 as required by the Kansas Surface Owner Notice Act (House Bill 2032).

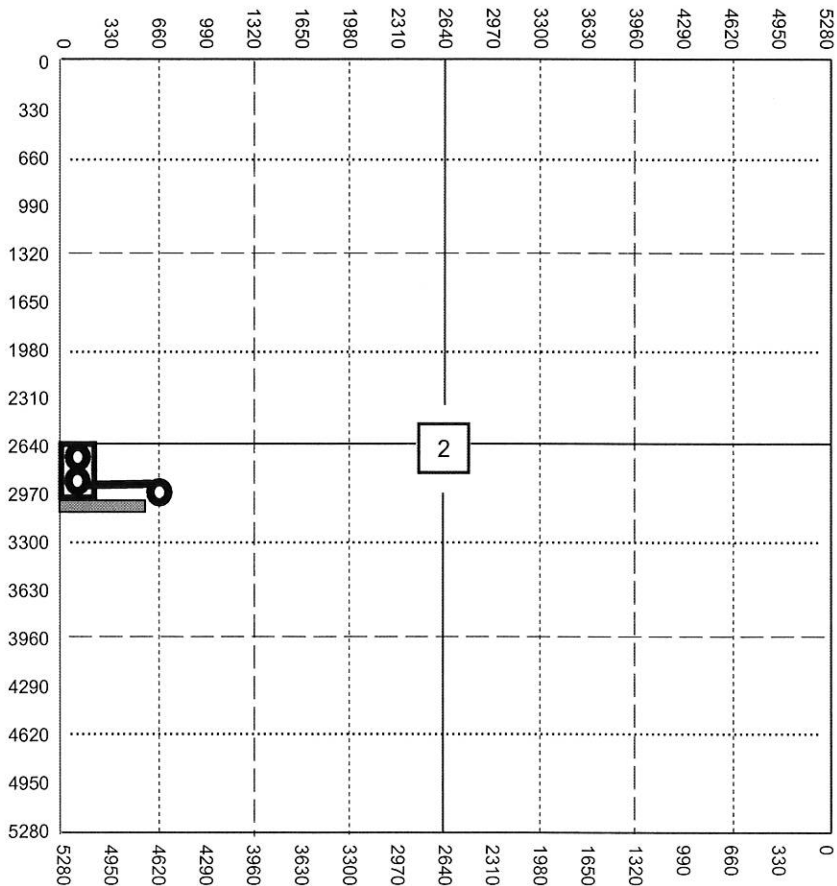

- LEGEND**
- Well Location
 - Tank Battery Location
 - Pipeline Location
 - Electric Line Location
 - Lease Road Location

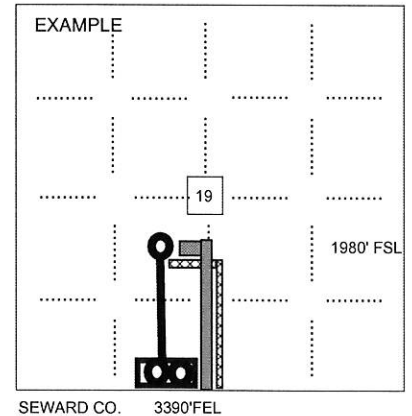

NOTE: Spot of the proposed drilling location.