

KANSAS CORPORATION COMMISSION  
OIL & GAS CONSERVATION DIVISION

Form CP-1  
March 2010

This Form must be Typed  
Form must be Signed  
All blanks must be Filled

**WELL PLUGGING APPLICATION**

Form KSONA-1, Certification of Compliance with the Kansas Surface Owner Notification Act,  
MUST be submitted with this form.

OPERATOR: License #: \_\_\_\_\_  
Name: \_\_\_\_\_  
Address 1: \_\_\_\_\_  
Address 2: \_\_\_\_\_  
City: \_\_\_\_\_ State: \_\_\_\_\_ Zip: \_\_\_\_\_ + \_\_\_\_\_  
Contact Person: \_\_\_\_\_  
Phone: ( \_\_\_\_\_ ) \_\_\_\_\_

API No. 15 - \_\_\_\_\_  
If pre 1967, supply original completion date: \_\_\_\_\_  
Spot Description: \_\_\_\_\_  
\_\_\_\_ - \_\_\_\_ - \_\_\_\_ Sec. \_\_\_\_ Twp. \_\_\_\_ S. R. \_\_\_\_  East  West  
\_\_\_\_\_ Feet from  North /  South Line of Section  
\_\_\_\_\_ Feet from  East /  West Line of Section  
Footages Calculated from Nearest Outside Section Corner:  
 NE  NW  SE  SW  
County: \_\_\_\_\_  
Lease Name: \_\_\_\_\_ Well #: \_\_\_\_\_

Check One:  Oil Well  Gas Well  OG  D&A  Cathodic  Water Supply Well  Other: \_\_\_\_\_  
 SWD Permit #: \_\_\_\_\_  ENHR Permit #: \_\_\_\_\_  Gas Storage Permit #: \_\_\_\_\_

Conductor Casing Size: \_\_\_\_\_ Set at: \_\_\_\_\_ Cemented with: \_\_\_\_\_ Sacks  
Surface Casing Size: \_\_\_\_\_ Set at: \_\_\_\_\_ Cemented with: \_\_\_\_\_ Sacks  
Production Casing Size: \_\_\_\_\_ Set at: \_\_\_\_\_ Cemented with: \_\_\_\_\_ Sacks

List (ALL) Perforations and Bridge Plug Sets:

Elevation: \_\_\_\_\_ (  G.L. /  K.B. ) T.D.: \_\_\_\_\_ PBTD: \_\_\_\_\_ Anhydrite Depth: \_\_\_\_\_  
(Stone Corral Formation)

Condition of Well:  Good  Poor  Junk in Hole  Casing Leak at: \_\_\_\_\_  
(Interval)

Proposed Method of Plugging (attach a separate page if additional space is needed):

Is Well Log attached to this application?  Yes  No Is ACO-1 filed?  Yes  No

If ACO-1 not filed, explain why:

**Plugging of this Well will be done in accordance with K.S.A. 55-101 et. seq. and the Rules and Regulations of the State Corporation Commission**

Company Representative authorized to supervise plugging operations: \_\_\_\_\_  
Address: \_\_\_\_\_ City: \_\_\_\_\_ State: \_\_\_\_\_ Zip: \_\_\_\_\_ + \_\_\_\_\_  
Phone: ( \_\_\_\_\_ ) \_\_\_\_\_  
Plugging Contractor License #: \_\_\_\_\_ Name: \_\_\_\_\_  
Address 1: \_\_\_\_\_ Address 2: \_\_\_\_\_  
City: \_\_\_\_\_ State: \_\_\_\_\_ Zip: \_\_\_\_\_ + \_\_\_\_\_  
Phone: ( \_\_\_\_\_ ) \_\_\_\_\_

Proposed Date of Plugging (if known): \_\_\_\_\_

Payment of the Plugging Fee (K.A.R. 82-3-118) will be guaranteed by Operator or Agent

Submitted Electronically

KANSAS CORPORATION COMMISSION  
OIL & GAS CONSERVATION DIVISION

Form KSONA-1  
January 2014  
**Form Must Be Typed**  
**Form must be Signed**  
**All blanks must be Filled**

**CERTIFICATION OF COMPLIANCE WITH THE  
KANSAS SURFACE OWNER NOTIFICATION ACT**

*This form must be submitted with all Forms C-1 (Notice of Intent to Drill); CB-1 (Cathodic Protection Borehole Intent); T-1 (Request for Change of Operator Transfer of Injection or Surface Pit Permit); and CP-1 (Well Plugging Application). Any such form submitted without an accompanying Form KSONA-1 will be returned.*

Select the corresponding form being filed:  C-1 (Intent)  CB-1 (Cathodic Protection Borehole Intent)  T-1 (Transfer)  CP-1 (Plugging Application)

OPERATOR: License # \_\_\_\_\_  
Name: \_\_\_\_\_  
Address 1: \_\_\_\_\_  
Address 2: \_\_\_\_\_  
City: \_\_\_\_\_ State: \_\_\_\_\_ Zip: \_\_\_\_\_ + \_\_\_\_\_  
Contact Person: \_\_\_\_\_  
Phone: ( \_\_\_\_\_ ) \_\_\_\_\_ Fax: ( \_\_\_\_\_ ) \_\_\_\_\_  
Email Address: \_\_\_\_\_

Well Location:  
\_\_\_\_ - \_\_\_\_ - \_\_\_\_ - \_\_\_\_ Sec. \_\_\_\_ Twp. \_\_\_\_ S. R. \_\_\_\_  East  West  
County: \_\_\_\_\_  
Lease Name: \_\_\_\_\_ Well #: \_\_\_\_\_  
*If filing a Form T-1 for multiple wells on a lease, enter the legal description of the lease below:*

**Surface Owner Information:**

Name: \_\_\_\_\_  
Address 1: \_\_\_\_\_  
Address 2: \_\_\_\_\_  
City: \_\_\_\_\_ State: \_\_\_\_\_ Zip: \_\_\_\_\_ + \_\_\_\_\_

*When filing a Form T-1 involving multiple surface owners, attach an additional sheet listing all of the information to the left for each surface owner. Surface owner information can be found in the records of the register of deeds for the county, and in the real estate property tax records of the county treasurer.*

*If this form is being submitted with a Form C-1 (Intent) or CB-1 (Cathodic Protection Borehole Intent), you must supply the surface owners and the KCC with a plat showing the predicted locations of lease roads, tank batteries, pipelines, and electrical lines. The locations shown on the plat are preliminary non-binding estimates. The locations may be entered on the Form C-1 plat, Form CB-1 plat, or a separate plat may be submitted.*

**Select one of the following:**

- I certify that, pursuant to the Kansas Surface Owner Notice Act (House Bill 2032), I have provided the following to the surface owner(s) of the land upon which the subject well is or will be located: 1) a copy of the Form C-1, Form CB-1, Form T-1, or Form CP-1 that I am filing in connection with this form; 2) if the form being filed is a Form C-1 or Form CB-1, the plat(s) required by this form; and 3) my operator name, address, phone number, fax, and email address.
- I have not provided this information to the surface owner(s). I acknowledge that, because I have not provided this information, the KCC will be required to send this information to the surface owner(s). To mitigate the additional cost of the KCC performing this task, I acknowledge that I must provide the name and address of the surface owner by filling out the top section of this form and that I am being charged a \$30.00 handling fee, payable to the KCC, which is enclosed with this form.

*If choosing the second option, submit payment of the \$30.00 handling fee with this form. If the fee is not received with this form, the KSONA-1 form and the associated Form C-1, Form CB-1, Form T-1, or Form CP-1 will be returned.*

I Submitted Electronically

I

Form	CP1 - Well Plugging Application
Operator	Fossil Creek Energy, LLC
Well Name	J BOXBERGER 6
Doc ID	1484190

Perforations And Bridge Plug Sets

Perforation Top	Perforation Base	Formation	Bridge Plug Depth
2975	3018	LKC	2390
2358	2360	Tarkio	

**WELL BORE DIAGRAM**

Date: 10/2/2019 GR

WELL <b>Box J #6</b>	FIELD <b>Hall Gurney</b>	CO/ST <b>Russell County, KS</b>
<input checked="" type="checkbox"/> PRESENT COMPLETION	<input type="checkbox"/> RECOMMENDED COMPLETION	API # 15-167-06058
<b>PERMANENT WELL BORE DATA</b>		<b>DATA ON THIS COMPLETION</b>

Spud: 7/20/1941  
 Completed: 8/24/1941  
 Elevation: 1803' DF

In 1968 they ran a 1" pipe b/w the 10" and 5-1/2" and circulated 350 sks of cement to surface

Well was converted to an injector on 1/8/1968

There is mention that the Tarkio is open from 2365'-2369' 2347'-2353', & 2337' & 2343'. It isn't clear what is still open or closed, other than the Tarkio is open and has been frac'd

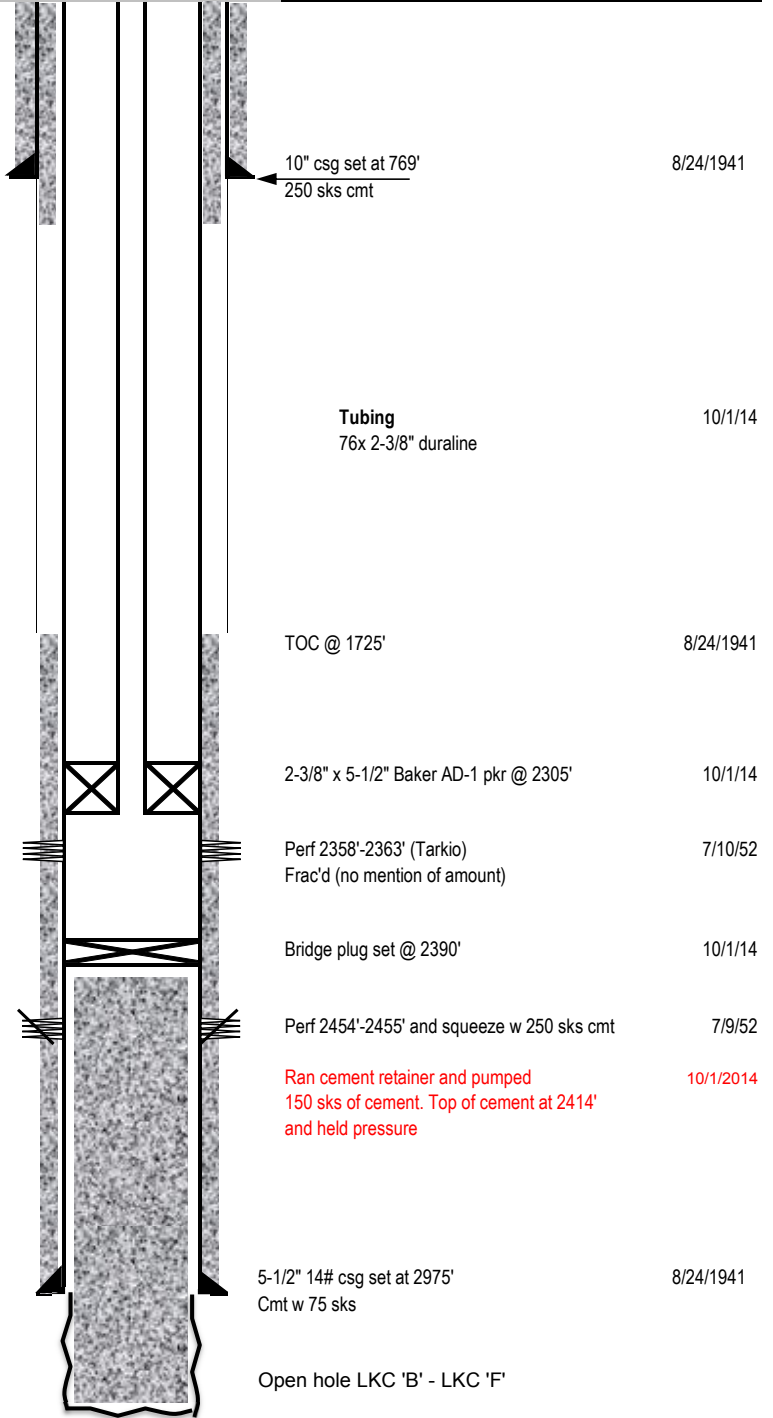

PBTD: 2390' (2014)  
 TD: 3018' (1941)

December 02, 2019

Gavin Ramsay  
Fossil Creek Energy, LLC  
PO BOX 915  
RUSSELL, KS 67665-0915

Re: Plugging Application  
API 15-167-06058-00-02  
J BOXBERGER 6  
NE/4 Sec.26-14S-14W  
Russell County, Kansas

Dear Gavin Ramsay:

The Conservation Division has received your Well Plugging Application (CP-1).

**Under K.A.R. 82-3-113(b)(2), you must notify DISTRICT 4 of your proposed plugging plan at least 5 days before plugging the well.** DISTRICT 4's phone number is (785) 261-6250. Failure to notify DISTRICT 4, or failure to file a Well Plugging Record (CP-4) after the well is plugged will result in a penalty recommendation.

**Under K.A.R. 82-3-600, you must file an Application for Surface Pit (CDP-1) if you wish to use a workover pit while plugging the well.** Failure to timely file a CDP-1, failure to timely remove fluids, or failure to timely file Closure of Surface Pit (CDP-4) or Waste Transfer (CDP-5) forms will result in a penalty recommendation.

This receipt does NOT constitute authorization to plug this well if you do not otherwise have the legal right to do so.

This receipt is VOID after May 30, 2020. If the well is not plugged by then, you will have to submit a new CP-1 if you wish to plug the well.

**The May 30, 2020 deadline does NOT override any compliance deadline given to you by Legal, District, or other Commission Staff.** Failure to comply with any given deadline will still result in the Commission assessing penalties, or taking other legal action.

Sincerely,  
Production Department Supervisor

cc: DISTRICT 4