

For KCC Use:
Effective Date:
District #
SGA? Yes No

KANSAS CORPORATION COMMISSION
OIL & GAS CONSERVATION DIVISION

Form CB-1
Oct 2016

Form must be Typed
Form must be Signed
All blanks must be Filled

CATHODIC PROTECTION BOREHOLE INTENT

Must be approved by the KCC sixty (60) days prior to commencing well.

Form KSONA-1, Certification of Compliance with the Kansas Surface Owner Notification Act, MUST be submitted with this form.

Expected Spud Date: month day year

OPERATOR: License#
Name:
Address 1:
Address 2:
City: State: Zip:
Contact Person:
Phone:

CONTRACTOR: License#
Name:
Type Drilling Equipment: Mud Rotary Cable Air Rotary Other

Construction Features

Length of Cathodic Surface (Non-Metallic) Casing
Planned to be set: feet
Length of Conductor pipe (if any): feet
Surface casing borehole size: inches
Cathodic surface casing size: inches
Cathodic surface casing centralizers set at depths of:
Cathodic surface casing will terminate at:
Above surface Surface Vault Below Surface Vault
Pitless casing adaptor will be used: Yes No Depth feet
Anode installation depths are:

Spot Description:
Sec. Twp. S. R. E W
feet from N S Line of Section
feet from E W Line of Section

Is SECTION: Regular Irregular?
(Check directions from nearest outside corner boundaries)

County:
Facility Name:
Borehole Number:
Ground Surface Elevation: MSL
Cathodic Borehole Total Depth: feet
Depth to Bedrock: feet

Water Information

Aquifer Penetration: None Single Multiple
Depth to bottom of fresh water:
Depth to bottom of usable water:
Water well within one-quarter mile: Yes No
Public water supply well within one mile: Yes No
Water Source for Drilling Operations: Well Farm Pond Stream Other

Water Well Location:
DWR Permit #
Standard Dimension Ratio (SDR) is =
(Cathodic surface csg. O.D. in inches / MWT in inches = SDR)
Annular space between borehole and casing will be grouted with:
Concrete Neat Cement Bentonite Cement Bentonite Clay
Anode vent pipe will be set at: feet above surface
Anode conductor (backfill) material TYPE:
Depth of BASE of Backfill installation material:
Depth of TOP of Backfill installation material:
Borehole will be Pre-Plugged? Yes No

AFFIDAVIT

The undersigned hereby affirms that the drilling, completion and eventual plugging of this well will comply with K.S.A. 55-101 et. seq.

It is agreed that the following minimum requirements will be met:

- 1. Notify the appropriate District office prior to spudding and again before plugging the well.
2. Notify appropriate District Office 48 hours prior to workover or re-entry.
3. A copy of the approved notice of intent to drill shall be posted on each drilling rig.
4. The minimum amount of cathodic surface casing as specified below shall be set by grouting to the top when the cathodic surface casing is set.
5. File all required forms: a. File Drill Pit Application (form CDP-1) with Intent to Drill (form CB-1). b. File Certification of Compliance with Kansas Surface Owner Notification Act (form KSONA-1) with Cathodic Protection Borehole Intent (CB-1) c. File Completion Form (ACO-1) within 60 days from spud date. d. Submit plugging report (CP-4) within 60 days after final plugging is completed.

Submitted Electronically

For KCC Use ONLY
API # 15 -
Conductor pipe required feet
Minimum Cathodic Surface Casing Required: feet
Approved by:
This authorization expires:
(This authorization void if drilling not started within 12 months of approval date.)
Spud date: Agent:

If this permit has expired or will not be drilled, check a box below, sign, date and return to the address below.

Permit Expired Well Not Drilled

Date

Signature of Operator or Agent

E
W

For KCC Use ONLY

API # 15 - _____

IN ALL CASES, PLEASE FULLY COMPLETE THIS SIDE OF THE FORM.

In all cases, please fully complete this side of the form. Include items 1 through 3 at the bottom of this page.

Operator: _____
 Facility Name: _____
 Borehole Number: _____

Location of Well: County: _____
 _____ feet from N / S Line of Section
 _____ feet from E / W Line of Section
 Sec. _____ Twp. _____ S. R. _____ E W

Is Section: Regular or Irregular

If Section is Irregular, locate well from nearest corner boundary.

Section corner used: NE NW SE SW

PLAT

Show location of the Cathodic Borehole. Show footage to the nearest lease or unit boundary line. Show the predicted locations of lease roads, tank batteries, pipelines and electrical lines, as required by the Kansas Surface Owner Notice Act (House Bill 2032). You may attach a separate plat if desired.

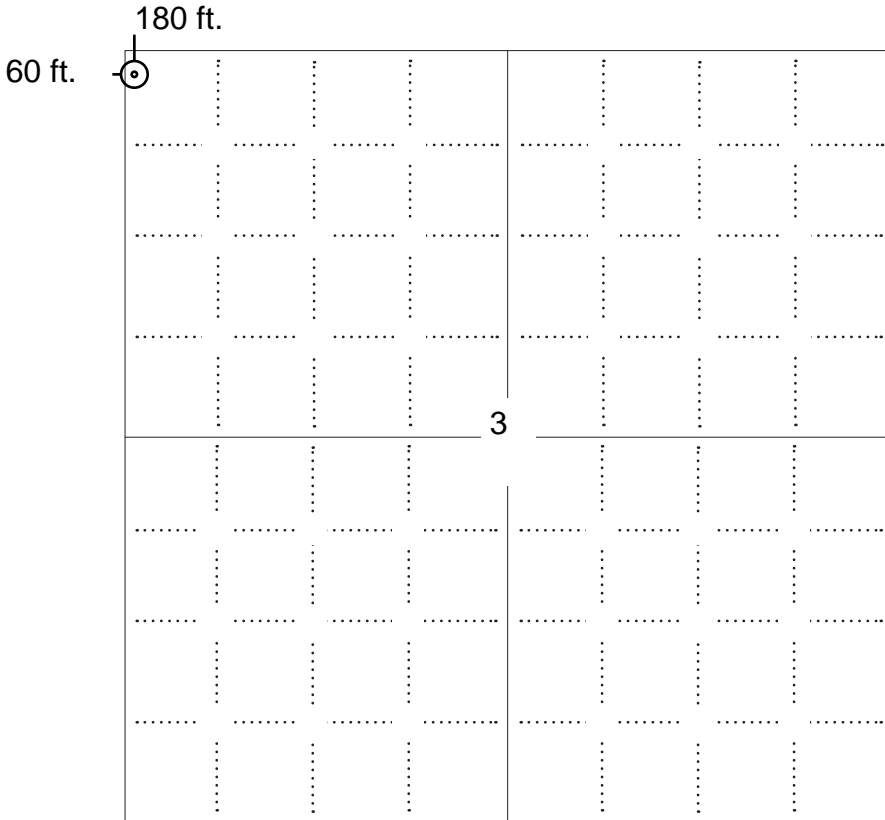

LEGEND

- Well Location
- Tank Battery Location
- Pipeline Location
- Electric Line Location
- Lease Road Location

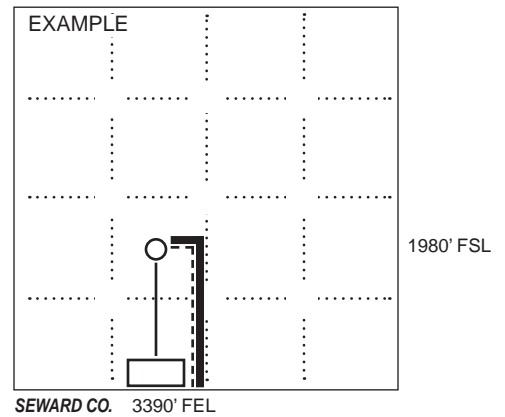

NOTE: In all cases locate the spot of the proposed drilling locaton.

In plotting the proposed location of the well, you must show:

1. The manner in which you are using the depicted plat by identifying section lines, i.e. 1 section, 1 section with 8 surrounding sections, 4 sections, etc.;
2. The distance of the proposed drilling location from the section's south / north and east / west; line.
3. The predicted locations of lease roads, tank batteries, pipelines, and electrical lines.

**KANSAS CORPORATION COMMISSION
OIL & GAS CONSERVATION DIVISION
APPLICATION FOR SURFACE PIT**

Form CDP-1
July 2014
Form must be Typed

Submit in Duplicate

Operator Name: _____		License Number: _____	
Operator Address: _____			
Contact Person: _____		Phone Number: _____	
Lease Name & Well No.: _____		Pit Location (QQQQ): _____-_____-_____-_____	
Type of Pit: <input type="checkbox"/> Emergency Pit <input type="checkbox"/> Burn Pit <input type="checkbox"/> Settling Pit <input type="checkbox"/> Drilling Pit <input type="checkbox"/> Workover Pit <input type="checkbox"/> Haul-Off Pit <i>(If WP Supply API No. or Year Drilled)</i>		Pit is: <input type="checkbox"/> Proposed <input type="checkbox"/> Existing If Existing, date constructed: _____ Pit capacity: _____ (bbls)	
Is the pit located in a Sensitive Ground Water Area? <input type="checkbox"/> Yes <input type="checkbox"/> No		Chloride concentration: _____ mg/l <i>(For Emergency Pits and Settling Pits only)</i>	
Is the bottom below ground level? <input type="checkbox"/> Yes <input type="checkbox"/> No		Artificial Liner? <input type="checkbox"/> Yes <input type="checkbox"/> No	
How is the pit lined if a plastic liner is not used?		_____	
Pit dimensions (all but working pits): _____ Length (feet) _____ Width (feet) <input type="checkbox"/> N/A: Steel Pits Depth from ground level to deepest point: _____ (feet) <input type="checkbox"/> No Pit			
If the pit is lined give a brief description of the liner material, thickness and installation procedure.		Describe procedures for periodic maintenance and determining liner integrity, including any special monitoring.	
Distance to nearest water well within one-mile of pit: _____ feet Depth of water well _____ feet		Depth to shallowest fresh water _____ feet. Source of information: <input type="checkbox"/> measured <input type="checkbox"/> well owner <input type="checkbox"/> electric log <input type="checkbox"/> KDWR	
Emergency, Settling and Burn Pits ONLY: Producing Formation: _____ Number of producing wells on lease: _____ Barrels of fluid produced daily: _____ Does the slope from the tank battery allow all spilled fluids to flow into the pit? <input type="checkbox"/> Yes <input type="checkbox"/> No		Drilling, Workover and Haul-Off Pits ONLY: Type of material utilized in drilling/workover: _____ Number of working pits to be utilized: _____ Abandonment procedure: _____ _____ Drill pits must be closed within 365 days of spud date.	
Submitted Electronically			

KCC OFFICE USE ONLY			
Date Received: _____	Permit Number: _____	Permit Date: _____	Lease Inspection: <input type="checkbox"/> Yes <input type="checkbox"/> No
<input type="checkbox"/> Liner		<input type="checkbox"/> Steel Pit <input type="checkbox"/> RFAC <input type="checkbox"/> RFAS	

KANSAS CORPORATION COMMISSION
OIL & GAS CONSERVATION DIVISION

Form KSONA-1

July 2021

Form Must Be Typed

Form must be Signed

All blanks must be Filled

**CERTIFICATION OF COMPLIANCE WITH THE
KANSAS SURFACE OWNER NOTIFICATION ACT**

This form must be submitted with all Forms C-1 (Notice of Intent to Drill); CB-1 (Cathodic Protection Borehole Intent); T-1 (Request for Change of Operator Transfer of Injection or Surface Pit Permit); and CP-1 (Well Plugging Application). Any such form submitted without an accompanying Form KSONA-1 will be returned.

Select the corresponding form being filed: C-1 (Intent) CB-1 (Cathodic Protection Borehole Intent) T-1 (Transfer) CP-1 (Plugging Application)

OPERATOR: License # _____

Name: _____

Address 1: _____

Address 2: _____

City: _____ State: _____ Zip: _____ + _____

Contact Person: _____

Phone: (_____) _____ Fax: (_____) _____

Email Address: _____

Well Location:

____ - ____ - ____ - ____ Sec. ____ Twp. ____ S. R. ____ East West

County: _____

Lease Name: _____ Well #: _____

If filing a Form T-1 for multiple wells on a lease, enter the legal description of the lease below:

Surface Owner Information:

Name: _____

Address 1: _____

Address 2: _____

City: _____ State: _____ Zip: _____ + _____

When filing a Form T-1 involving multiple surface owners, attach an additional sheet listing all of the information to the left for each surface owner. Surface owner information can be found in the records of the register of deeds for the county, and in the real estate property tax records of the county treasurer.

If this form is being submitted with a Form C-1 (Intent) or CB-1 (Cathodic Protection Borehole Intent), you must supply the surface owners and the KCC with a plat showing the predicted locations of lease roads, tank batteries, pipelines, and electrical lines. The locations shown on the plat are preliminary non-binding estimates. The locations may be entered on the Form C-1 plat, Form CB-1 plat, or a separate plat may be submitted.

Select one of the following:

- I certify that, pursuant to the Kansas Surface Owner Notice Act (see Chapter 55 of the Kansas Statutes Annotated), I have provided the following to the surface owner(s) of the land upon which the subject well is or will be located: 1) a copy of the Form C-1, Form CB-1, Form T-1, or Form CP-1 that I am filing in connection with this form; 2) if the form being filed is a Form C-1 or Form CB-1, the plat(s) required by this form; and 3) my operator name, address, phone number, fax, and email address.
- I have not provided this information to the surface owner(s). I acknowledge that, because I have not provided this information, the KCC will be required to send this information to the surface owner(s). To mitigate the additional cost of the KCC performing this task, I acknowledge that I must provide the name and address of the surface owner by filling out the top section of this form and that I am being charged a \$30.00 handling fee, payable to the KCC, which is enclosed with this form.

If choosing the second option, submit payment of the \$30.00 handling fee with this form. If the fee is not received with this form, the KSONA-1 form and the associated Form C-1, Form CB-1, Form T-1, or Form CP-1 will be returned.

I Submitted Electronically

I

Form	CB1CDP1 - Cathodic Protection Borehole Intent
Operator	Natural Gas Pipeline Company of America LLC
Well Name	AMA 355 1
Doc ID	1717521

Anode Installation Depths

Depth
325
315
305
295
285
275
265
255
245
235
225
215
205
195
185
175
165
155
145
135
125
115
105

For KCC Use ONLY
 API # 15 - _____

IN ALL CASES, PLEASE FULLY COMPLETE THIS SIDE OF THE FORM.

In all cases, please fully complete this side of the form. Include items 1 through 3 at the bottom of this page.

Operator: _____
 Facility Name: _____
 Borehole Number: _____

Location of Well: County: _____
 _____ feet from N / S Line of Section
 _____ feet from E / W Line of Section
 Sec. _____ Twp. _____ S. R. _____ E W

Is Section: Regular or Irregular

If Section is Irregular, locate well from nearest corner boundary.

Section corner used: NE NW SE SW

PLAT

Show location of the Cathodic Borehole. Show footage to the nearest lease or unit boundary line. Show the predicted locations of lease roads, tank batteries, pipelines and electrical lines, as required by the Kansas Surface Owner Notice Act (House Bill 2032). You may attach a separate plat if desired.

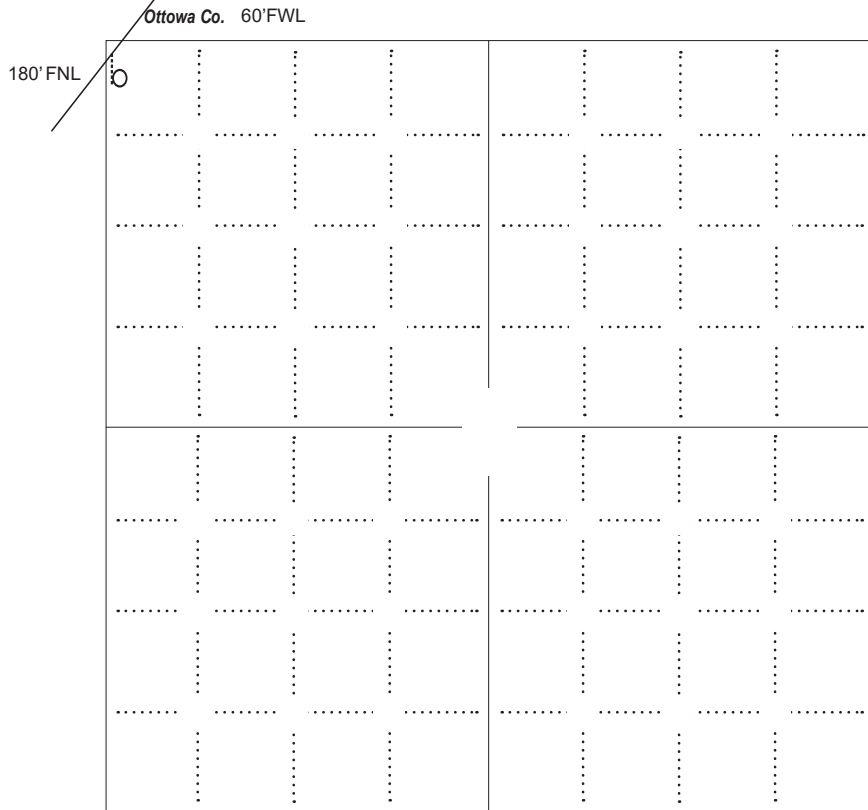

LEGEND

- Well Location
- Tank Battery Location
- Pipeline Location
- Electric Line Location
- Lease Road Location

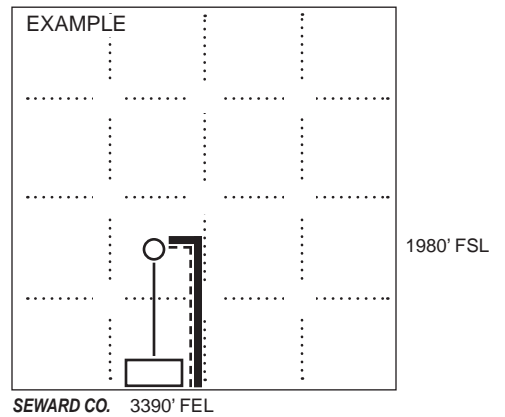

NOTE: In all cases locate the spot of the proposed drilling locaton.

In plotting the proposed location of the well, you must show:

1. The manner in which you are using the depicted plat by identifying section lines, i.e. 1 section, 1 section with 8 surrounding sections, 4 sections, etc.;
2. The distance of the proposed drilling location from the section's south / north and east / west; line.
3. The predicted locations of lease roads, tank batteries, pipelines, and electrical lines.



Conservation Division
266 N. Main St., Ste. 220
Wichita, KS 67202-1513

Phone: 316-337-6200
Fax: 316-337-6211
<http://kcc.ks.gov/>

Susan K. Duffy, Chair
Dwight D. Keen, Commissioner
Andrew J. French, Commissioner

Laura Kelly, Governor

According to the drilling pit application, no earthen pits will be used at this location. Steel pits will be used. Please inform the Commission in writing as to which disposal well you utilized to dispose of the contents in the steel pits and the amount of fluid that was disposed. Please file form CDP-5, Exploration and Production Waste Transfer, within 30 days of fluid removal.

Should a haul-off pit be necessary please file form CDP-1, Application for Surface Pit, This location will have to be inspected prior to approval of the haul-off pit application.

A copy of this letter should be posted in the doghouse along with the approved Intent to Drill.