

KANSAS CORPORATION COMMISSION
OIL & GAS CONSERVATION DIVISION

TEMPORARY ABANDONMENT WELL APPLICATION

OPERATOR: License# _____
 Name: _____
 Address 1: _____
 Address 2: _____
 City: _____ State: _____ Zip: _____ + _____
 Contact Person: _____
 Phone: (_____) _____
 Contact Person Email: _____
 Field Contact Person: _____
 Field Contact Person Phone: (_____) _____

API No. 15- _____
 Spot Description: _____
 _____ - _____ - _____ - _____ Sec. _____ Twp. _____ S. R. _____ E W
 _____ feet from N / S Line of Section
 _____ feet from E / W Line of Section
 GPS Location: Lat: _____, Long: _____
(e.g. xx.xxxxx) (e.g. -xxx.xxxxx)
 Datum: NAD27 NAD83 WGS84
 County: _____ Elevation: _____ GL KB
 Lease Name: _____ Well #: _____
 Well Type: (check one) Oil Gas OG WSW Other: _____
 SWD Permit #: _____ ENHR Permit #: _____
 Gas Storage Permit #: _____
 Spud Date: _____ Date Shut-In: _____

	Conductor	Surface	Production	Intermediate	Liner	Tubing
Size						
Setting Depth						
Amount of Cement						
Top of Cement						
Bottom of Cement						

Casing Fluid Level from Surface: _____ How Determined? _____ Date: _____
 Casing Squeeze(s): _____ to _____ w / _____ sacks of cement, _____ to _____ w / _____ sacks of cement. Date: _____
(top) (bottom) (top) (bottom)
 Do you have a valid Oil & Gas Lease? Yes No
 Depth and Type: Junk in Hole at _____ Tools in Hole at _____ Casing Leaks: Yes No Depth of casing leak(s): _____
(depth) (depth)
 Type Completion: ALT. I ALT. II Depth of: DV Tool: _____ w / _____ sacks of cement Port Collar: _____ w / _____ sack of cement
(depth) (depth)
 Packer Type: _____ Size: _____ Inch Set at: _____ Feet
 Total Depth: _____ Plug Back Depth: _____ Plug Back Method: _____

Geological Data:

Formation Name	Formation Top	Formation Base	Completion Information
1. _____	At: _____	to _____ Feet	Perforation Interval _____ to _____ Feet or Open Hole Interval _____ to _____ Feet
2. _____	At: _____	to _____ Feet	Perforation Interval _____ to _____ Feet or Open Hole Interval _____ to _____ Feet

UNDER PENALTY OF PERJURY I HEREBY ATTEST THAT THE INFORMATION CONTAINED HEREIN IS TRUE AND CORRECT TO THE BEST OF MY KNOWLEDGE

Submitted Electronically

Do NOT Write in This Space - KCC USE ONLY	Date Tested: _____	Results: _____	Date Plugged: _____	Date Repaired: _____	Date Put Back in Service: _____
	Review Completed by: _____ Comments: _____				
TA Approved: <input type="checkbox"/> Yes <input type="checkbox"/> Denied Date: _____					

Mail to the Appropriate KCC Conservation Office:

	KCC District Office #1 - 210 E. Frontview, Suite A, Dodge City, KS 67801	Phone 620.682.7933
	KCC District Office #2 - 3450 N. Rock Road, Building 600, Suite 601, Wichita, KS 67226	Phone 316.337.7400
	KCC District Office #3 - 137 E. 21st St., Chanute, KS 66720	Phone 620.902.6450
	KCC District Office #4 - 2301 E. 13th Street, Hays, KS 67601-2651	Phone 785.261.6250

Liquid Level **2715 ft MD**

Fluid Above Pump **245 ft TVD**
Equivalent Gas Free Above Pump **244 ft TVD**

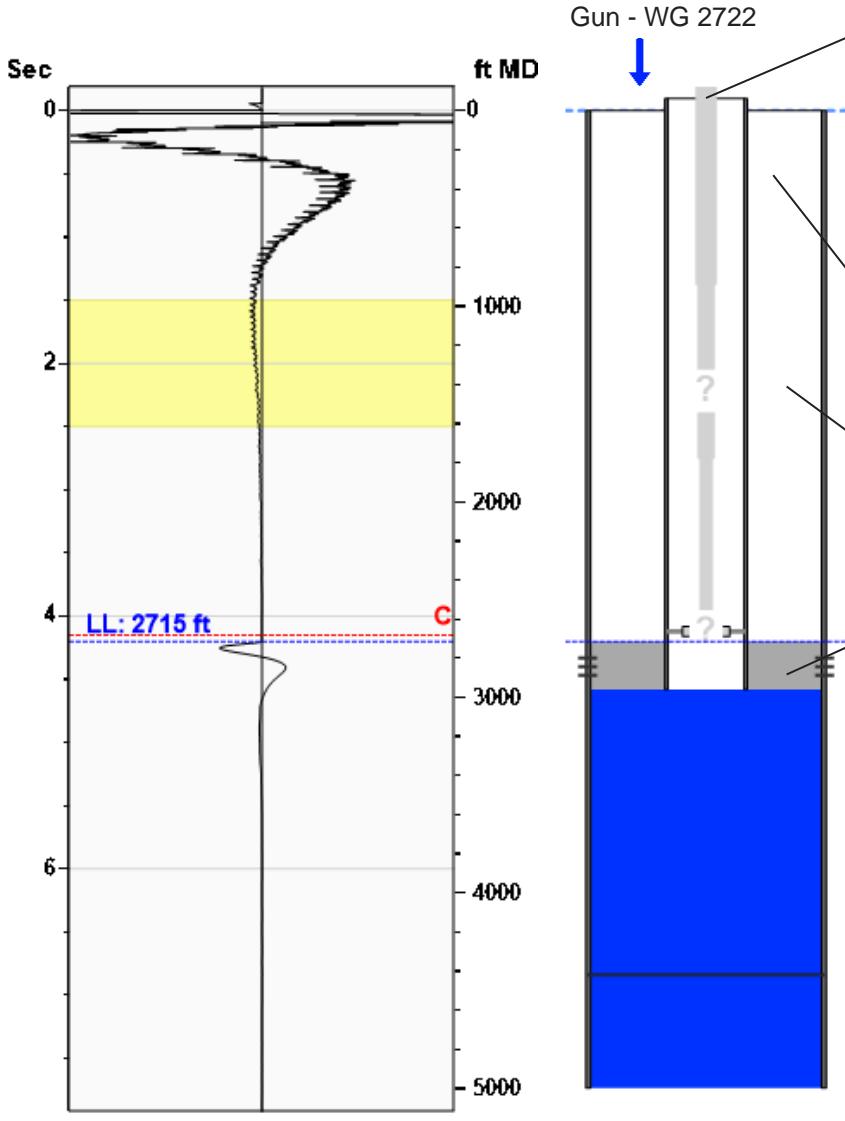

Production			
Date Entered	04/23/24		
	Current	Potential	
Oil	**	**	BBL/D
Water	**	**	BBL/D
Gas	**	**	Mscf/D
IPR Method	Vogel		
PBHP/SBHP	-0.00		
Producing Efficiency	0.00%		

Casing Pressure	
Pressure	0.5 psi (g)

Annular Gas Flow	
Gas Flow	0.6 Mscf/D

Fluid Properties	
% Liquid Above Pump	99.36%
% Liquid Below Pump	**

Depths	
Pump Intake Depth	2960 ft
Formation Depth	2922 ft

Wellbore Pressures	
PIP	84.0 psi (g)
PBHP	71.2 psi (g)
SBHP	**
Gas/Liq Interface	1.5 psi (g)

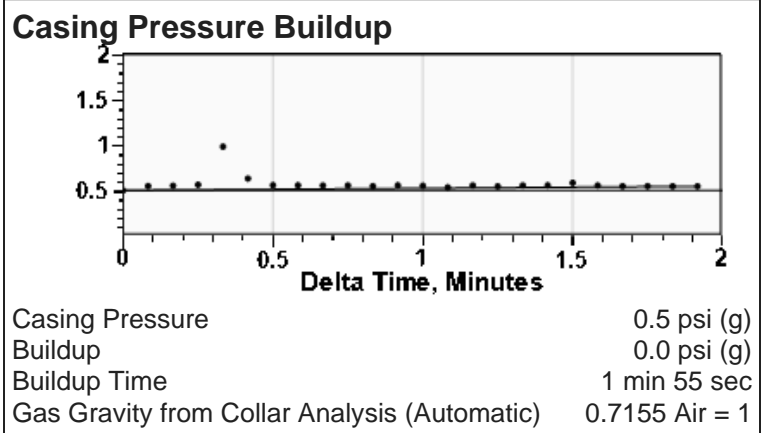
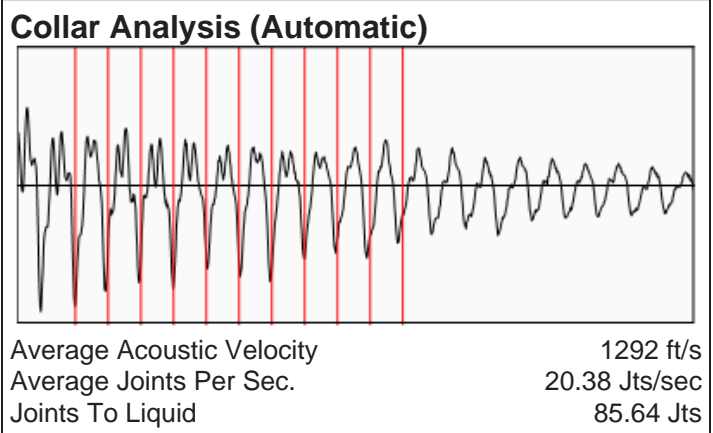

Comments and Recommendations

Echometer Company
 5001 Ditto Lane
 Wichita Falls, TX 76302
 (940) 767-4334
 info@echometer.com

Conservation Division
District Office No. 1
210 E. Frontview, Suite A
Dodge City, KS 67801



Phone: 620-682-7933
<http://kcc.ks.gov/>

Andrew J. French, Chairperson
Dwight D. Keen, Commissioner
Annie Kuether, Commissioner

Laura Kelly, Governor

05/14/2024

Lisa Jones
Pantera Energy Company
817 S POLK ST STE 201
AMARILLO, TX 79101-3433

Re: Temporary Abandonment
API 15-055-20841-00-02
ANDERSON 2-15
NW/4 Sec.15-24S-33W
Finney County, Kansas

Dear Lisa Jones:

"Your temporary abandonment (TA) application for the well listed above has been approved. In accordance with K.A.R. 82-3-111 the TA status of this well will expire 05/14/2025.

- * If you return this well to service or plug it, please notify the District Office.
- * If you sell this well you are required to file a Transfer of Operator form, T-1.
- * If the well will remain temporarily abandoned, you must submit a new TA application, CP-111, before 05/14/2025.

You may contact me at the number above if you have questions.

Very truly yours,

Michael Maier"