

RECEIVED

APR 12 2004

KCC WICHITA

KANSAS CORPORATION COMMISSION
OIL & GAS CONSERVATION DIVISION

WELL PLUGGING APPLICATION

Please TYPE Form and File ONE Copy

Form CP-1
September 2003
Form must be Typed
Form must be Signed
All blanks must be Filled

API # 15- 187-00350-0000 (Identifier Number of this well). This must be listed for wells drilled since 1967; if no API # was issued.

Indicate original spud or completion date 04/17/57

Well Operator: BP AMERICA PRODUCTION COMPANY KCC License #: 5952

Address: P. O. BOX 3092, WL1, RM 3.201 City: HOUSTON

State: TEXAS Zip Code: 77253-3092 Contact Phone: 281 366-2052

Lease: HEITZMAN GAS UNIT Well #: 2 Sec. 36 Twp. 28S R. 40 East West

Spot Location/QQQQ County STANTON

3947 S
1320 S
2673 F
50 W

SE NE NW SW SW SW SW
Q3 KCC Well GPS 'D . 8-18-04

Feet from (in exact footage) North / South (from nearest outside section corner) Line of Section (not Lease Line)

Feet from (in exact footage) East / West (from nearest outside section corner) Line of Section (not Lease Line)

Check One: Oil Well Gas Well D&A Cathodic Water Supply Well
 SWD Docket # _____ ENHR Docket # _____ Other _____

Conductor Casing Size: N/A Set at: _____ Cemented with: _____ Sacks

Surface Casing Size: 8 5/8" Set at: 686' Cemented with: 400 SXS Sacks

Production Casing Size: 5 1/2" Set at: 2410' Cemented with: 600 SXS Sacks

List (ALL) Perforations and Bridgeplug Sets: 2283-2295', 2311-2348', 2378-2388'

Elevation: 3238' (G.L. K.B.) T.D. 2410' PBDT 2398' Anhydrite Depth _____
(Stone Corral Formation)

Condition of Well: Good Poor Casing Leak Junk in Hole

Proposed Method of Plugging (attach a separate page if additional space is needed): SEE ATTACHED PROCEDURES

Is Well Log attached to this application as required? Yes No Is ACO-1 filed? Yes No

If not explain why? _____

Plugging of this Well will be done in accordance with K.S.A. 55-101 et. seq. and the Rules and Regulations of the State Corporation Commission

List Name of Company Representative authorized to be in charge of plugging operations:

SUE SELLERS Phone: 281 366-2052

Address: P. O. BOX 3092, WL 1, RM 3.201 City/State HOUSTON, TEXAS 77253-3092

Plugging Contractor HALLIBURTON SERVICES KCC License # 99997
(Company Name) (Contractor's)

Address _____ Phone: _____

Proposed Date and Hour of Plugging (if known?): _____

Payment of the Plugging Fee (K.A.R. 82-3-118) will be guaranteed by Operator or Agent

Date: 04/07/04 Authorized Operator / Agent: Sue Sellers
(Signature)

Plugging Application
Heitzman 2 – Abandonment
Section 36, T28S, R40W
Stanton County, Kansas

The application attached is to abandon the Heitzman 2. BP America Production Company is abandoning this well since it is uneconomic to operate. It is doubtful that commercial production can be restored from the well.

RECEIVED
APR 12 2004
KCC WICHITA

**Plugging Procedure for the Heitzman 2
Section 36 T28S R40W
Stanton County, Kansas**

NOTE – NOTIFY KCC DISTRICT OFFICE AT LEAST FIVE DAYS IN ADVANCE OF WORK.

This procedure was approved via a telephone conversation between Brent Nickel (BP representative) and Jim Holland (KCC) on March 11, 2004.

Procedure:

1. Pump 75 sks 60/40 POZ cement w/ 6% gel mixed @13.1 #/gal down 5 1/2" csg w/ 7 sks of cottonseed hulls added to slurry.
2. Pump 270 sks 60/40 POZ cement w/ 6% gel mixed @ 13.1 #/gal. down 5 1/2" csg or until 500 psi is reached.
3. Pump 50 sks 60/40 POZ cement w/ 6% gel mixed @ 13.1 #/gal. down 8 5/8" X 5 1/2" annulus. or until 500 psi is reached.
4. Cut csg off at 5' below ground level. Cap csg.
5. Restore location.

Cement Information:

Class "H" 60/40 poz with 6% gel mixed at 13.2 lb/gal with a yield of 1.53 cu. ft./ sk

RECEIVED
APR 12 2004
KCC WICHITA

Heitzman 2
Section 36, T28S, R40W
Chase Gas Field
Stanton County, Kansas

RECEIVED
APR 12 2004
KCC WICHITA

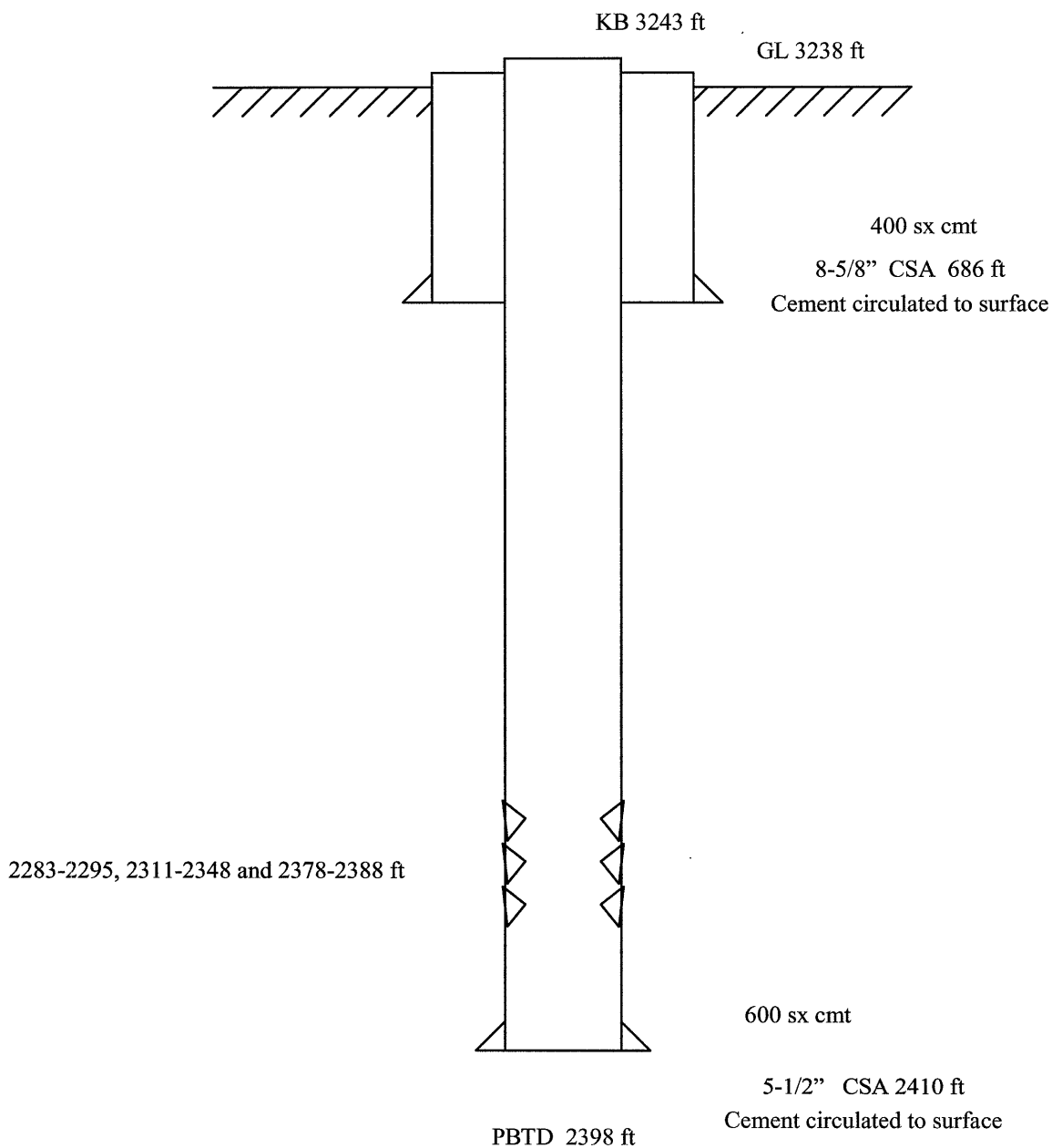

Not to scale

RECEIVED
APR 12 2004
KCC WICHITA

Heitzman 2
Section 36, T28S, R40W
Chase Gas Field
Stanton County, Kansas

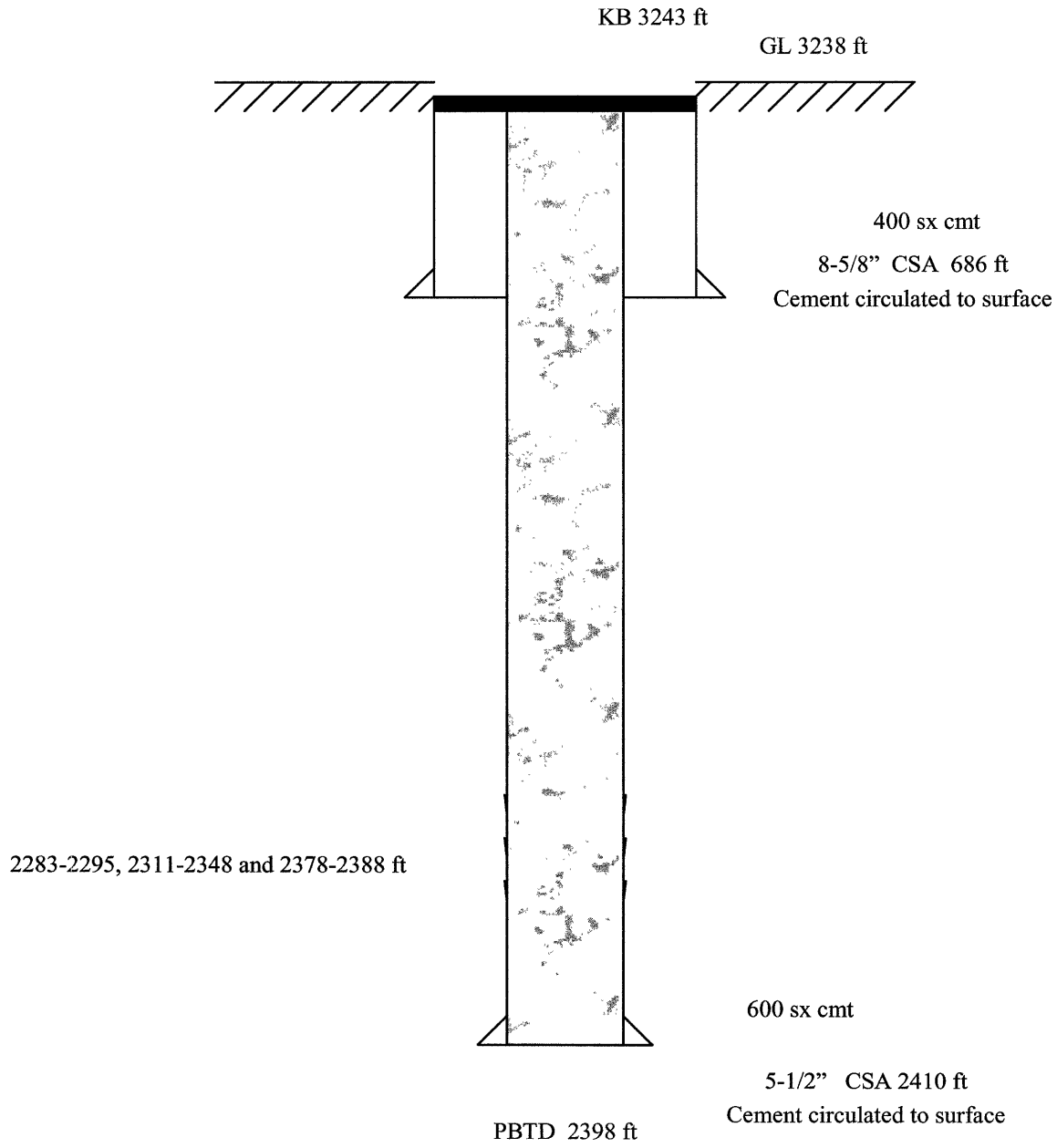

Not to scale

KANSAS

CORPORATION COMMISSION

Kathleen Sebelius, Governor Brian J. Moline, Chair John Wine, Commissioner Robert E. Krehbiel, Commissioner

NOTICE OF RECEIPT OF WELL PLUGGING APPLICATION (CP-1)

BP America Production Company
2225 West Oklahoma Avenue
Ulysses, KS 67880

April 19, 2004

Re: HEITZMAN GAS UNIT #2
API 15-187-00350-00-00

3997S 2673E KCC
apb.

SESENLW ~~NWNWSWSW-36-28S-40W, 1320 FSL 50 FWL~~
STANTON COUNTY, KANSAS

Dear Operator:

This letter is to notify you that the Conservation Division is in receipt of your plugging proposal, form CP-1, for the above-captioned well.

Your CP-1 has been reviewed by the Conservation Division central office for completeness and to verify license numbers. The plugging proposal will now be forwarded to the district office listed below for review of your proposed method of plugging.

Please contact the district office for approval of your proposed plugging method at least five (5) days before plugging the well, pursuant to K.A.R. 82-3-113 (b). If a workover pit will be used during the plugging of the well it must be permitted. A CDP-1 form must be filed and approved prior to the use of the pit.

The Conservation Division's review of form CP-1, either in the central or district office, does not include an inquiry into well ownership or the filing operator's legal right to plug the well.

This notice in no way constitutes authorization to plug the above-captioned well by persons not having legal rights of ownership or interest in the well. This notice is void after ninety (90) days from the above date.

District: #1
210 E Frontview, Suite A
Dodge City, KS 67801
(620) 225-8888

Sincerely



David P. Williams
Production Supervisor