

For KCC Use: Effective Date: 11-14-04  
District #: 1  
SGA?  Yes  No

KANSAS CORPORATION COMMISSION  
OIL & GAS CONSERVATION DIVISION

Form C-1  
December 2002  
Form must be Typed  
Form must be Signed  
All blanks must be Filled

NOTICE OF INTENT TO DRILL

Must be approved by KCC five (5) days prior to commencing well

Expected Spud Date January 20 2005  
month day year

Spot:  East  West  
Sec. 26 Twp. 22 S. R. 33  
NW SW NW  
1600 feet from  N /  S Line of Section  
330 feet from  E /  W Line of Section

OPERATOR: License# 4058  
Name: American Warrior, Inc  
Address: PO Box 399  
City/State/Zip: Garden City, KS 67846  
Contact Person: Cecil O'Brate  
Phone: 620-275-9231

Is SECTION  Regular  Irregular?  
(Note: Locate well on the Section Plat on reverse side)  
County: Finney

CONTRACTOR: License# 33375  
Name: Cheyenne Drilling, LP

Lease Name: Damme Well #: 1-26  
Field Name: Damme

Is this a Prorated / Spaced Field?  Yes  No  
Target Information(s): Mississippi

Well Drilled For: Well Class: Type Equipment:  
 Oil  Enh Rec  Infield  Mud Rotary  
 Gas  Storage  Pool Ext.  Air Rotary  
 OWD  Disposal  Wildcat  Cable  
 Seismic; # of Holes  Other  
 Other

Nearest Lease or unit boundary: 330  
Ground Surface Elevation: 2785 feet MSL

Water well within one-quarter mile:  Yes  No  
Public water supply well within one mile:  Yes  No

Depth to bottom of fresh water: 240 / 280  
Depth to bottom of usable water: 1090

Surface Pipe by Alternate:  1  2  
Length of Surface Pipe Planned to be set: 1700'

Length of Conductor Pipe required: N/A NONE  
Projected Total Depth: 4900

Formation at Total Depth: Mississippi  
Water Source for Drilling Operations:  
 Well  Farm Pond Other \_\_\_\_\_

DWR Permit #: \_\_\_\_\_  
(Note: Apply for Permit with DWR )

Will Cores be taken?  Yes  No  
If Yes, proposed zone: \_\_\_\_\_

If OWWO: old well information as follows:  
Operator: \_\_\_\_\_  
Well Name: \_\_\_\_\_  
Original Completion Date: \_\_\_\_\_ Original Total Depth: \_\_\_\_\_

Directional, Deviated or Horizontal wellbore?  Yes  No  
If Yes, true vertical depth: \_\_\_\_\_

Bottom Hole Location: \_\_\_\_\_  
KCC DKT #: \_\_\_\_\_

Prorated & Spaced Hugobon

AFFIDAVIT

The undersigned hereby affirms that the drilling, completion and eventual plugging of this well will comply with K.S.A. 55 et. seq.  
It is agreed that the following minimum requirements will be met:

1. Notify the appropriate district office **prior** to spudding of well;
2. A copy of the approved notice of intent to drill **shall be posted** on each drilling rig;
3. The minimum amount of surface pipe as specified below **shall be set** by circulating cement to the top; in all cases surface pipe **shall be set** through all unconsolidated materials plus a minimum of 20 feet into the underlying formation.
4. If the well is dry hole, an agreement between the operator and the district office on plug length and placement is necessary **prior to plugging**;
5. The appropriate district office will be notified before well is either plugged or production casing is cemented in;
6. If an ALTERNATE II COMPLETION, production pipe shall be cemented from below any usable water to surface within **120 days** of spud date.  
Or pursuant to Appendix "B" - Eastern Kansas surface casing order #133,891-C, which applies to the KCC District 3 area, alternate II cementing must be completed within 30 days of the spud date or the well shall be plugged. **In all cases, NOTIFY district office** prior to any cementing.

I hereby certify that the statements made herein are true and to the best of my knowledge and belief.

Date: 11-14-04 Signature of Operator or Agent: Wray Vahlf Title: Agent

Remember to:

- File Drill Pit Application (form CDP-1) with Intent to Drill;
- File Completion Form ACO-1 within 120 days of spud date;
- File acreage attribution plat according to field proration orders;
- Notify appropriate district office 48 hours prior to workover or re-entry;
- Submit plugging report (CP-4) after plugging is completed;
- Obtain written approval before disposing or injecting salt water.
- If this permit has expired (See: authorized expiration date) please check the box below and return to the address below.

Well Not Drilled - Permit Expired

Signature of Operator or Agent: \_\_\_\_\_  
Date: \_\_\_\_\_

For KCC Use ONLY

API # 15 - 055-21847-00-00  
Conductor pipe required NONE feet  
Minimum surface pipe required 1120 feet per Alt. 1  
Approved by: RJP 11-9-04  
This authorization expires: 5-9-05  
(This authorization void if drilling not started within 6 months of effective date.)  
Spud date: \_\_\_\_\_ Agent: \_\_\_\_\_

Mail to: KCC - Conservation Division, 130 S. Market - Room 2078, Wichita, Kansas 67202

26 22 334

**IN ALL CASES PLOT THE INTENDED WELL ON THE PLAT BELOW**

*Plat of acreage attributable to a well in a prorated or spaced field*

*If the intended well is in a prorated or spaced field, please fully complete this side of the form. If the intended well is in a prorated or spaced field complete the plat below showing that the well will be properly located in relationship to other wells producing from the common source of supply. Please show all the wells and within 1 mile of the boundaries of the proposed acreage attribution unit for gas wells and within 1/2 mile of the boundaries of the proposed acreage attribution unit for oil wells.*

API No. 15 - \_\_\_\_\_  
 Operator: American Warrior, Inc.  
 Lease: Damme  
 Well Number: 1-26  
 Field: Damme  
 Number of Acres attributable to well: 160  
 QTR / QTR / QTR of acreage: \_\_\_\_\_ - \_\_\_\_\_ - NW/4

Location of Well: County: Finney  
 \_\_\_\_\_ 1600 feet from  N /  S Line of Section  
 \_\_\_\_\_ 330 feet from  E /  W Line of Section  
 Sec. 26 Twp. 22 S. R. 33  East  West

Is Section:  Regular or  Irregular

**If Section is Irregular, locate well from nearest corner boundary.**

Section corner used:  NE  NW  SE  SW

**PLAT**

*(Show location of the well and shade attributable acreage for prorated or spaced wells.)*

*(Show footage to the nearest lease or unit boundary line.)*

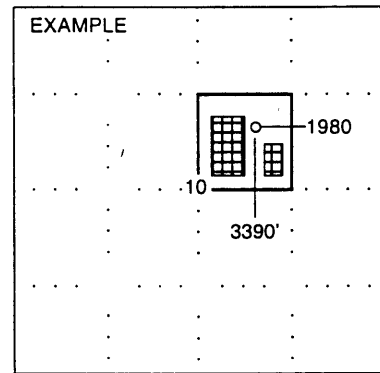
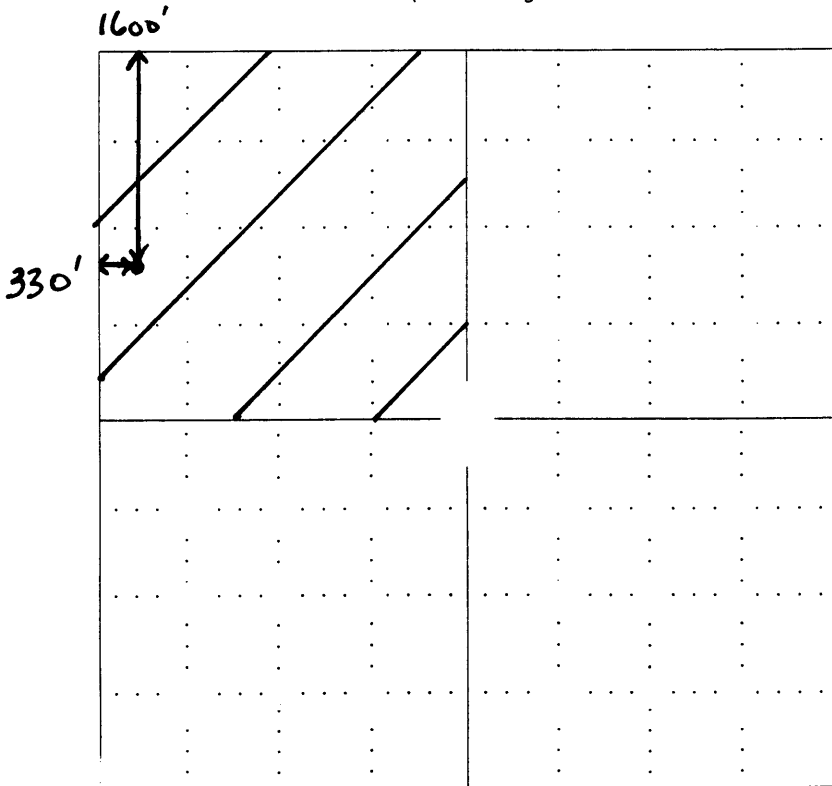

**NOTE: In all cases locate the spot of the proposed drilling locaton.**

**In plotting the proposed location of the well, you must show:**

1. The manner in which you are using the depicted plat by identifying section lines, i.e. 1 section, 1 section with 8 surrounding sections, 4 sections, etc.
2. The distance of the proposed drilling location from the section's south / north and east / west.
3. The distance to the nearest lease or unit boundary line.
4. If proposed location is located within a prorated or spaced field a certificate of acreage attribution plat must be attached: (CO-7 for oil wells; CG-8 for gas wells).