

APR 15 2005

CONSERVATION DIVISION
WICHITA, KS

WELL PLUGGING APPLICATION FORM
(PLEASE TYPE FORM and File ONE Copy)

API # 15-055-00769-00-00 (Identifier number of this well). This must be listed for wells drilled since 1967; if no API# was issued, indicate spud or completion date.

WELL OPERATOR BP America Production Company KCC LICENSE # 5952
(owner/company name) (operator's)

ADDRESS P.O. Box 3092 Room 3.201 CITY Houston

STATE TX ZIP CODE 77253 CONTACT PHONE # (281) 366-7816

LEASE GEARhart GAS Unit WELL# 1 SEC. 20 T. 23S R. 32W (East/West)

SW - SW - SW - NE SPOT LOCATION/QQQQ COUNTY FINNEY

2490 FEET (in exact footage) FROM S/(N) (circle one) LINE OF SECTION (NOT Lease Line)

2590 FEET (in exact footage) FROM (E)W (circle one) LINE OF SECTION (NOT Lease Line)

Check One: OIL WELL GAS WELL D&A SWD/ENHR WELL DOCKET# _____

CONDUCTOR CASING SIZE _____ SET AT _____ CEMENTED WITH _____ SACKS

SURFACE CASING SIZE 8 5/8 SET AT 963 CEMENTED WITH _____ SACKS

PRODUCTION CASING SIZE 5 1/2 SET AT 2573 CEMENTED WITH _____ SACKS

LIST (ALL) PERFORATIONS and BRIDGEPLUG SETS: 2526-2566

ELEVATION 2848 T.D. 2576 PBTD _____ ANHYDRITE DEPTH _____
(G.L./K.B.) (Stone Corral Formation)

CONDITION OF WELL: GOOD POOR CASING LEAK JUNK IN HOLE

PROPOSED METHOD OF PLUGGING SEE Attached procedure

(If additional space is needed attach separate page)

IS WELL LOG ATTACHED TO THIS APPLICATION AS REQUIRED? IS ACO-1 FILED? Yes
If not explain why? (#2 HI OFFSET WELL log attached)

PLUGGING OF THIS WELL WILL BE DONE IN ACCORDANCE WITH K.S.A. 55-101 et. seq. AND THE RULES AND REGULATIONS OF THE STATE CORPORATION COMMISSION.

LIST NAME OF COMPANY REPRESENTATIVE AUTHORIZED TO BE IN CHARGE OF PLUGGING OPERATIONS:

JOE Eudey PHONE# (620) 356-6981

ADDRESS 2225 West Oklahoma City/State Ulysses, KS 67880

PLUGGING CONTRACTOR Halliburton Services KCC LICENSE # 5287 99997
(company name) (contractor's)

ADDRESS _____ PHONE # () _____

PROPOSED DATE AND HOUR OF PLUGGING (If Known?) _____

PAYMENT OF THE PLUGGING FEE (K.A.R. 82-3-118) WILL BE GUARANTEED BY OPERATOR OR AGENT

DATE: 4/13/05 AUTHORIZED OPERATOR/AGENT: Lou Barry
(signature)

15-055-00769-00-00

RECEIVED
KANSAS CORPORATION COMMISSION

APR 15 2005

CONSERVATION DIVISION
WICHITA, KS

Plugging Application
Gearhart 1 Abandonment
Sec 20, T23S, R32W
Finney County, Kansas

BP America Production Company

The application attached is to abandon the Gearhart 1. ~~BP Amoco~~ is abandoning this well as it has become uneconomic to operate.

RECEIVED
KANSAS CORPORATION COMMISSION

APR 15 2005

CONSERVATION DIVISION
WICHITA, KS

Plugging Procedure for the Gearhart 1
Section 20 T23S R32W
Finney County, Kansas

NOTE – NOTIFY KCC DISTRICT OFFICE AT LEAST FIVE DAYS IN ADVANCE OF WORK.

This procedure was approved via a telephone conversation between Joe Eudey (BP representative) and Mike Maier (KCC) on April 11, 2005.

PROPOSED PROCEDURE:

1. Mix and pump 300 sacks of cement, with 500# of cottonseed hulls in the lead slurry, to fill the 5.5" casing from 0' to 2566'.
2. Have 50 extra sacks of cement to fill the annulus between the 8.625" casing and the 5.5" casing, if needed.
3. Cut off and cap the casing 5' below ground level.
4. Restore the location.

CEMENT INFORMATION

60/40 class C premium plus w/6% gel
Cement to be mixed at 12.3 ppg, yield 1.53 cuft/sx.

RECEIVED
KANSAS CORPORATION COMMISSION

APR 15 2005

CONSERVATION DIVISION
WICHITA, KS

Gearhart 1
Section 20, T23S, R32W
Chase Formation
Hugoton Field
Finney County, Kansas

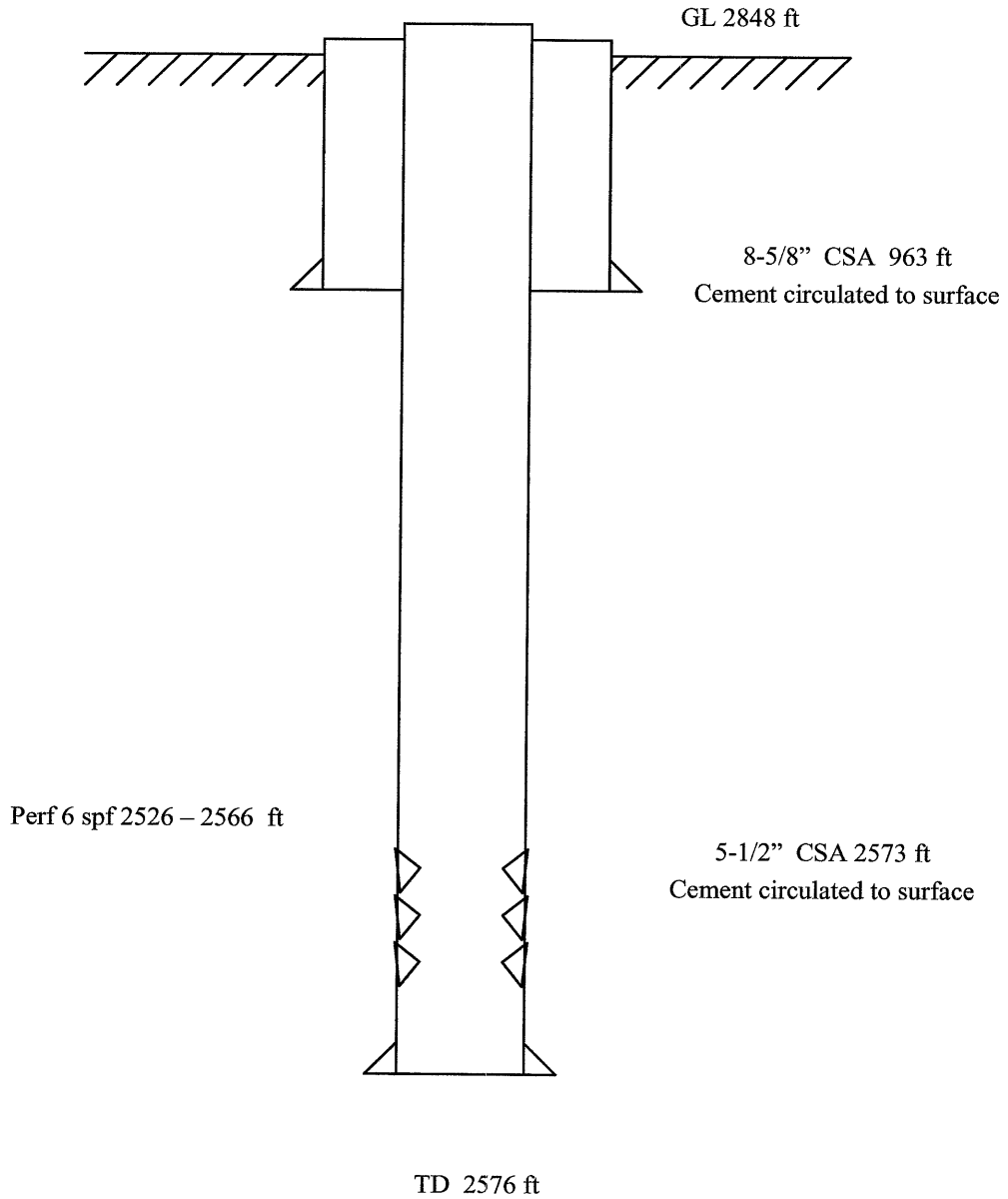

Not to scale

RECEIVED
KANSAS CORPORATION COMMISSION

APR 15 2005

CONSERVATION DIVISION
WICHITA, KS

Gearhart 1
Section 20, T23S, R32W
Chase Formation
Hugoton Field
Finney County, Kansas

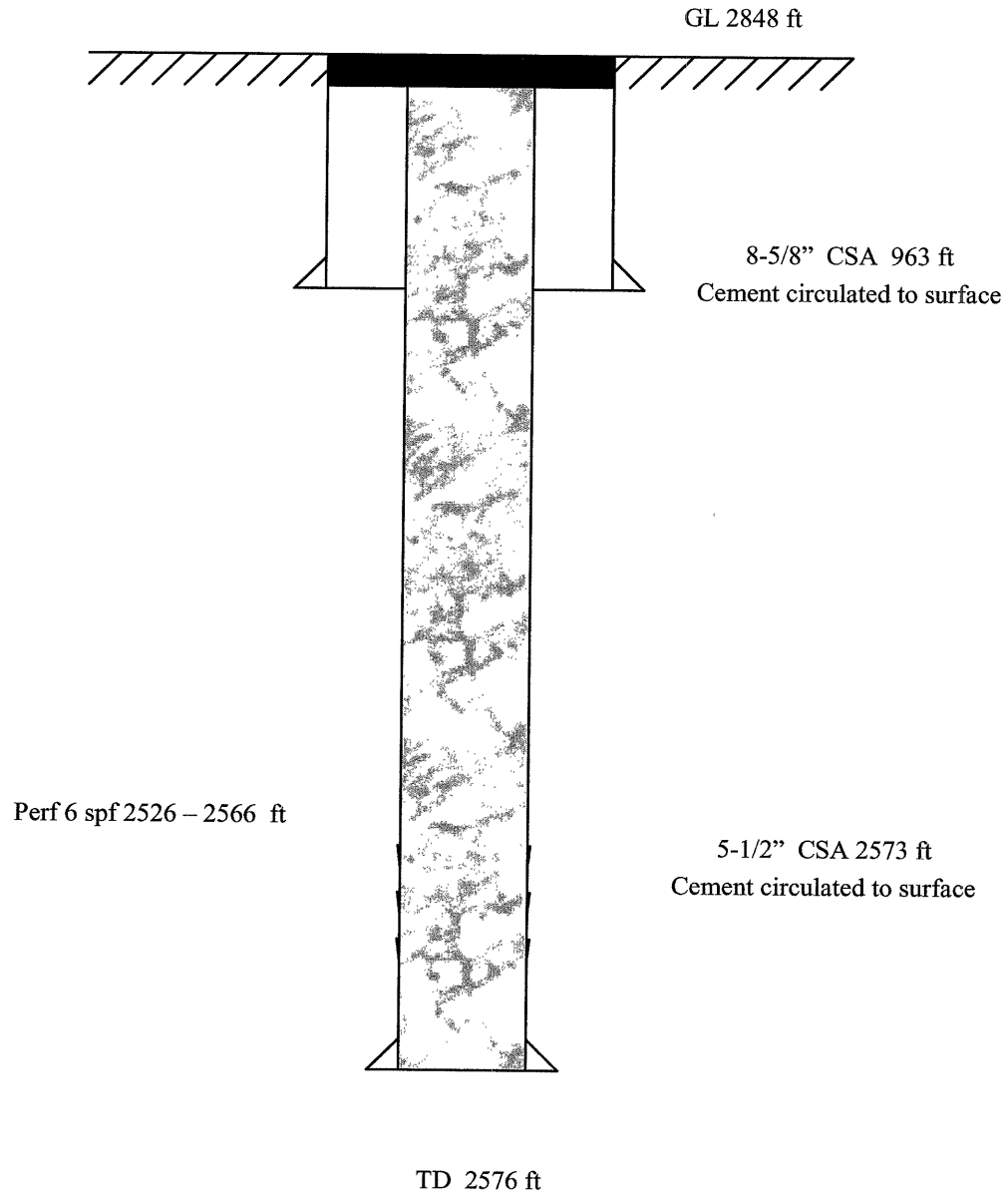

Not to scale



KANSAS

CORPORATION COMMISSION

Kathleen Sebelius, Governor Brian J. Moline, Chair Robert E. Krehbiel, Commissioner Michael C. Moffet, Commissioner

NOTICE OF RECEIPT OF WELL PLUGGING APPLICATION (CP-1)

BP America Production Company
2225 West Oklahoma Avenue
Ulysses, KS 67880

April 18, 2005

Re: GEARHART #1
API 15-055-00769-00-00
SWSWSWNE 20-23S-32W, 2490 FNL 2590 FEL
FINNEY COUNTY, KANSAS

Dear Operator:

This letter is to notify you that the Conservation Division is in receipt of your plugging proposal, form CP-1, for the above-captioned well.

Your CP-1 has been reviewed by the Conservation Division central office for completeness and to verify license numbers. The plugging proposal will now be forwarded to the district office listed below for review of your proposed method of plugging.

Please contact the district office for approval of your proposed plugging method at least five (5) days before plugging the well, pursuant to K.A.R. 82-3-113 (b). If a workover pit will be used during the plugging of the well it must be permitted. A CDP-1 form must be filed and approved prior to the use of the pit.

The Conservation Division's review of form CP-1, either in the central or district office, does not include an inquiry into well ownership or the filing operator's legal right to plug the well.

This notice in no way constitutes authorization to plug the above-captioned well by persons not having legal rights of ownership or interest in the well. This notice is void after ninety (90) days from the above date.

District: #1
210 E Frontview, Suite A
Dodge City, KS 67801
(620) 225-8888

Sincerely

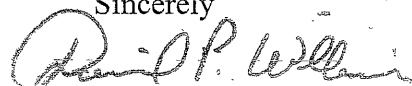

David P. Williams
Production Supervisor