

For KCC Use: 10-25-05
 Effective Date: 10-25-05
 District # 1
 SGA? Yes No

KANSAS CORPORATION COMMISSION
 OIL & GAS CONSERVATION DIVISION

Form C-1
 December 2002
 Form must be Typed
 Form must be Signed
 All blanks must be Filled

NOTICE OF INTENT TO DRILL

Must be approved by KCC five (5) days prior to commencing well

Expected Spud Date TBD - Fall/Winter 2005 - 10/25/05
 month day year

Spot E/2 SW SW Sec. 26 Twp. 25 S. R. 33 East West

OPERATOR: License# 5317
 Name: Russell Freeman d/b/a Continental Energy
 Address: P.O. Box 918
Garden City, KS 67846
 Contact Person: Russell Freeman
 Phone: (620) 276-8710

625 feet from N S Line of Section
1250 feet from E W Line of Section

Is SECTION Regular Irregular?
 (Note: Locate well on the Section Plat on reverse side)

CONTRACTOR: License# 33375
 Name: Cheyenne Drilling LP

County: Finney
 Lease Name: Kidd Well #: 1-26
 Field Name: Panoma

Is this a Prorated / Spaced Field? Yes No
 Target Formation(s): Council Grove

Well Drilled For:	Well Class:	Type Equipment:
<input type="checkbox"/> Oil	<input type="checkbox"/> Enh Rec	<input type="checkbox"/> Infield
<input checked="" type="checkbox"/> Gas	<input type="checkbox"/> Storage	<input checked="" type="checkbox"/> Mud Rotary
<input type="checkbox"/> OWWO	<input type="checkbox"/> Disposal	<input type="checkbox"/> Air Rotary
<input type="checkbox"/> Seismic; # of Holes	<input type="checkbox"/> Other	<input type="checkbox"/> Cable
<input type="checkbox"/> Other		

* Nearest Lease or unit boundary: 1250'
 Ground Surface Elevation: awaiting surveying/staking 2904 feet MSL

Water well within one-quarter mile: Yes No
 Public water supply well within one mile: Yes No

Depth to bottom of fresh water: 580' 560
 Depth to bottom of usable water: 600' 940

Surface Pipe by Alternate: 2 ALT-2 PER RUSSELL FREEMAN
 Length of Surface Pipe Planned to be set: 600' 10-25-05

If OWWO: old well information as follows:
 Operator: _____
 Well Name: _____
 Original Completion Date: _____ Original Total Depth: _____

Length of Conductor Pipe required: None
 Projected Total Depth: 3200'
 Formation at Total Depth: Council Grove

Directional, Deviated or Horizontal wellbore? Yes No
 If Yes, true vertical depth: _____

Water Source for Drilling Operations:
 Well Farm Pond Other Trucked

Bottom Hole Location: _____
 KCC DKT #: _____

DWR Permit #: _____
 (Note: Apply for Permit with DWR)

* Unit extends to NW/4 35. 25-33W

Will Cores be taken? Yes No
 If Yes, proposed zone: _____

AFFIDAVIT

The undersigned hereby affirms that the drilling, completion and eventual plugging of this well will comply with K.S.A. 55 et. seq.
 It is agreed that the following minimum requirements will be met:

RECEIVED
 OCT 07 2005
 KCC WICHITA

1. Notify the appropriate district office *prior* to spudding of well;
2. A copy of the approved notice of intent to drill *shall be* posted on each drilling rig;
3. The minimum amount of surface pipe as specified below *shall be set* by circulating cement to the top; in all cases surface pipe *shall be set* through all unconsolidated materials plus a minimum of 20 feet into the underlying formation.
4. If the well is dry hole, an agreement between the operator and the district office on plug length and placement is necessary *prior to plugging*;
5. The appropriate district office will be notified before well is either plugged or production casing is cemented in;
6. If an ALTERNATE II COMPLETION, production pipe shall be cemented from below any usable water to surface within **120 days** of spud date.
 Or pursuant to Appendix "B" - Eastern Kansas surface casing order #133,891-C, which applies to the KCC District 3 area, alternate II cementing must be completed within 30 days of the spud date or the well shall be plugged. **In all cases, NOTIFY district office** prior to any cementing.

I hereby certify that the statements made herein are true and to the best of my knowledge and belief.

Date: Oct 6, 2005 Signature of Operator or Agent: Russell Freeman Title: Owner

For KCC Use ONLY
 API # 15 - 055-21891-00-00
 Conductor pipe required NONE feet
 Minimum surface pipe required 580 feet per Alt. * (2)
 Approved by RJP 10-20-05
 This authorization expires: 4-20-06
 (This authorization void if drilling not started within 6 months of effective date.)
 Spud date: _____ Agent: _____

- Remember to:**
- File Drill Pit Application (form CDP-1) with Intent to Drill;
 - File Completion Form ACO-1 within 120 days of spud date;
 - File acreage attribution plat according to field proration orders;
 - Notify appropriate district office 48 hours prior to workover or re-entry;
 - Submit plugging report (CP-4) after plugging is completed;
 - Obtain written approval before disposing or injecting salt water.
- If this permit has expired (See: authorized expiration date) please check the box below and return to the address below.
 Well Not Drilled - Permit Expired
 Signature of Operator or Agent: _____
 Date: _____

26 25 33W

IN ALL CASES PLOT THE INTENDED WELL ON THE PLAT BELOW

Plat of acreage attributable to a well in a prorated or spaced field

If the intended well is in a prorated or spaced field, please fully complete this side of the form. If the intended well is in a prorated or spaced field complete the plat below showing that the well will be properly located in relationship to other wells producing from the common source of supply. Please show all the wells and within 1 mile of the boundaries of the proposed acreage attribution unit for gas wells and within 1/2 mile of the boundaries of the proposed acreage attribution unit for oil wells.

API No. 15 - _____
 Operator: Russell Freeman d/b/a Continental Energy
 Lease: Kidd
 Well Number: 1-26
 Field: Panoma

Number of Acres attributable to well: 320
 QTR / QTR / QTR of acreage: E/2 - SW - SW

Location of Well: County: Finney
 _____ 625 feet from N / S Line of Section
 _____ 1250 feet from E / W Line of Section
 Sec. 26 Twp. 25 S. R. 33 East West

Is Section: Regular or Irregular

If Section is Irregular, locate well from nearest corner boundary.
 Section corner used: NE NW SE SW

PLAT

*(Show location of the well and shade attributable acreage for prorated or spaced wells.)
 (Show footage to the nearest lease or unit boundary line.)*

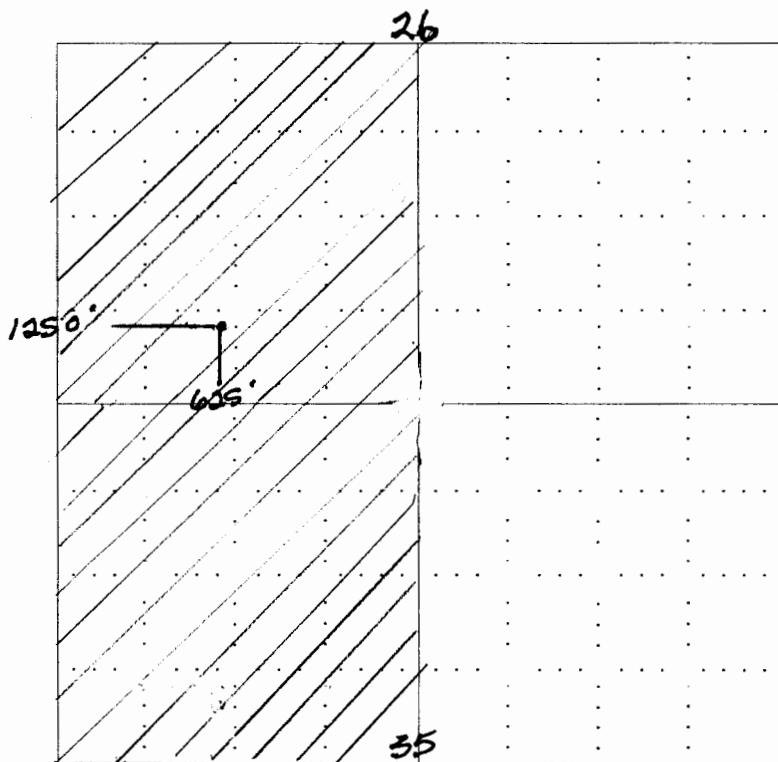

NOTE: In all cases locate the spot of the proposed drilling location.

RECEIVED
 OCT 07 2005

CC WICHITA

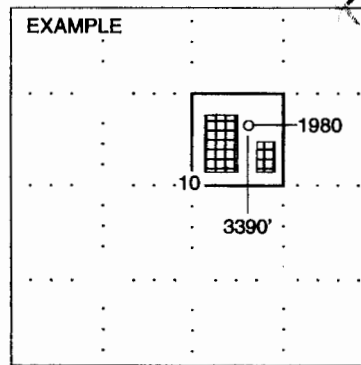

In plotting the proposed location of the well, you must show:

1. The manner in which you are using the depicted plat by identifying section lines, i.e. 1 section, 1 section with 8 surrounding sections, 4 sections, etc.
2. The distance of the proposed drilling location from the section's south / north and east / west.
3. The distance to the nearest lease or unit boundary line.
4. If proposed location is located within a prorated or spaced field a certificate of acreage attribution plat must be attached: (CO-7 for oil wells; CG-8 for gas wells).



KANSAS

CORPORATION COMMISSION

KATHLEEN SEBELIUS, GOVERNOR

BRIAN J. MOLINE, CHAIR

ROBERT E. KREHBIEL, COMMISSIONER

MICHAEL C. MOFFET, COMMISSIONER

NOTICE TO OPERATORS DRILLING IN THE PANOMA- COUNCIL GROVE GAS POOL SPACED AREA

The enclosed intent is located within the Panoma-Council Grove gas pool space area. In May 1978, Panoma-Council Grove Proration Order (as amended), Docket No. 60,024-C (C-7058) under FINDINGS OF FACT AND LAW on page 31, the following language is stated that:

“The Commission finds that in order to prevent waste and protect correlative rights, the following stated rules pertaining to wells already completed, in the process of being drilled or for future wells to be drilled in the Panoma Council Grove Gas Pool Spaced area, and for wells producing from the Council Grove Formation outside of the Panoma Council Grove Gas Pool Spaced area within the Hugoton Gas Field, should be adopted.”

1. “No dual completions between the Chase (Hugoton) and Council Grove Formations will be permitted for future wells drilled.”
2. “Casing shall not be set above the top of the Council Grove Formation for a Council Grove producing well.”
3. “The production casing of all new Council Grove wells should be cemented with a calculated volume of cement sufficient to encase the casing from the bottom of the casing to a point 500 feet above the Chase Formation.”
4. “The casing shall be encased in cement in the interval between the base of the Council Grove and the top of the Chase Formation on all wells, irrespective of depth, completed below the Council Grove Formation, if they are located within the space area.”
5. “The cement coverage heretofore required shall be confirmed by the running of a recognized survey, such as a temperature survey or cement bond log.”

A copy of this survey and the cement tickets(s) showing that all cement work has been completed, must be filed with the ACO-1 Completion Report within 120 days from the wells “spud date.”

Failure to comply with these provisions may cause the well to be shut-in until compliance has been achieved.

If you have any questions, please feel free to contact the Conservation Division’s Production Department at (316) 337-6200.