

For KCC Use: 12.18.05
Effective Date: _____
District # _____
SGA? Yes No

KANSAS CORPORATION COMMISSION
OIL & GAS CONSERVATION DIVISION

Form C-1
December 2002
Form must be Typed
Form must be Signed
All blanks must be Filled

NOTICE OF INTENT TO DRILL

Must be approved by KCC five (5) days prior to commencing well

Expected Spud Date 02 23 2006
month day year

OPERATOR: License# 4058
Name: American Warrior, Inc.
Address: P. O. Box 399
City/State/Zip: Garden City, KS 67846
Contact Person: Scott Corsair
Phone: 785-398-2270

CONTRACTOR: License# 33323
Name: Petromark Drilling, LLC

Well Drilled For:	Well Class:	Type Equipment:
<input checked="" type="checkbox"/> Oil	<input type="checkbox"/> Enh Rec	<input checked="" type="checkbox"/> Infield
<input checked="" type="checkbox"/> Gas	<input type="checkbox"/> Storage	<input type="checkbox"/> Pool Ext.
<input type="checkbox"/> OWO	<input type="checkbox"/> Disposal	<input type="checkbox"/> Wildcat
<input type="checkbox"/> Seismic; _____ # of Holes	<input type="checkbox"/> Other	<input type="checkbox"/> Cable
<input type="checkbox"/> Other		

If OWWO: old well information as follows:
Operator: _____
Well Name: _____
Original Completion Date: _____ Original Total Depth: _____

Directional, Deviated or Horizontal wellbore? Yes No
If Yes, true vertical depth: _____
Bottom Hole Location: _____
KCC DKT #: _____

Spot East West
SW - SW - NE Sec. 19 Twp. 19 S. R. 21
2310 feet from N / S Line of Section
2310 feet from E / W Line of Section
Is SECTION Regular Irregular?

(Note: Locate well on the Section Plat on reverse side)
County: Ness
Lease Name: Wittman Well #: 9
Field Name: Schaben
Is this a Prorated / Spaced Field? Yes No
Target Formation(s): Mississippian
Nearest Lease or unit boundary: 330'
Ground Surface Elevation: 2290 feet MSL
Water well within one-quarter mile: Yes No
Public water supply well within one mile: Yes No
Depth to bottom of fresh water: (480') 180'
Depth to bottom of usable water: 720' 750'
Surface Pipe by Alternate: 1 2
Length of Surface Pipe Planned to be set: 200
Length of Conductor Pipe required: None
Projected Total Depth: 4400'
Formation at Total Depth: Mississippian
Water Source for Drilling Operations:
 Well Farm Pond Other _____
DWR Permit #: _____
(Note: Apply for Permit with DWR)
Will Cores be taken? Yes No
If Yes, proposed zone: _____

AFFIDAVIT

The undersigned hereby affirms that the drilling, completion and eventual plugging of this well will comply with K.S.A. 55 et. seq.
It is agreed that the following minimum requirements will be met:
1. Notify the appropriate district office **prior** to spudding of well;
2. A copy of the approved notice of intent to drill **shall be** posted on each drilling rig;
3. The minimum amount of surface pipe as specified below **shall be set** by circulating cement to the top; in all cases surface pipe **shall be set** through all unconsolidated materials plus a minimum of 20 feet into the underlying formation.
4. If the well is dry hole, an agreement between the operator and the district office on plug length and placement is necessary **prior to plugging**;
5. The appropriate district office will be notified before well is either plugged or production casing is cemented in;
6. If an ALTERNATE II COMPLETION, production pipe shall be cemented from below any usable water to surface within **120 days** of spud date.
Or pursuant to Appendix "B" - Eastern Kansas surface casing order #133,891-C, which applies to the KCC District 3 area, alternate II cementing must be completed within 30 days of the spud date or the well shall be plugged. **In all cases, NOTIFY district office** prior to any cementing.

I hereby certify that the statements made herein are true and to the best of my knowledge and belief.

Date: December 12, 2005 Signature of Operator or Agent: Scott Corsair Title: Petroleum Engineer

For KCC Use ONLY
API # 15 - 135-24431-0000
Conductor pipe required None feet
Minimum surface pipe required 200 feet per Alt. (2)
Approved by: RSP 12-13-05
This authorization expires 6-13-06
(This authorization void if drilling not started within 6 months of effective date.)
Spud date: _____ Agent: _____

Remember to:

- File Drill Pit Application (form CDP-1) with Intent to Drill;
- File Completion Form ACO-1 within 120 days of spud date;
- File acreage attribution plat according to field proration orders;
- Notify appropriate district office 48 hours prior to workover or re-entry;
- Submit plugging report (CP-4) after plugging is completed;
- Obtain written approval before disposing or injecting salt water.
- If this permit has expired (See: authorized expiration date) please check the box below and return to the address below.

Well Not Drilled - Permit Expired
Signature of Operator or Agent: _____
Date: _____

RECEIVED
DEC 12 2005
KCC WICHITA

19
19
ELW

IN ALL CASES PLOT THE INTENDED WELL ON THE PLAT BELOW

Plat of acreage attributable to a well in a prorated or spaced field

If the intended well is in a prorated or spaced field, please fully complete this side of the form. If the intended well is in a prorated or spaced field complete the plat below showing that the well will be properly located in relationship to other wells producing from the common source of supply. Please show all the wells and within 1 mile of the boundaries of the proposed acreage attribution unit for gas wells and within 1/2 mile of the boundaries of the proposed acreage attribution unit for oil wells.

API No. 15 - _____
 Operator: American Warrior, Inc.
 Lease: Wittman
 Well Number: 9
 Field: Schaben
 Number of Acres attributable to well: 10
 QTR / QTR / QTR of acreage: SW - SW - NE

Location of Well: County: Ness
2310 feet from N / S Line of Section
2310 feet from E / W Line of Section
 Sec. 19 Twp. 19 S. R. 21 East West

Is Section: Regular or Irregular

If Section is Irregular, locate well from nearest corner boundary.
 Section corner used: NE NW SE SW

PLAT

*(Show location of the well and shade attributable acreage for prorated or spaced wells.)
 (Show footage to the nearest lease or unit boundary line.)*

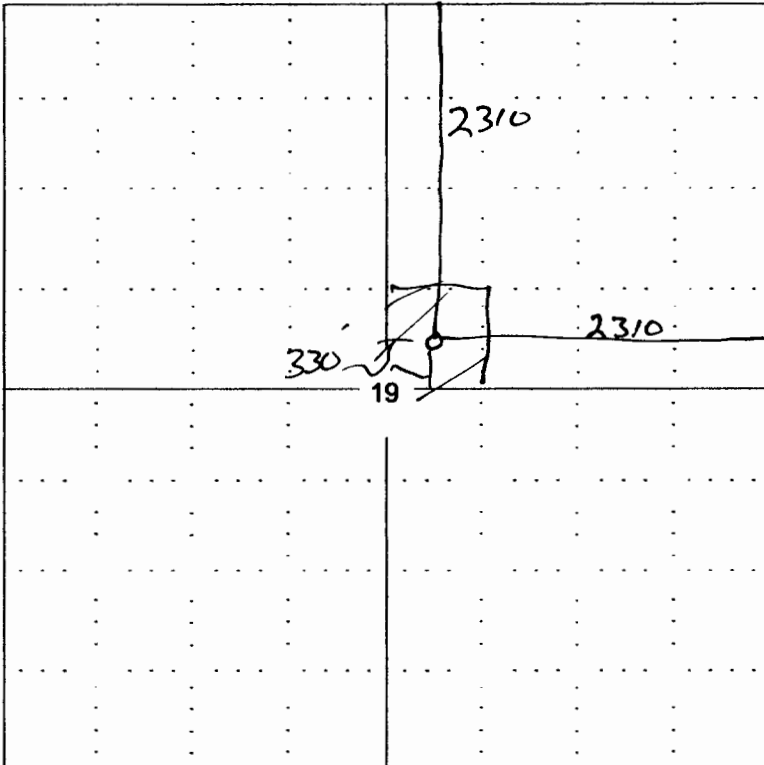

Ness CO.

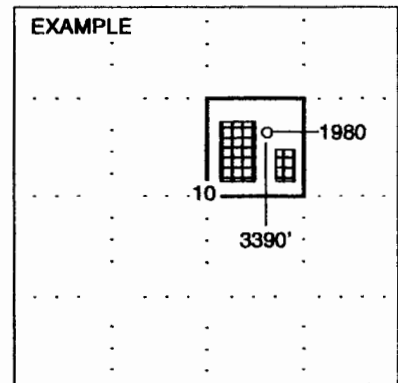

SEWARD CO.

NOTE: In all cases locate the spot of the proposed drilling location.

In plotting the proposed location of the well, you must show:

1. The manner in which you are using the depicted plat by identifying section lines, i.e. 1 section, 1 section with 8 surrounding sections, 4 sections, etc.
2. The distance of the proposed drilling location from the section's south / north and east / west.
3. The distance to the nearest lease or unit boundary line.
4. If proposed location is located within a prorated or spaced field a certificate of acreage attribution plat must be attached: (CO-7 for oil wells;