

For KCC Use:  
 Effective Date: 3-25-06  
 District #: 3  
 SGA?  Yes  No

KANSAS CORPORATION COMMISSION  
 OIL & GAS CONSERVATION DIVISION  
**NOTICE OF INTENT TO DRILL**

Form C-1  
 December 2002  
**Form must be Typed**  
**Form must be Signed**  
**All blanks must be Filled**

Must be approved by KCC five (5) days prior to commencing well

Expected Spud Date March 26, 2006  
 month day year

OPERATOR: License# 33074  
 Name: Dart Cherokee Basin Operating Co. LLC  
 Address: 211 W. Myrtle  
Independence KS 67301  
 City/State/Zip:  
 Contact Person: Tony Williams  
 Phone: 620-331-7870

CONTRACTOR: License# Unknown  
 Name: Will advise of licensed contractor on ACO-1

<b>Well Drilled For:</b>	<b>Well Class:</b>	<b>Type Equipment:</b>
<input type="checkbox"/> Oil	<input type="checkbox"/> Enh Rec	<input type="checkbox"/> Infield
<input checked="" type="checkbox"/> Gas	<input type="checkbox"/> Storage	<input checked="" type="checkbox"/> Pool Ext.
<input type="checkbox"/> OWWO	<input type="checkbox"/> Disposal	<input type="checkbox"/> Wildcat
<input type="checkbox"/> Seismic; # of Holes	<input type="checkbox"/> Other	<input type="checkbox"/> Mud Rotary
<input type="checkbox"/> Other		<input checked="" type="checkbox"/> Air Rotary
		<input type="checkbox"/> Cable

If OWWO: old well information as follows:  
 Operator: \_\_\_\_\_  
 Well Name: \_\_\_\_\_  
 Original Completion Date: \_\_\_\_\_ Original Total Depth: \_\_\_\_\_

Directional, Deviated or Horizontal wellbore?  Yes  No  
 If Yes, true vertical depth: \_\_\_\_\_  
 Bottom Hole Location: \_\_\_\_\_  
 KCC DKT #: \_\_\_\_\_

Spot 70' N of.  
 N2 SW SW Sec. 10 Twp. 33 S. R. 15E  
 East  
 West  
 1060 FSL \_\_\_\_\_ feet from  N /  S Line of Section  
 4620 FEL \_\_\_\_\_ feet from  E /  W Line of Section  
 Is SECTION  Regular  Irregular?

(Note: Locate well on the Section Plat on reverse side)  
 County: Montgomery  
 Lease Name: Ascarate Well #: D1-10  
 Field Name: Cherokee Basin Coal Gas Area  
 Is this a Prorated / Spaced Field?  Yes  No  
 Target Information(s): Mississippian  
 Nearest Lease or unit boundary: 660 feet  
 Ground Surface Elevation: 796 feet MSL  
 Water well within one-quarter mile:  Yes  No  
 Public water supply well within one mile:  Yes  No  
 Depth to bottom of fresh water: 100'  
 Depth to bottom of usable water: 200'  
 Surface Pipe by Alternate:  1  2  
 Length of Surface Pipe Planned to be set: 40"  
 Length of Conductor Pipe required: \_\_\_\_\_  
 Projected Total Depth: 1521 feet  
 Formation at Total Depth: Mississippian  
 Water Source for Drilling Operations:  
 Well  Farm Pond Other \_\_\_\_\_  
 DWR Permit #: \_\_\_\_\_  
 (Note: Apply for Permit with DWR )  
 Will Cores be taken?  Yes  No  
 If Yes, proposed zone: \_\_\_\_\_

**AFFIDAVIT**

The undersigned hereby affirms that the drilling, completion and eventual plugging of this well will comply with K.S.A. 55 et. seq.  
 It is agreed that the following minimum requirements will be met:

1. Notify the appropriate district office **prior** to spudding of well;
2. A copy of the approved notice of intent to drill **shall be** posted on each drilling rig;
3. The minimum amount of surface pipe as specified below **shall be set** by circulating cement to the top; in all cases surface pipe shall be set through all unconsolidated materials plus a minimum of 20 feet into the underlying formation.
4. If the well is dry hole, an agreement between the operator and the district office on plug length and placement is necessary **prior to plugging**;
5. The appropriate district office will be notified before well is either plugged or production casing is cemented in;
6. If an ALTERNATE II COMPLETION, production pipe shall be cemented from below any usable water to surface within **120 days** of spud date. Or pursuant to Appendix "B" - Eastern Kansas surface casing order #133,891-C, which applies to the KCC District 3 area, alternate II cementing must be completed within 30 days of the spud date or the well shall be plugged. **In all cases, NOTIFY district office** prior to any cementing.

I hereby certify that the statements made herein are true and to the best of my knowledge and belief.

Date: March 16, 2006 Signature of Operator or Agent: Tony Williams Title: Sr Regulatory & Safety Compliance Specialist

**For KCC Use ONLY**  
 API # 15 - 125-31013-00-00  
 Conductor pipe required NONE feet  
 Minimum surface pipe required 20' feet per Alt. **X 2**  
 Approved by: DPW 3-20-06  
 This authorization expires: 9-20-06  
 (This authorization void if drilling not started within 6 months of effective date.)  
 Spud date: \_\_\_\_\_ Agent: \_\_\_\_\_

**Remember to:**

- File Drill Pit Application (form CDP-1) with Intent to Drill;
- File Completion Form ACO-1 within 120 days of spud date;
- File acreage attribution plat according to field proration orders;
- Notify appropriate district office 48 hours prior to workover or re-entry;
- Submit plugging report (CP-4) after plugging is completed;
- Obtain written approval before disposing or injecting salt water.

- If this permit has expired (See: authorized expiration date) please check the box below and return to the address below.  
 **Well Not Drilled - Permit Expired**  
 Signature of Operator or Agent: \_\_\_\_\_  
 Date: \_\_\_\_\_

Mail to: KCC - Conservation Division, 130 S. Market - Room 2078, Wichita, Kansas 67202

RECEIVED  
 KANSAS CORPORATION COMMISSION  
 MAR 17 2006  
 CONSERVATION DIVISION  
 WICHITA, KS

10  
 33  
 15E

**IN ALL CASES PLOT THE INTENDED WELL ON THE PLAT BELOW**

*Plat of acreage attributable to a well in a prorated or spaced field*

**If the intended well is in a prorated or spaced field, please fully complete this side of the form.** If the intended well is in a prorated or spaced field complete the plat below showing that the well will be properly located in relationship to other wells producing from the common source of supply. Please show all the wells and within 1 mile of the boundaries of the proposed acreage attribution unit for gas wells and within 1/2 mile of the boundaries of the proposed acreage attribution unit for oil wells.

API No. 15 - \_\_\_\_\_  
 Operator: Dart Cherokee Basin Operating Co. LLC  
 Lease: Ascarate  
 Well Number: D1-10  
 Field: Cherokee Basin Coal Gas Area  
 Number of Acres attributable to well: 40  
 QTR / QTR / QTR of acreage: N2 - SW - SW

Location of Well: County: Montgomery  
1060 FSL feet from  N /  S Line of Section  
4620 FEL feet from  E /  W Line of Section  
 Sec. 10 Twp. 33 S. R. 15E  East  West

Is Section:  Regular or  Irregular

**If Section is Irregular, locate well from nearest corner boundary.**

Section corner used:  NE  NW  SE  SW

**PLAT**

*(Show location of the well and shade attributable acreage for prorated or spaced wells.)*

*(Show footage to the nearest lease or unit boundary line.)*

T33S

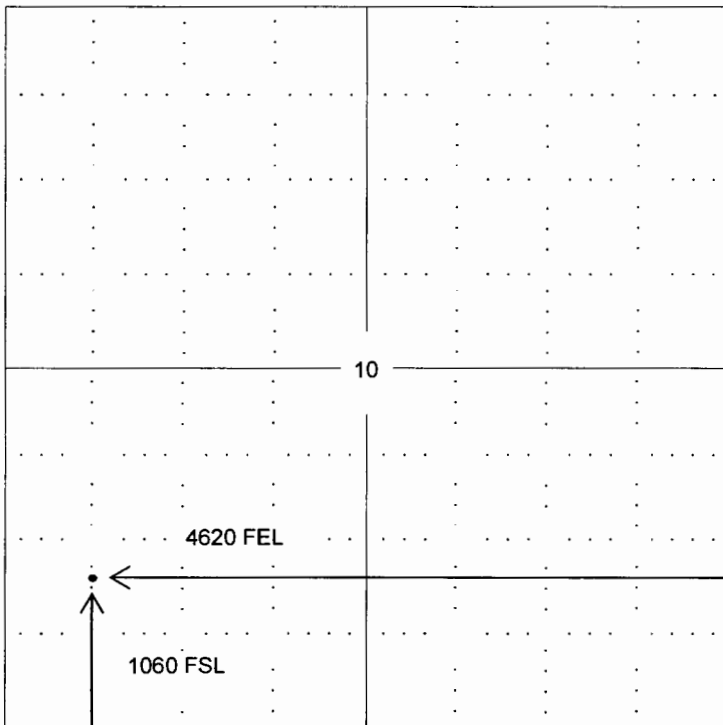

R15E

**RECEIVED**  
**KANSAS CORPORATION COMMISSION**  
**MAR 17 2006**  
**CONSERVATION DIVISION**  
**WICHITA, KS**

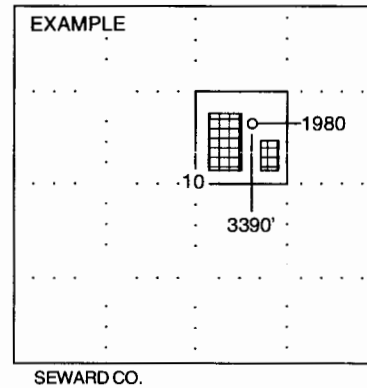

**NOTE: In all cases locate the spot of the proposed drilling location.** Montgomery Co.

**In plotting the proposed location of the well, you must show:**

1. The manner in which you are using the depicted plat by identifying section lines, i.e. 1 section, 1 section with 8 surrounding sections, 4 sections, etc.
2. The distance of the proposed drilling location from the section's south / north and east / west.
3. The distance to the nearest lease or unit boundary line.
4. If proposed location is located within a prorated or spaced field a certificate of acreage attribution plat must be attached: (C0-7 for oil wells; CG-8 for gas wells).