

MAY 04 2006

Form C-1
December 2002

For KCC Use: 67000
Effective Date: _____
District # 1
SGA? Yes No

KANSAS CORPORATION COMMISSION
OIL & GAS CONSERVATION DIVISION

CONSERVATION DIVISION
WICHITA, KS
Form must be Typed
Form must be Signed
All blanks must be Filled

NOTICE OF INTENT TO DRILL

Must be approved by KCC five (5) days prior to commencing well

Expected Spud Date July 1 2006
month day year

OPERATOR: License# 5364
Name: Beren Corp.
Address: P.O. Box 20380
Wichita, KS 67208
City/State/Zip: Wichita, KS 67208
Contact Person: Gary Misak
Phone: (316) 265-3311

CONTRACTOR: License# 5147
Name: Beredco Inc.

Spot East
N/2 NW - NW - NE Sec. 16 Twp. 16 S. R. 23 West
75 feet from N / S Line of Section
2350 feet from E / W Line of Section
Is SECTION Regular Irregular?

(Note: Locate well on the Section Plat on reverse side)

County: Ness
Lease Name: Willa Well #: 1-16
Field Name: Osgood

Is this a Prorated / Spaced Field? Yes No
Target Formation(s): Cherokee, Mississippi

* Nearest Lease or unit boundary: 75'
Ground Surface Elevation: 2430 feet MSL

Water well within one-quarter mile: Yes No
Public water supply well within one mile: Yes No

Depth to bottom of fresh water: 180
Depth to bottom of usable water: 1150

Surface Pipe by Alternate: 1 2
Length of Surface Pipe Planned to be set: 350'

Length of Conductor Pipe required: None
Projected Total Depth: 4500'

Formation at Total Depth: Mississippi
Water Source for Drilling Operations:
 Well Farm Pond Other _____

DWR Permit #: _____
(Note: Apply for Permit with DWR)

Will Cores be taken? Yes No
If Yes, proposed zone: _____

Well Drilled For: Oil Gas OWWO Seismic; # of Holes _____
 Enh Rec Storage Disposal Other _____
Well Class: Infield Pool Ext. Wildcat Other _____
Type Equipment: Mud Rotary Air Rotary Cable _____

If OWWO: old well information as follows:
Operator: _____
Well Name: _____
Original Completion Date: _____ Original Total Depth: _____

Directional, Deviated or Horizontal wellbore? Yes No
If Yes, true vertical depth: _____

Bottom Hole Location: _____
KCC DKT #: _____

* Declaration of pooling attached.

AFFIDAVIT

* WLE granted Docket 06-CONS-189-C WLE

The undersigned hereby affirms that the drilling, completion and eventual plugging of this well will comply with K.S.A. 55 et. seq.

It is agreed that the following minimum requirements will be met:

1. Notify the appropriate district office **prior** to spudding of well;
2. A copy of the approved notice of intent to drill **shall be** posted on each drilling rig;
3. The minimum amount of surface pipe as specified below **shall be set** by circulating cement to the top; in all cases surface pipe **shall be set** through all unconsolidated materials plus a minimum of 20 feet into the underlying formation.
4. If the well is dry hole, an agreement between the operator and the district office on plug length and placement is necessary **prior to plugging**;
5. The appropriate district office will be notified before well is either plugged or production casing is cemented in;
6. If an ALTERNATE II COMPLETION, production pipe shall be cemented from below any usable water to surface within **120 days** of spud date.
Or pursuant to Appendix "B" - Eastern Kansas surface casing order #133,891-C, which applies to the KCC District 3 area, alternate II cementing must be completed within 30 days of the spud date or the well shall be plugged. **In all cases, NOTIFY district office** prior to any cementing.

I hereby certify that the statements made herein are true and to the best of my knowledge and belief.

Date: May 3, 2006 Signature of Operator or Agent: Richard R. Smith Title: Engineering Technician

For KCC Use ONLY
API # 15 - 135-24506-0000
Conductor pipe required None feet
Minimum surface pipe required 200 feet per Alt. X(2)
Approved by: Rut 6-506
This authorization expires: 12-506
(This authorization void if drilling not started within 6 months of approval date.)
Spud date: _____ Agent: _____

Remember to:

- File Drill Pit Application (form CDP-1) with Intent to Drill;
- File Completion Form ACO-1 within 120 days of spud date;
- File acreage attribution plat according to field proration orders;
- Notify appropriate district office 48 hours prior to workover or re-entry;
- Submit plugging report (CP-4) after plugging is completed;
- Obtain written approval before disposing or injecting salt water.
- If this permit has expired (See: authorized expiration date) please check the box below and return to the address below.

Well Not Drilled - Permit Expired
Signature of Operator or Agent: _____
Date: _____

Mail to: KCC - Conservation Division, 130 S. Market - Room 2078, Wichita, Kansas 67202

16
16
23W

MAY 04 2006

CONSERVATION DIVISION
WICHITA, KS

Side Two

IN ALL CASES PLOT THE INTENDED WELL ON THE PLAT BELOW

Plat of acreage attributable to a well in a prorated or spaced field

If the intended well is in a prorated or spaced field, please fully complete this side of the form. If the intended well is in a prorated or spaced field complete the plat below showing that the well will be properly located in relationship to other wells producing from the common source of supply. Please show all the wells and within 1 mile of the boundaries of the proposed acreage attribution unit for gas wells and within 1/2 mile of the boundaries of the proposed acreage attribution unit for oil wells.

API No. 15 - 135-24500-0000
 Operator: Beren Corp.
 Lease: Willa
 Well Number: 1-16
 Field: Osgood

Number of Acres attributable to well: 10
 QTR / QTR / QTR of acreage: N/2 NW - NW - NE

Location of Well: County: Ness
75 feet from N / S Line of Section
2350 feet from E / W Line of Section
 Sec. 16 Twp. 16 S. R. 23 East West

Is Section: Regular or Irregular

If Section is Irregular, locate well from nearest corner boundary.

Section corner used: NE NW SE SW

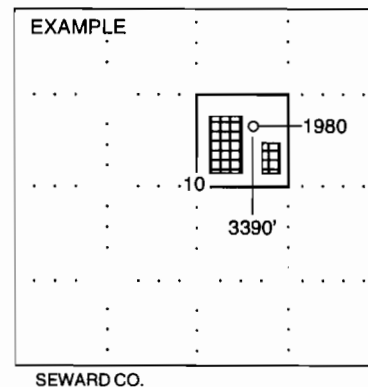
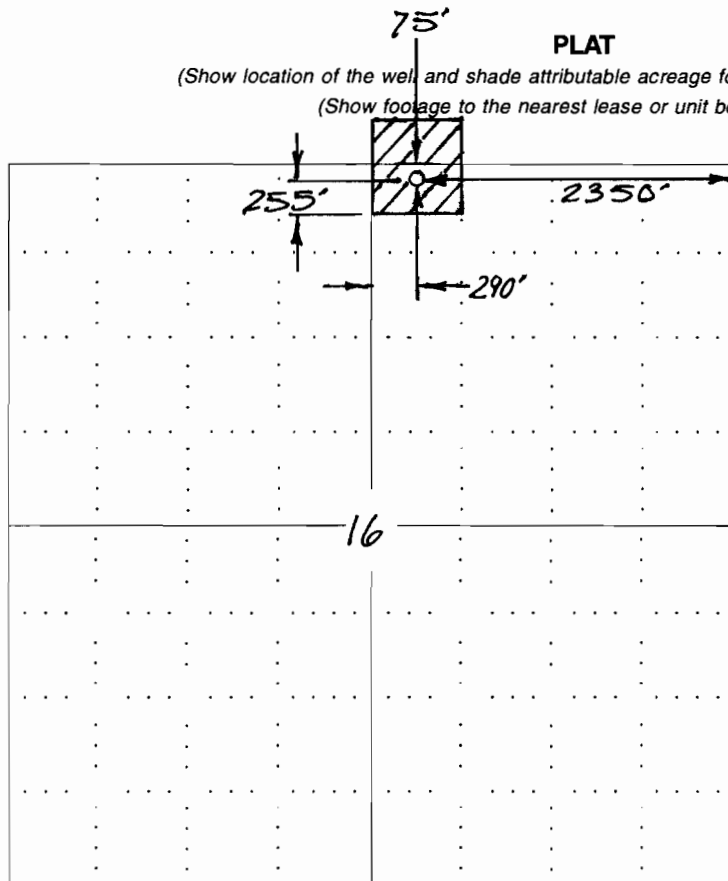

NOTE: In all cases locate the spot of the proposed drilling location.

In plotting the proposed location of the well, you must show:

1. The manner in which you are using the depicted plat by identifying section lines, i.e. 1 section, 1 section with 8 surrounding sections, 4 sections, etc.
2. The distance of the proposed drilling location from the section's south / north and east / west.
3. The distance to the nearest lease or unit boundary line.
4. If proposed location is located within a prorated or spaced field a certificate of acreage attribution plat must be attached: (C0-7 for oil wells; CG-8 for gas wells).

KANSAS CORPORATION COMMISSION
OIL & GAS CONSERVATION DIVISION
APPLICATION FOR SURFACE PIT

RECEIVED
KANSAS CORPORATION COMMISSION
Form GDP-1
April 2004
MAY 04 2006 Form must be Typed
CONSERVATION DIVISION
WICHITA, KS

Submit In Duplicate

Operator Name: Beren Corp.		License Number: 5364
Operator Address: P.O. Box 20380, Wichita, KS, 67208		
Contact Person: Gary Misak		Phone Number: (316) 265 - 3311
Lease Name & Well No.: Willa #1-16		Pit Location (QQQQ): N/2 - NW - NW - NE
Type of Pit: <input type="checkbox"/> Emergency Pit <input type="checkbox"/> Burn Pit <input type="checkbox"/> Settling Pit <input checked="" type="checkbox"/> Drilling Pit <input type="checkbox"/> Workover Pit <input type="checkbox"/> Haul-Off Pit <i>(If WP Supply API No. or Year Drilled)</i>	Pit is: <input checked="" type="checkbox"/> Proposed <input type="checkbox"/> Existing If Existing, date constructed: _____ Pit capacity: 7000 (bbls)	Sec. 16 Twp. 16 R. 23 <input type="checkbox"/> East <input checked="" type="checkbox"/> West 75 Feet from <input checked="" type="checkbox"/> North / <input type="checkbox"/> South Line of Section 2350 Feet from <input checked="" type="checkbox"/> East / <input type="checkbox"/> West Line of Section Ness _____ County
Is the pit located in a Sensitive Ground Water Area? <input type="checkbox"/> Yes <input checked="" type="checkbox"/> No		Chloride concentration: _____ mg/l <i>(For Emergency Pits and Settling Pits only)</i>
Is the bottom below ground level? <input checked="" type="checkbox"/> Yes <input type="checkbox"/> No	Artificial Liner? <input type="checkbox"/> Yes <input checked="" type="checkbox"/> No	How is the pit lined if a plastic liner is not used?
Pit dimensions (all but working pits): 100 Length (feet) 100 Width (feet) _____ N/A: Steel Pits Depth from ground level to deepest point: 4 (feet)		
If the pit is lined give a brief description of the liner material, thickness and installation procedure.		Describe procedures for periodic maintenance and determining liner integrity, including any special monitoring.
Distance to nearest water well within one-mile of pit 3187 feet Depth of water well 42 feet	Depth to shallowest fresh water 35 feet. Source of information: KH KCS _____ measured _____ well owner _____ electric log ① KDWR	
Emergency, Settling and Burn Pits ONLY: Producing Formation: _____ Number of producing wells on lease: _____ Barrels of fluid produced daily: _____ Does the slope from the tank battery allow all spilled fluids to flow into the pit? <input type="checkbox"/> Yes <input type="checkbox"/> No	Drilling, Workover and Haul-Off Pits ONLY: Type of material utilized in drilling/workover: Bentonite Mud Number of working pits to be utilized: 4 Abandonment procedure: Allow liquid to evaporate until bottom of pit is dry, then fill and level to contour of ground. Drill pits must be closed within 365 days of spud date.	
I hereby certify that the above statements are true and correct to the best of my knowledge and belief.		
_____ May 3, 2006 _____ Date		_____ <i>Michael R. Smith</i> _____ Signature of Applicant or Agent

15-135-24506-0000

KCC OFFICE USE ONLY			
Date Received: 5/4/06	Permit Number: _____	Permit Date: 5/4/06	Lease Inspection: <input type="checkbox"/> Yes <input checked="" type="checkbox"/> No

Mail to: KCC - Conservation Division, 130 S. Market - Room 2078, Wichita, Kansas 67202