

For KCC Use:

Effective Date: 7-29-06

District # 1

SGA? Yes No

NOTICE OF INTENT TO DRILL
Must be approved by KCC five (5) days prior to commencing well

Form must be Typed
Form must be Signed
All blanks must be Filled

Expected Spud Date _____
month day year

Spot _____ East
SW NE SE Sec 8 Twp 31 S. R. 37 West

OPERATOR: License # 5278
Name: EOG Resources, Inc.
Address: 3817 NW Expressway, Suite 500
City/State/Zip: Oklahoma City, Oklahoma 73112
Contact Person: BREANNA VARGAS
Phone: 405-246-3158

1765 feet from N / S Line of Section
540 feet from E / W Line of Section
Is SECTION Regular Irregular?

(Note: Locate well on Section Plat on Reverse Side)

CONTRACTOR: License #: 30684
Name: ABERCROMBIE RID, INC.

County: STEVENS
Lease Name: RIVERBEND Well #: 8 #1
Field Name: _____

Is this a Prorated/Spaced Field? Yes No
Target Formation(s): MORROW

Nearest Lease or unit boundary: 540'
Ground Surface Elevation: 3109' feet MSL

Water well within one-quarter mile: yes no
Public water supply within one mile: yes no

Depth to bottom of fresh water: 620' 520
Depth to bottom of usable water: 680' 600

Surface Pipe by Alternate: 1 2

Length of Surface Pipe Planned to be set: 1700'
Length of Conductor pipe required: 40'

Projected Total Depth: 5600'
Formation at Total Depth: MORROW

Water Source for Drilling Operations:
Well Farm Pond Other _____

DWR Permit #: _____
(Note: Apply for Permit with DWR)

Will Cores Be Taken?: Yes No
If yes, proposed zone: _____

Well Drilled For: Well Class: Type Equipment:
 Oil Enh Rec Infield Mud Rotary
 Gas Storage Pool Ext. Air Rotary
 OWWO Disposal Wildcat Cable
 Seismic; # of Holes Other
 Other _____

If OWWO: old well information as follows:
Operator: _____
Well Name: _____
Original Completion Date: _____ Original Total Depth _____

Directional, Deviated or Horizontal wellbore? Yes No
If yes, true vertical depth: 5600'
Bottom Hole Location 1765' FSL & 897' EEL

KCC DKT # 07-CONS-001-CHOR
PRORATED & SPACED HUGOTON & PANOMA

AFFIDAVIT

The undersigned hereby affirms that the drilling, completion and eventual plugging of this well will comply with K.S.A. 38-1501, et seq.
It is agreed that the following minimum requirements will be met:

RECEIVED
KANSAS CORPORATION COMMISSION
JUL 05 2006
CONSERVATION DIVISION
WICHITA, KS

1. Notify the appropriate district office *prior* to spudding of well;
2. A copy of the approved notice of intent to drill *shall be* posted on each drilling rig;
3. The minimum amount of surface pipe as specified below *shall be set* by circulating cement to the top; in all cases surface pipe *shall be set* through all unconsolidated materials plus a minimum of 20 feet into the underlying formation;
4. If the well is dry hole, an agreement between the operator and the district office on plug length and placement is *necessary prior to plugging*;
5. The appropriate district office will be notified before well is either plugged or production casing is cemented in;
6. If an ALTERNATE II COMPLETION, production pipe shall be cemented from below any usable water to surface within **120 days** of spud date. Or pursuant to Appendix "B" - Eastern Kansas surface casing order #133,891-C, which applies to the KCC District 3 area, alternate II cementing must be completed within 30 days of the spud date or the well shall be plugged. *In all cases, NOTIFY district office* prior to any cementing.

I hereby certify that the statements made herein are true and to the best of my knowledge and belief.

Date: 6/26/06 Signature of Operator or Agent: Breanna Vargas Title: OPERATIONS ASSISTANT

For KCC Use ONLY
API # 15- 189-22545-01-00
Conductor pipe required None feet
Minimum surface pipe required 620 feet per Alt. 1
Approved by: RuH 7-24-06
This authorization expires: 1-24-07
(This authorization void if drilling not started within 6 months of effective date.)
Spud date: _____ Agent _____

Remember to:
- File Drill Pit Application (form CDP-1) with Intent to Drill;
- File Completion Form ACO-1 within 120 days of spud date;
- File acreage attribution plat according to field proration orders;
- Notify appropriate district office 48 hours prior to workover or re-entry;
- Submit plugging report (CP-4) after plugging is completed;
- Obtain written approval before disposing or injecting salt water.
- If permit has expired (See: authorized expiration date) please check the box below and return to the address below
 Well Not Drilled - Permit Expired
Signature of Operator or Agent: _____
Date: _____

8-31-37W

IN ALL CASES PLOT THE INTENDED WELL ON THE PLAT BELOW

Plat of acreage attributable to a well in a prorated or spaced field

If the intended well is in a prorated or spaced field, please fully complete this side of the form. If the intended well is in a prorated or spaced field complete the plat below showing that the well will be properly located in relationship to other wells producing from the common source of supply. Please show all the wells within 1 mile of the boundaries of the proposed acreage attribution unit for gas wells and within 1/2 mile of the boundaries of the proposed acreage attribution unit for oil wells.

API No. 15- 189-22545-01-00
 Operator EOG Resources, Inc.
 Lease RIVERBEND
 Well Number 8 #1
 Field _____

Location of Well: County: STEVENS
 _____ 1765 feet from N / S Line of Section
 _____ 540 feet from E / W Line of Section
 Sec 8 Twp 31 S. R 37 East West

Number of Acres attributable to well: _____
 QTR/QTR/QTR of acreage: SE - NW - SE

Is Section X Regular or _____ Irregular
If Section is irregular, locate well from nearest corner boundary.
 Section corner used: _____ NE _____ NW _____ SE _____ SW

PLAT

*(Show location of the well and shade attributable acreage for prorated or spaced wells.)
 (Show footage to nearest lease or unit boundary line)*

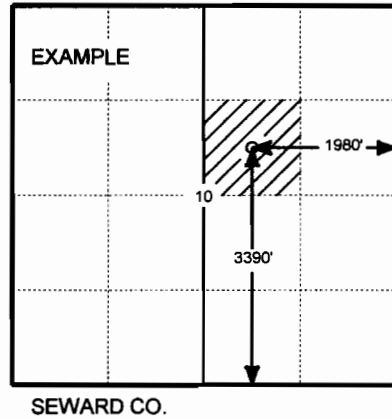
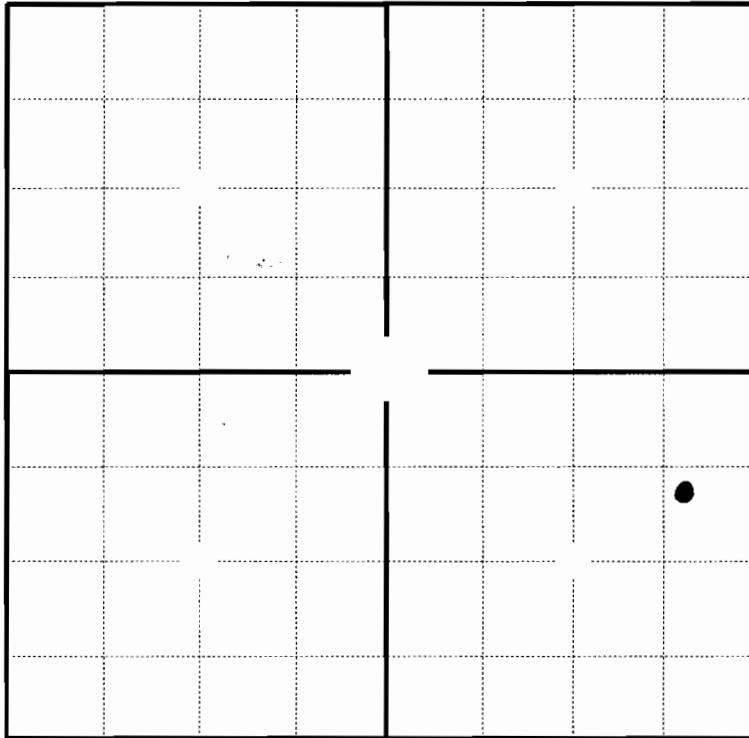

In plotting the proposed location of the well, you must show;

1. The manner in which you are using the depicted plat by identifying section lines, i.e. 1 section, 1 section with 8 surrounding sections, 4 sections, etc.;
2. The distance of the proposed drilling location from the section's south/north and east/west; and 3.
3. The distance to the nearest lease or unit boundary line.
4. If proposed location is located within a prorated or spaced field a certificate of acreage attribution plat must be attached: (CO-7 for oil wells; CG-8 for gas wells).

**KANSAS CORPORATION COMMISSION
OIL & GAS CONSERVATION DIVISION
APPLICATION FOR SURFACE PIT**

Form CDP-1
April 2004
Form must be Typed

Submit in Duplicate

Operator Name: EOG Resources, Inc.		License Number: 5278
Operator Address: 3817 NW Expressway Suite #500 Oklahoma City, OK 73112		
Contact Person: Breanna Vargas		Phone Number: (405) 246 - 3158
Lease Name & Well No.: Riverbend 8 #1		Pit Location (QQQQ): NW - SE - NE - SE
Type of Pit: <input type="checkbox"/> Emergency Pit <input type="checkbox"/> Burn Pit <input type="checkbox"/> Settling Pit <input checked="" type="checkbox"/> Drilling Pit <input type="checkbox"/> Workover Pit <input type="checkbox"/> Haul-Off Pit <i>(If WP Supply API No. or Year Drilled)</i>		Pit is: <input checked="" type="checkbox"/> Proposed <input type="checkbox"/> Existing If Existing, date constructed: _____ Pit capacity: _____ 12,500 (bbls)
Is the pit located in a Sensitive Ground Water Area? <input type="checkbox"/> Yes <input checked="" type="checkbox"/> No		Chloride concentration: _____ mg/l <i>(For Emergency Pits and Settling Pits only)</i>
Is the bottom below ground level? <input checked="" type="checkbox"/> Yes <input type="checkbox"/> No	Artificial Liner? <input type="checkbox"/> Yes <input checked="" type="checkbox"/> No	How is the pit lined if a plastic liner is not used?
Pit dimensions (all but working pits): <u>125</u> Length (feet) <u>125</u> Width (feet) _____ N/A: Steel Pits Depth from ground level to deepest point: <u>5</u> (feet)		
If the pit is lined give a brief description of the liner material, thickness and installation procedure.		Describe procedures for periodic maintenance and determining liner integrity, including any special monitoring.
Distance to nearest water well within one-mile of pit <u>464</u> feet Depth of water well <u>450</u> feet		Depth to shallowest fresh water <u>250</u> ²⁶² feet. <i>LN 262</i> Source of information: <input checked="" type="checkbox"/> measured _____ well owner _____ electric log _____ KDWR
Emergency, Settling and Burn Pits ONLY: Producing Formation: _____ Number of producing wells on lease: _____ Barrels of fluid produced daily: _____ Does the slope from the tank battery allow all spilled fluids to flow into the pit? <input type="checkbox"/> Yes <input type="checkbox"/> No		Drilling, Workover and Haul-Off Pits ONLY: Type of material utilized in drilling/workover: <u>Gel</u> Number of working pits to be utilized: <u>None</u> Abandonment procedure: <u>Evaporation/dewater and backfilling of reserve pit.</u> Drill pits must be closed within 365 days of spud date.
I hereby certify that the above statements are true and correct to the best of my knowledge and belief.		
_____ 6/26/06 Date		_____ <i>Breanna Vargas</i> Signature of Applicant or Agent
KCC OFFICE USE ONLY		
Date Received: <u>7/5/06</u> Permit Number: _____ Permit Date: <u>7/6/06</u> Lease Inspection: <input type="checkbox"/> Yes <input checked="" type="checkbox"/> No		

RECEIVED
KANSAS CORPORATION COMMISSION
JUL 05 2006
CONSERVATION DIVISION
WICHITA, KS

15-189-22545-01-00