

KANSAS CORPORATION COMMISSION
OIL & GAS CONSERVATION DIVISION

Form CP-1
September 2003
Form must be Typed
Form must be Signed
All blanks must be Filled

WELL PLUGGING APPLICATION

Please TYPE Form and File ONE Copy

API # ~~15~~ 15-055-00379-00-00 (Identifier Number of this well). This must be listed for wells drilled since 1967; if no API # was issued.

Indicate original spud or completion date S12-04-46 C

Well Operator: BP AMERICA PRODUCTION COMPANY KCC License #: 5952

Address: P. O. BOX 3092, WL1 RM 3.201 (Owner/Company Name) City: HOUSTON (Operator's)

State: TEXAS Zip Code: 77253-3092 Contact Phone: 281 366-4395

Lease: ANDERSON A Well #: 1 Sec. 3 Twp. 23 S R. 34 East West

SW SW NE Spot Location/QQQQ County FINNEY

2640 Feet from (in exact footage) North / South (from nearest outside section corner) Line of Section (not Lease Line)

2640 Feet from (in exact footage) East / West (from nearest outside section corner) Line of Section (not Lease Line)

Check One: Oil Well Gas Well D&A Cathodic Water Supply Well
 SWD Docket # _____ ENHR Docket # _____ Other _____

Conductor Casing Size: _____ Set at: _____ Cemented with: _____ Sacks

Surface Casing Size: 8 - 5/8" Set at: 1005' Cemented with: 500 Sacks

Production Casing Size: 5 - 1/2" Set at: 2662' Cemented with: 400 Sacks

List (ALL) Perforations and Bridgeplug Sets: PERFS: 2492-2638' CIBP: 2460'

Elevation: 2944' (G.L. K.B.) T.D. 2662' PBDT _____ Anhydrite Depth _____
(Stone Corral Formation)

Condition of Well: Good Poor Casing Leak Junk in Hole

Proposed Method of Plugging (attach a separate page if additional space is needed): SEE ATTACHED PROCEDURES.

Is Well Log attached to this application as required? Yes No Is ACO-1 filed? Yes No

If not explain why? _____

Plugging of this Well will be done in accordance with K.S.A. 55-101 et. seq. and the Rules and Regulations of the State Corporation Commission

List Name of Company Representative authorized to be in charge of plugging operations:
DEANN SMYERS Phone: 281 366-4395

Address: P. O. BOX 3092, WL 1, RM 3.201 City/State HOUSTON, TEXAS 77253-3092

Plugging Contractor HALLIBURTON SERVICES KCC License # 5287 99997
(Company Name) (Contractor's)

Address _____ Phone: _____

Proposed Date and Hour of Plugging (if known?): _____

Payment of the Plugging Fee (K.A.R. 82-3-118) will be guaranteed by Operator or Agent

Date: JULY 26, 2006 Authorized Operator / Agent: DeAnn Smyers
(Signature)

Mail to: KCC - Conservation Division, 130 S. Market - Room 2078, Wichita, Kansas 67202

Aug 6 2006
8-3-06
KCC WICHITA

Plugging Application
Anderson A 1 - Abandonment
Sec 3, T23S, R34W
Finney County, Kansas

The application attached is to abandon the Anderson A 1. BP Amoco is abandoning this well as it has become uneconomic to operate.

JG 03 2006
KCC WICHITA

**Plugging Procedure for the Anderson A 1
Section 3 T23S R34W
Finney County, Kansas**

NOTE – NOTIFY KCC DISTRICT OFFICE AT LEAST FIVE DAYS IN ADVANCE OF WORK.

This procedure was approved via a telephone conversation between Joe Eudey (BP representative) and Steve Durant (KCC) on February 15, 2006.

PROPOSED PROCEDURE:

1. Pull 3.5" liner and Baker packer.
2. Set CIBP (with 2 sacks of cement on top of plug) at 2460'.
3. Fill casing with water and run CBL to determine TOC
4. **STOP**. Consult with the Dodge City KCC office. Depth of circulating holes will need to be determined once TOC is found.

5. Circulate cement down 5.5" casing, through circulating holes, and out annulus between 8.625" & 5.5" casings. Leave annulus and 5.5" casing full of cement from ground level to circulating holes.

6. Cut off and cap casings 5' below ground level.
7. Restore the location.

CEMENT INFORMATION

60/40 class C premium plus cement w/6% gel.

Cement mixed at 13.1 ppg

Cement yield 1.53 cuft/sk

AUG 11 3 2006
KCC WICHITA

Anderson A 1
Section 3, T23S, R34W
Chase Formation
Hugoton Field
Finney County, Kansas

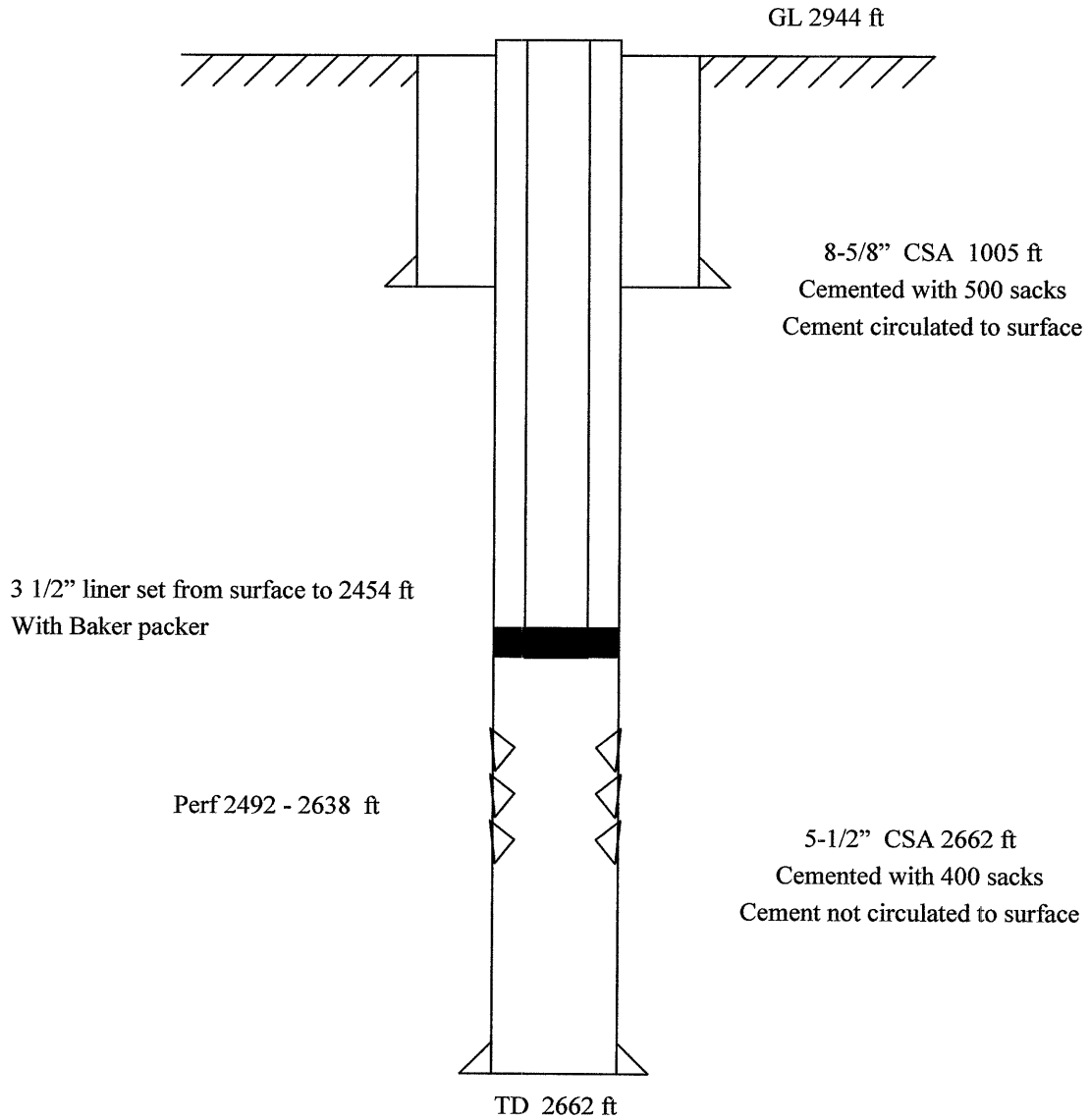

Not to scale

JUN 15 2006
KCC WICHITA

Anderson A 1
Section 3, T23S, R34W
Chase Formation
Hugoton Field
Finney County, Kansas

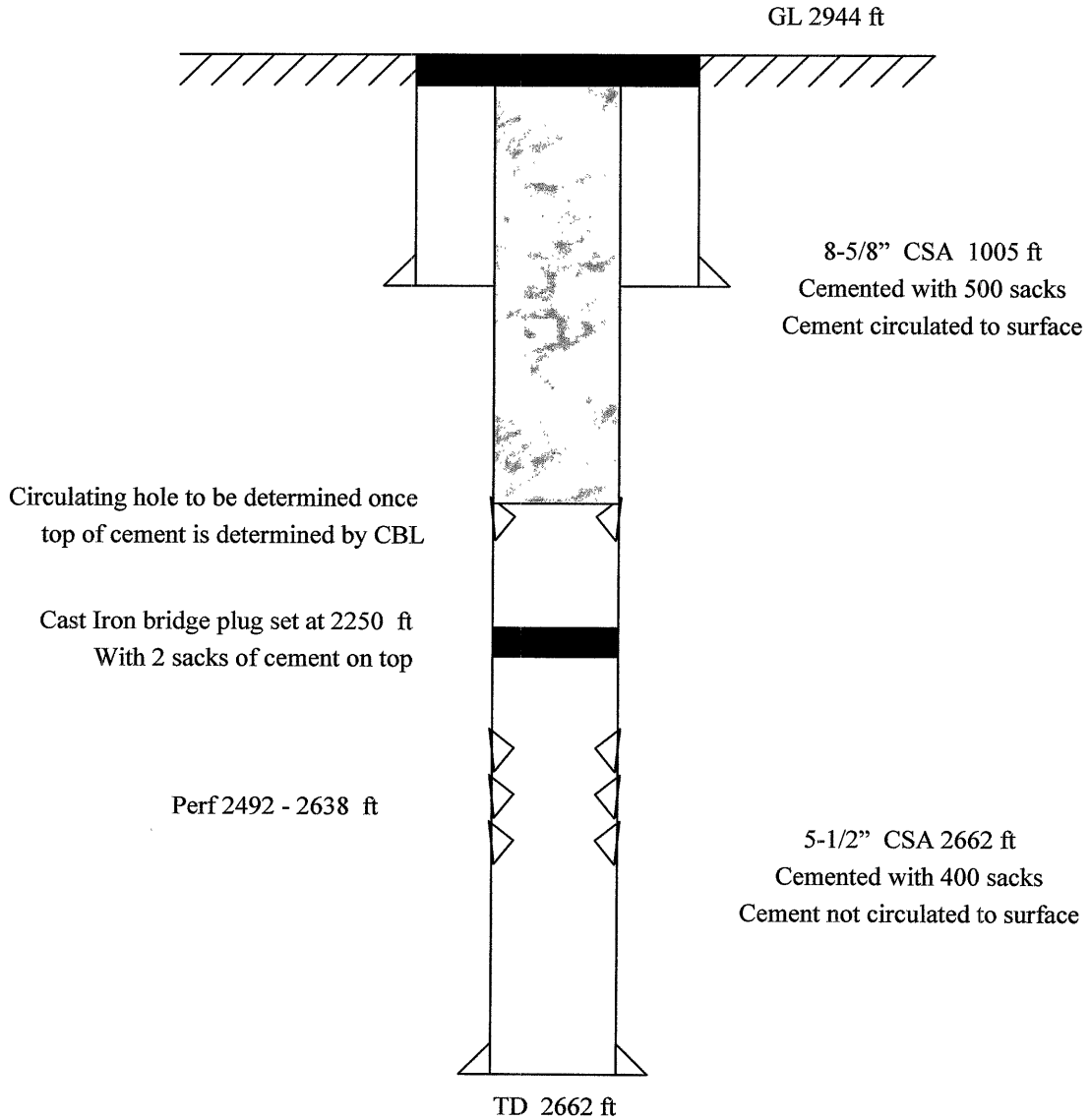

Not to scale

AUG 03 2006
KCC WICHITA



KANSAS

CORPORATION COMMISSION

Kathleen Sebelius, Governor Brian J. Moline, Chair Robert E. Krehbiel, Commissioner Michael C. Moffet, Commissioner

NOTICE OF RECEIPT OF WELL PLUGGING APPLICATION (CP-1)

BP America Production Company
2225 West Oklahoma Avenue
Ulysses, KS 67880

August 11, 2006

Re: ANDERSON #1
API 15-055-00379-00-00
C 3-23S-34W, 2640 FNL 2640 FWL
FINNEY COUNTY, KANSAS

Dear Operator:

This letter is to notify you that the Conservation Division is in receipt of your plugging proposal, form CP-1, for the above-captioned well.

Your CP-1 has been reviewed by the Conservation Division central office for completeness and to verify license numbers. The plugging proposal will now be forwarded to the district office listed below for review of your proposed method of plugging.

Please contact the district office for approval of your proposed plugging method at least five (5) days before plugging the well, pursuant to K.A.R. 82-3-113 (b). If a workover pit will be used during the plugging of the well it must be permitted. A CDP-1 form must be filed and approved prior to the use of the pit.

The Conservation Division's review of form CP-1, either in the central or district office, does not include an inquiry into well ownership or the filing operator's legal right to plug the well.

This notice in no way constitutes authorization to plug the above-captioned well by persons not having legal rights of ownership or interest in the well. This notice is void after ninety (90) days from the above date.

District: #1
210 E Frontview, Suite A
Dodge City, KS 67801
(620) 225-8888

Sincerely

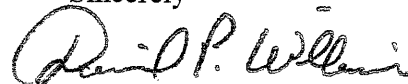

David P. Williams
Production Supervisor