

KANSAS CORPORATION COMMISSION
OIL & GAS CONSERVATION DIVISION

Form CP-1
September 2003
Form must be Typed
Form must be Signed
All blanks must be Filled

WELL PLUGGING APPLICATION

Please TYPE Form and File ONE Copy

API # 15- 055-00434-00-00 (Identifier Number of this well). This must be listed for wells drilled since 1967; if no API # was issued.

Indicate original spud or completion date S09-03-46 C03-24-53

Well Operator: BP AMERICA PRODUCTION COMPANY KCC License #: 5952

Address: P. O. BOX 3092, WL1 RM 11.141 City: HOUSTON
(Owner/Company Name) (Operator's)

State: TEXAS Zip Code: 77253-3092 Contact Phone: 281 366-4395

Lease: Shrimplin Gas Unit Well #: 1 Sec. 7 Twp. 24 S R. 33 W East West

NW NW NW SE Spot Location/QQQQ County FINNEY

2490 Feet from (in exact footage) North / South (from nearest outside section corner) Line of Section (not Lease Line)

2490 Feet from (in exact footage) East / West (from nearest outside section corner) Line of Section (not Lease Line)

Check One: Oil Well Gas Well D&A Cathodic Water Supply Well
 SWD Docket # _____ ENHR Docket # _____ Other _____

Conductor Casing Size: _____ Set at: _____ Cemented with: _____ Sacks

Surface Casing Size: 8 - 5/8" Set at: 847' Cemented with: 500 Sacks

Production Casing Size: 5 - 1/2" Set at: 2639' Cemented with: 900 Sacks

List (ALL) Perforations and Bridgeplug Sets: 2512-2620'

Elevation: 2819' (G.L. K.B.) T.D. 2650' PBDT _____ Anhydrite Depth _____
(Stone Corral Formation)

Condition of Well: Good Poor Casing Leak Junk in Hole

Proposed Method of Plugging (attach a separate page if additional space is needed): SEE ATTACHED PROCEDURES.

Is Well Log attached to this application as required? Yes No Is ACO-1 filed? Yes No

If not explain why? _____

Plugging of this Well will be done in accordance with K.S.A. 55-101 et. seq. and the Rules and Regulations of the State Corporation Commission

List Name of Company Representative authorized to be in charge of plugging operations:
DEANN SMYERS Phone: 281 366-4395

Address: P. O. BOX 3092, WL 1, RM 11.141 City/State HOUSTON, TEXAS 77253-3092

Plugging Contractor HALLIBURTON SERVICES KCC License # 5287
(Company Name) (Contractor's)

Address _____ Phone: _____

Proposed Date and Hour of Plugging (if known?): _____

Payment of the Plugging Fee (K.A.R. 82-3-118) will be guaranteed by Operator or Agent

Date: AUGUST 28, 2006 Authorized Operator / Agent: [Signature]
(Signature)

RECEIVED
SEP 05 2006
KCC WICHITA

Plugging Application
Shrimplin 1 - Abandonment
Sec 7, T24S, R33W
Finney County, Kansas

The application attached is to abandon the Shrimplin 1. BP Amoco is abandoning this well as it has become uneconomic to operate.

RECEIVED
SEP 05 2006
KCC WICHITA

**Plugging Procedure for the Shrimplin 1
Section 7 T24S R33W
Finney County, Kansas**

NOTE – NOTIFY KCC DISTRICT OFFICE AT LEAST FIVE DAYS IN ADVANCE OF WORK.

This procedure was approved via a telephone conversation between Joe Eudey (BP representative) and Steve Durant (KCC) on August 11, 2006.

PROPOSED PROCEDURE:

1. Pump 283 sacks of cement with 800 pounds of cottonseed hulls in the lead slurry to fill the 5.5" casing from ground level to 2650'. Pressure casing to 300 psi.
2. Have 50 sacks of extra cement on location to fill 8.625" X 5.5" annulus. Pressure annulus to 300 psi.
3. Cut off and cap casing 5' below ground level.
4. Restore the location.

CEMENT INFORMATION

60/40 class C premium plus cement w/6% gel.
Cement mixed at 13.1 ppg
Cement yield 1.53 cuft/sk

**RECEIVED
SEP 05 2006
KCC WICHITA**

Shrimplin 1
Section 7, T24S, R33W
Chase Formation
Hugoton Field
Finney County, Kansas

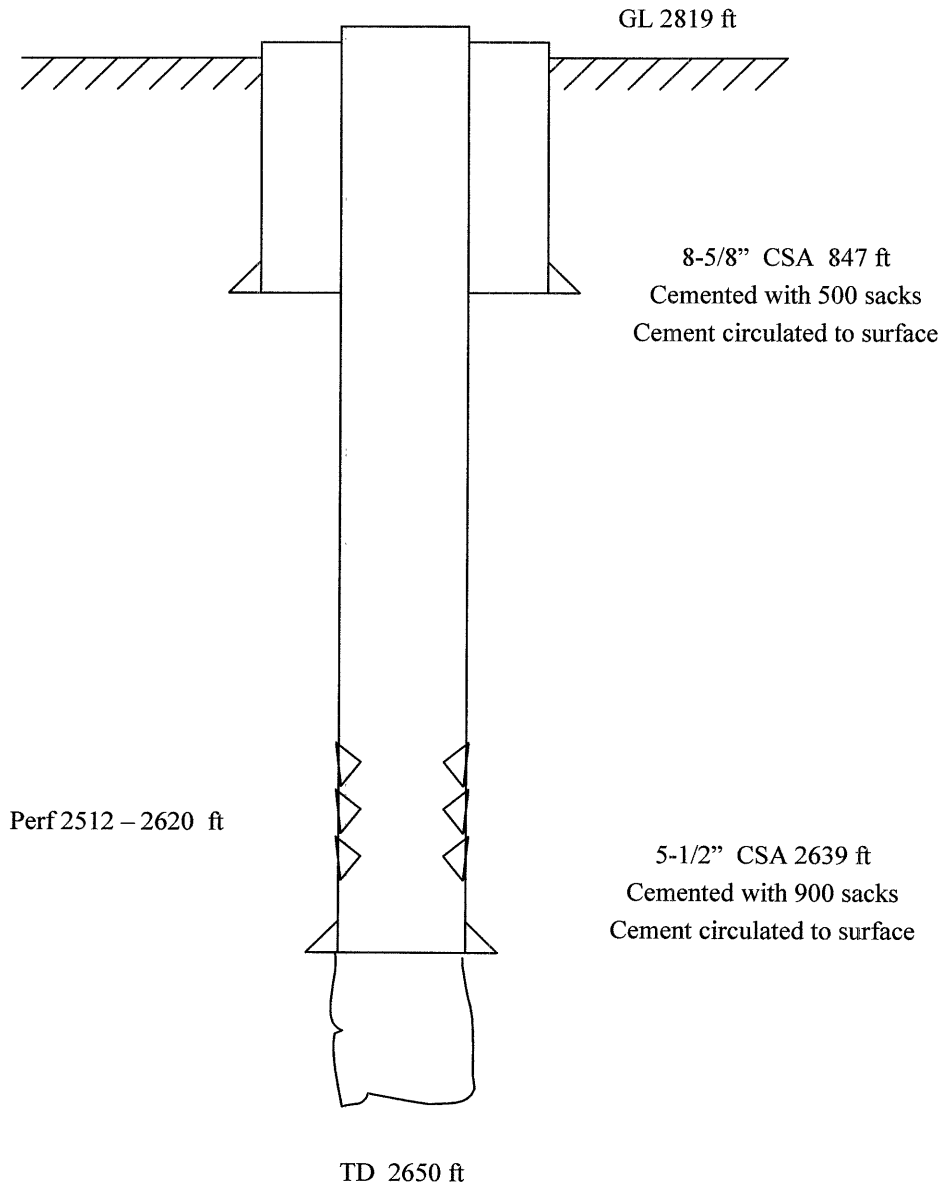

Not to scale

RECEIVED
SEP 05 2006
KCC WICHITA

Shrimplin 1
Section 7, T24S, R33W
Chase Formation
Hugoton Field
Finney County, Kansas

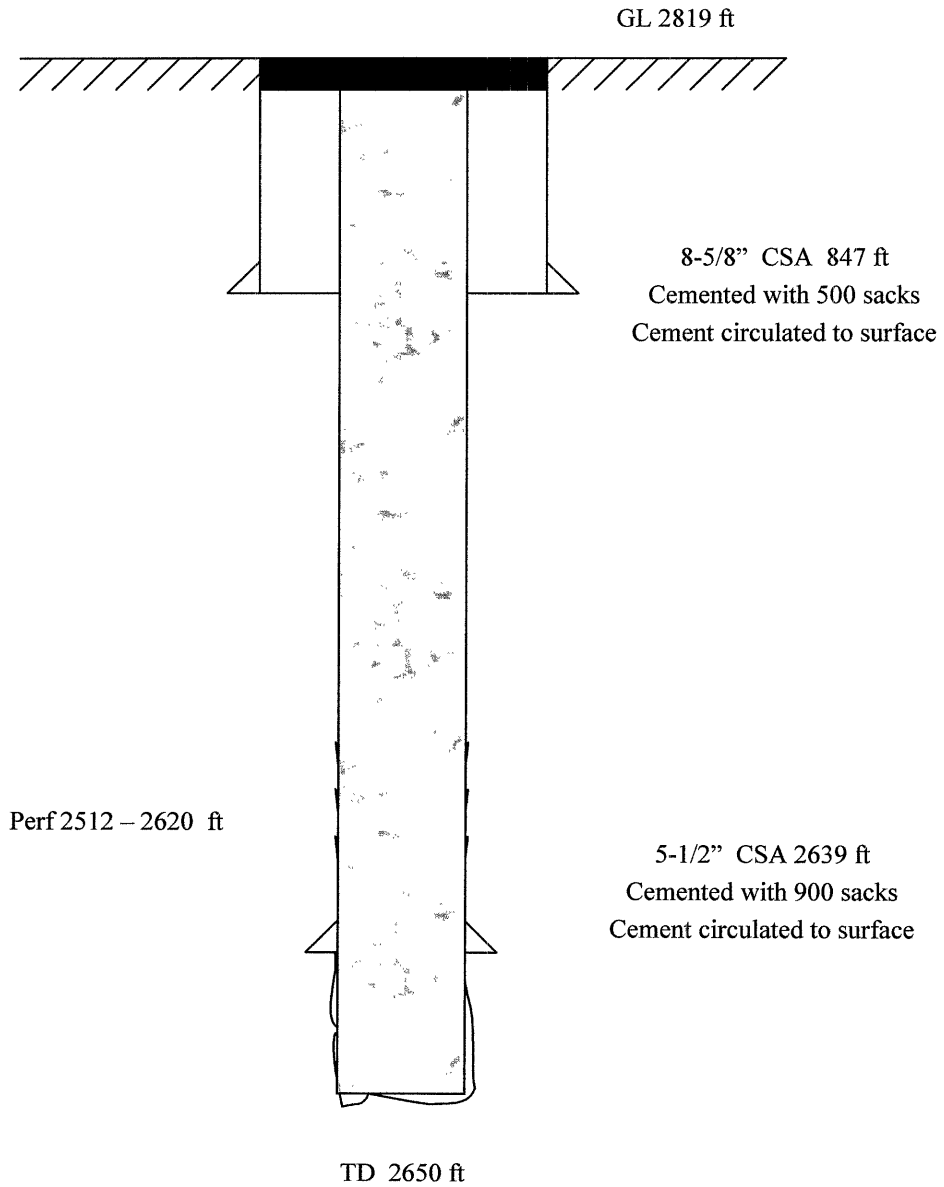

Not to scale

RECEIVED
SEP 05 2006
KCC WICHITA

STANOLIND OIL & GAS

#1 SCHRIMPLER

7-24-33W
APP CEN SEC

Contr. _____ FINNEY County

E 2882 Comm. _____ Comp. 4-17-53 IP 4,274,000 CFG

Tops	Depth	Datum
HER	2512	370
WINF	2578	304
TOW	2634	248
TD	2650	232

Casing
8" 847
5" 2639

PERF 2521-2620; ACID
17,000, R P 368#

HUGOTON FIELD

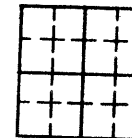

INDEPENDENT OIL & GAS SERVICE
WICHITA, KANSAS

NOTICE OF RECEIPT OF WELL PLUGGING APPLICATION (CP-1)

BP America Production Company
2225 West Oklahoma Avenue
Ulysses, KS 67880

September 20, 2006

Re: SHRIMPLIN GAS UNIT #1
API 15-055-00434-00-00
NWNWNWSE 7-24S-33W, 2490 FSL 2490 FEL
FINNEY COUNTY, KANSAS

Dear Operator:

This letter is to notify you that the Conservation Division is in receipt of your plugging proposal, form CP-1, for the above-captioned well.

Your CP-1 has been reviewed by the Conservation Division central office for completeness and to verify license numbers. The plugging proposal will now be forwarded to the district office listed below for review of your proposed method of plugging.

Please contact the district office for approval of your proposed plugging method at least five (5) days before plugging the well, pursuant to K.A.R. 82-3-113 (b). If a workover pit will be used during the plugging of the well it must be permitted. A CDP-1 form must be filed and approved prior to the use of the pit.

The Conservation Division's review of form CP-1, either in the central or district office, does not include an inquiry into well ownership or the filing operator's legal right to plug the well.

This notice in no way constitutes authorization to plug the above-captioned well by persons not having legal rights of ownership or interest in the well. This notice is void after ninety (90) days from the above date.

District: #1
210 E Frontview, Suite A
Dodge City, KS 67801
(620) 225-8888

Sincerely



David P. Williams
Production Supervisor