

For KCC Use: 8-26-07
 Effective Date: 8-26-07
 District #: 2
 SGA? Yes No

KANSAS CORPORATION COMMISSION
 OIL & GAS CONSERVATION DIVISION

Form C-1
 December 2002
 Form must be Typed
 Form must be Signed
 All blanks must be Filled

NOTICE OF INTENT TO DRILL

Must be approved by KCC five (5) days prior to commencing well

Expected Spud Date October 1, 2007
 month day year

OPERATOR: License# 33823
 Name: Sentinel Petroleum, Inc.
 Address: 101 N. Robinson, Suite 910
 City/State/Zip: Oklahoma City, OK 73102
 Contact Person: Suzanne M. Rogers
 Phone: 405-239-2150, Ext 15

CONTRACTOR: License# 32854
 Name: Gulick Drilling

Well Drilled For:	Well Class:	Type Equipment:
<input checked="" type="checkbox"/> Oil	<input type="checkbox"/> Enh Rec	<input checked="" type="checkbox"/> Mud Rotary
<input type="checkbox"/> Gas	<input type="checkbox"/> Storage	<input type="checkbox"/> Air Rotary
<input type="checkbox"/> OWWO	<input type="checkbox"/> Disposal	<input type="checkbox"/> Cable
<input type="checkbox"/> Seismic; # of Holes	<input type="checkbox"/> Wildcat	
<input type="checkbox"/> Other	<input type="checkbox"/> Pool Ext.	
	<input type="checkbox"/> Infield	
	<input type="checkbox"/> Other	

If OWWO: old well information as follows:
 Operator: _____
 Well Name: _____
 Original Completion Date: _____ Original Total Depth: _____
 Directional, Deviated or Horizontal wellbore? Yes No
 If Yes, true vertical depth: _____
 Bottom Hole Location: _____
 KCC DKT #: _____

Spot East
 NW - SE - NE Sec. 9 Twp. 35S S. R. 2 West
1650 feet from N / S Line of Section
990 feet from E / W Line of Section
 Is SECTION Regular Irregular?

(Note: Locate well on the Section Plat on reverse side)
 County: Sumner
 Lease Name: Horton-McClaskey Well #: 1
 Field Name: Murphy

Is this a Prorated / Spaced Field? Yes No
 Target Formation(s): Arbuckle

Nearest Lease or unit boundary: 0' see leases attached

Ground Surface Elevation: 1162 feet MSL

Water well within one-quarter mile: Yes No

Public water supply well within one mile: Yes No

Depth to bottom of fresh water: 50'

Depth to bottom of usable water: 230'

Surface Pipe by Alternate: 1 2

Length of Surface Pipe Planned to be set: 300'

Length of Conductor Pipe required: N/A

Projected Total Depth: 3800'

Formation at Total Depth: Arbuckle

Water Source for Drilling Operations:

Well Farm Pond Other _____

DWR Permit #: per Div of Water Resources, permit not required

(Note: Apply for Permit with DWR)

Will Cores be taken? Yes No

If Yes, proposed zone: _____

* Oil & Gas Leases w/ pooling clauses attached

AFFIDAVIT

The undersigned hereby affirms that the drilling, completion and eventual plugging of this well will comply with K.S.A. 55 et. seq.
 It is agreed that the following minimum requirements will be met:

1. Notify the appropriate district office **prior** to spudding of well;
2. A copy of the approved notice of intent to drill **shall be** posted on each drilling rig;
3. The minimum amount of surface pipe as specified below **shall be set** by circulating cement to the top; in all cases surface pipe shall be set through all unconsolidated materials plus a minimum of 20 feet into the underlying formation.
4. If the well is dry hole, an agreement between the operator and the district office on plug length and placement is necessary **prior to plugging**;
5. The appropriate district office will be notified before well is either plugged or production casing is cemented in;
6. If an ALTERNATE II COMPLETION, production pipe shall be cemented from below any usable water to surface within **120 days** of spud date. Or pursuant to Appendix "B" - Eastern Kansas surface casing order #123,891-C, which applies to the KCC District 3 area, alternate II cementing must be completed within 30 days of the spud date or the well shall be plugged. **In all cases, NOTIFY district office** prior to any cementing.

I hereby certify that the statements made herein are true and to the best of my knowledge and belief.

Date: 8-16-2007 Signature of Operator or Agent: [Signature] Title: Vice-President

For KCC Use ONLY

API # 15 - 191-22516-0000
 Conductor pipe required None feet
 Minimum surface pipe required 250 feet per Alt. 1
 Approved by: [Signature] 8-21-07
 This authorization expires: 2-21-08
 (This authorization void if drilling not started within 6 months of approval date.)
 Spud date: _____ Agent: _____

Remember to:

- File Drill Pit Application (form CDP-1) with Intent to Drill;
- File Completion Form ACO-1 within 120 days of spud date;
- File acreage attribution plat according to field proration orders;
- Notify appropriate district office 48 hours prior to workover or re-entry;
- Submit plugging report (CP-4) after plugging is completed;
- Obtain written approval before disposing or injecting salt water.
- If this permit has expired (See: authorized expiration date) please check the box below and return to the address below.

Well Not Drilled - Permit Expired

Signature of Operator or Agent: _____
 Date: _____

Mail to: KCC - Conservation Division, 130 S. Market - Room 2078, Wichita, Kansas 67202

RECEIVED
 KANSAS CORPORATION COMMISSION

AUG 20 2007

CONSERVATION DIVISION
 WICHITA, KS

9
 35
 2E

IN ALL CASES PLOT THE INTENDED WELL ON THE PLAT BELOW

Plat of acreage attributable to a well in a prorated or spaced field

If the intended well is in a prorated or spaced field, please fully complete this side of the form. If the intended well is in a prorated or spaced field complete the plat below showing that the well will be properly located in relationship to other wells producing from the common source of supply. Please show all the wells and within 1 mile of the boundaries of the proposed acreage attribution unit for gas wells and within 1/2 mile of the boundaries of the proposed acreage attribution unit for oil wells.

API No. 15 - 191-22516-0000
 Operator: Sentinel Petroleum, Inc.
 Lease: Horton-McClaskey
 Well Number: 1
 Field: Murphy
 Number of Acres attributable to well: 10
 QTR / QTR / QTR of acreage: NW - SE - NE

Location of Well: County: Sumner
1650 feet from N / S Line of Section
990 feet from E / W Line of Section
 Sec. 9 Twp. 35S S. R. 2 East West

Is Section: Regular or Irregular

If Section is Irregular, locate well from nearest corner boundary.

Section corner used: NE NW SE SW

PLAT

(Show location of the well and shade attributable acreage for prorated or spaced wells.)

(Show footage to the nearest lease or unit boundary line.)

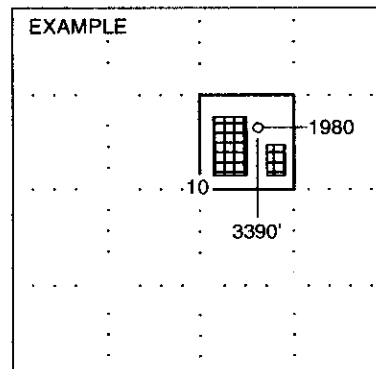
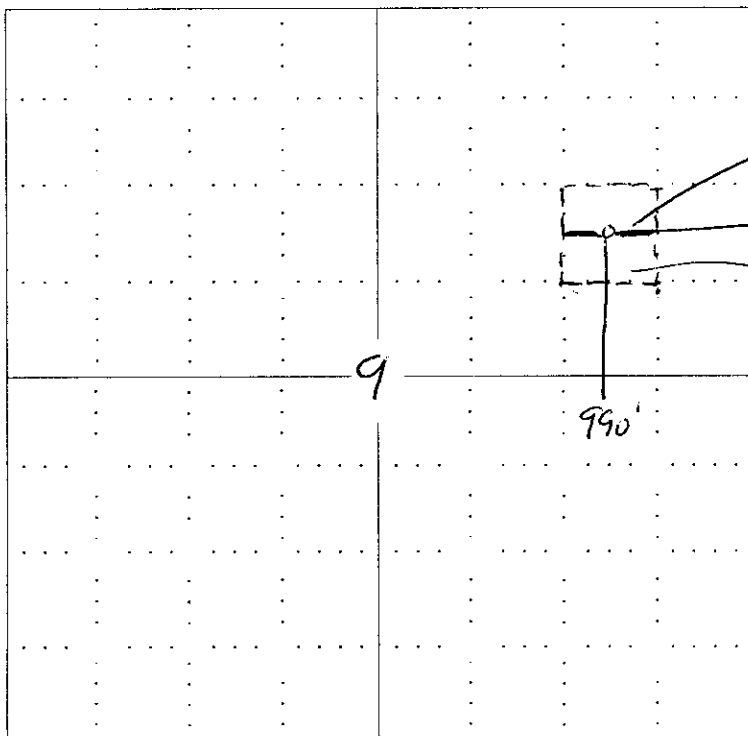

NOTE: In all cases locate the spot of the proposed drilling location.

RECEIVED
 KANSAS CORPORATION COMMISSION

AUG 20 2007

CONSERVATION DIVISION
 WICHITA, KS

In plotting the proposed location of the well, you must show:

1. The manner in which you are using the depicted plat by identifying section lines, i.e. 1 section, 1 section with 8 surrounding sections, 4 sections, etc.
2. The distance of the proposed drilling location from the section's south / north and east / west.
3. The distance to the nearest lease or unit boundary line.
4. If proposed location is located within a prorated or spaced field a certificate of acreage attribution plat must be attached: (C0-7 for oil wells; CG-8 for gas wells).

**KANSAS CORPORATION COMMISSION
OIL & GAS CONSERVATION DIVISION
APPLICATION FOR SURFACE PIT**

Form GDP-1
April 2004
Form must be Typed

Submit in Duplicate

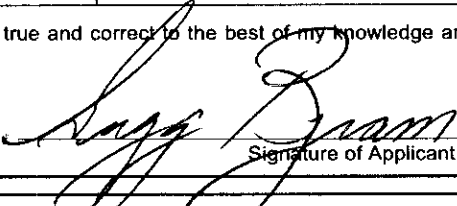
Operator Name: Sentinel Petroleum, Inc.		License Number: 33283
Operator Address: 101 N. Robinson, Suite 910, Oklahoma City, OK 73102		
Contact Person: Suzanne Rogers		Phone Number: (405) 239 - 2150
Lease Name & Well No.: Horton-McClaskey #1		Pit Location (QQQQ): NW SE NE
Type of Pit: <input type="checkbox"/> Emergency Pit <input type="checkbox"/> Burn Pit <input type="checkbox"/> Settling Pit <input checked="" type="checkbox"/> Drilling Pit <input type="checkbox"/> Workover Pit <input type="checkbox"/> Haul-Off Pit <small>(If WP Supply API No. or Year Drilled)</small>	Pit is: <input checked="" type="checkbox"/> Proposed <input type="checkbox"/> Existing If Existing, date constructed: _____ Pit capacity: 400 (bbls)	Sec. 9 Twp. 35S R. 2 <input checked="" type="checkbox"/> East <input type="checkbox"/> West 1650 Feet from <input checked="" type="checkbox"/> North / <input type="checkbox"/> South Line of Section 990 Feet from <input checked="" type="checkbox"/> East / <input type="checkbox"/> West Line of Section Sumner County
Is the pit located in a Sensitive Ground Water Area? <input type="checkbox"/> Yes <input checked="" type="checkbox"/> No		Chloride concentration: _____ mg/l <small>(For Emergency Pits and Settling Pits only)</small>
Is the bottom below ground level? <input checked="" type="checkbox"/> Yes <input type="checkbox"/> No	Artificial Liner? <input type="checkbox"/> Yes <input checked="" type="checkbox"/> No	How is the pit lined if a plastic liner is not used? Native Clay
Pit dimensions (all but working pits): 60 Length (feet) 60 Width (feet) _____ N/A: Steel Pits Depth from ground level to deepest point: 5 (feet)		
If the pit is lined give a brief description of the liner material, thickness and installation procedure.		Describe procedures for periodic maintenance and determining liner integrity, including any special monitoring.
Distance to nearest water well within one-mile of pit <input checked="" type="checkbox"/> N/A feet Depth of water well _____ feet		Depth to shallowest fresh water 22 feet. Source of information: _____ measured <input checked="" type="checkbox"/> well owner _____ electric log _____ KDWR
Emergency, Settling and Burn Pits ONLY: Producing Formation: _____ Number of producing wells on lease: _____ Barrels of fluid produced daily: _____ Does the slope from the tank battery allow all spilled fluids to flow into the pit? <input type="checkbox"/> Yes <input type="checkbox"/> No		Drilling, Workover and Haul-Off Pits ONLY: Type of material utilized in drilling/workover: premix/fresh water Number of working pits to be utilized: four (4) Abandonment procedure: evaporation & cover _____ Drill pits must be closed within 365 days of spud date.
I hereby certify that the above statements are true and correct to the best of my knowledge and belief.		RECEIVED KANSAS CORPORATION COMMISSION
Date 8-16-2007	Signature of Applicant or Agent 	AUG 20 2007 CONSERVATION DIVISION WICHITA, KS
KCC OFFICE USE ONLY		
Date Received: 8/20/07	Permit Number: _____	Permit Date: 8/20/07 Lease Inspection: <input type="checkbox"/> Yes <input checked="" type="checkbox"/> No

15-191-22516-0000

Mail to: KCC - Conservation Division, 130 S. Market - Room 2078, Wichita, Kansas 67202