

For KCC Use: 9-22-07
Effective Date: 3
District # 3
SGA? Yes No

KANSAS CORPORATION COMMISSION
OIL & GAS CONSERVATION DIVISION

Form C-1

December 2002

Form must be Typed

Form must be Signed

All blanks must be Filled

NOTICE OF INTENT TO DRILL

Must be approved by KCC five (5) days prior to commencing well

Expected Spud Date September 20, 2007
month day year

OPERATOR: License# 33344
Name: Quest Cherokee LLC
Address: 9520 North May Avenue, Suite 300
City/State/Zip: Oklahoma City, Oklahoma 73120
Contact Person: Richard Marlin
Phone: (405) 463-6880

CONTRACTOR: License# Will be licensed by the KCC
Name: Will advise on the ACO-1

Well Drilled For: Oil Gas QWOD Seismic; # of Holes Other Coalbed Methane
Well Class: Enh Rec Storage Disposal Wildcat Other
Type Equipment: Infield Pool Ext. Mud Rotary Air Rotary Cable

If OWWO: old well information as follows:
Operator: _____
Well Name: _____
Original Completion Date: _____ Original Total Depth: _____
Directional, Deviated or Horizontal wellbore? Yes No
If Yes, true vertical depth: _____
Bottom Hole Location: _____
KCC DKT #: _____

Spot N/2 SW NW Sec. 25 Twp. 27 S. R. 18 East West
1625 feet from N / S Line of Section
600 feet from E / W Line of Section
Is SECTION Regular Irregular?

(Note: Locate well on the Section Plat on reverse side)

County: Neosho
Lease Name: Parish, Wanda Well #: 25-1
Field Name: Cherokee Basin CBM
Is this a Prorated / Spaced Field? Yes No
Target Formation(s): Cherokee Coals
Nearest Lease or unit boundary: 600
Ground Surface Elevation: 947 feet MSL
Water well within one-quarter mile: Yes No
Public water supply well within one mile: Yes No
Depth to bottom of fresh water: 100
Depth to bottom of usable water: 200-150
Surface Pipe by Alternate: 1 2
Length of Surface Pipe Planned to be set: 25
Length of Conductor Pipe required: _____
Projected Total Depth: 1300
Formation at Total Depth: Cherokee Coals
Water Source for Drilling Operations: Well Farm Pond Other Air
DWR Permit #: _____
(Note: Apply for Permit with DWR)
Will Cores be taken? Yes No
If Yes, proposed zone: _____

AFFIDAVIT

RECEIVED
KANSAS CORPORATION COMMISSION

SEP 17 2007

CONSERVATION DIVISION
WICHITA, KS

The undersigned hereby affirms that the drilling, completion and eventual plugging of this well will comply with K.S.A. 55 et. seq.
It is agreed that the following minimum requirements will be met:
1. Notify the appropriate district office **prior** to spudding of well;
2. A copy of the approved notice of intent to drill **shall be** posted on each drilling rig;
3. The minimum amount of surface pipe as specified below **shall be set** by circulating cement to the top; in all cases surface pipe **shall be set** through all unconsolidated materials plus a minimum of 20 feet into the underlying formation.
4. If the well is dry hole, an agreement between the operator and the district office on plug length and placement is necessary **prior to plugging**;
5. The appropriate district office will be notified before well is either plugged or production casing is cemented in;
6. If an ALTERNATE II COMPLETION, production pipe shall be cemented from below any usable water to surface within **120 days** of spud date.
Or pursuant to Appendix "B" - Eastern Kansas surface casing order #133,891-C, which applies to the KCC District 3 area, alternate II cementing must be completed within 30 days of the spud date or the well shall be plugged. **In all cases, NOTIFY district office** prior to any cementing.
I hereby certify that the statements made herein are true and to the best of my knowledge and belief.

Date: September 13, 2007 Signature of Operator or Agent: [Signature] Title: VP

For KCC Use ONLY
API # 15 - 133-27168-0000
Conductor pipe required None feet
Minimum surface pipe required 20 feet per Alt. NO 2
Approved by: [Signature]
This authorization expires: 3-17-08
(This authorization void if drilling not started within 6 months of approval date.)
Spud date: _____ Agent: _____

Remember to:
- File Drill Pit Application (form CDP-1) with Intent to Drill;
- File Completion Form ACO-1 within 120 days of spud date;
- File acreage attribution plat according to field proration orders;
- Notify appropriate district office 48 hours prior to workover or re-entry;
- Submit plugging report (CP-4) after plugging is completed;
- Obtain written approval before disposing or injecting salt water.
- If this permit has expired (See: authorized expiration date) please check the box below and return to the address below.
 Well Not Drilled - Permit Expired
Signature of Operator or Agent: _____
Date: _____

Mail to: KCC - Conservation Division, 130 S. Market - Room 2078, Wichita, Kansas 67202

25
27
18E

IN ALL CASES PLOT THE INTENDED WELL ON THE PLAT BELOW

Plat of acreage attributable to a well in a prorated or spaced field

If the intended well is in a prorated or spaced field, please fully complete this side of the form. If the intended well is in a prorated or spaced field complete the plat below showing that the well will be properly located in relationship to other wells producing from the common source of supply. Please show all the wells and within 1 mile of the boundaries of the proposed acreage attribution unit for gas wells and within 1/2 mile of the boundaries of the proposed acreage attribution unit for oil wells.

API No. 15 - 133-271680000
 Operator: Quest Cherokee LLC
 Lease: Parish, Wanda
 Well Number: 25-1
 Field: Cherokee Basin CBM
 Number of Acres attributable to well: _____
 QTR / QTR / QTR of acreage: N/2 - SW - NW

Location of Well: County: Neosho
1625 feet from N / S Line of Section
600 feet from E / W Line of Section
 Sec. 25 Twp. 27 S. R. 18 East West
 Is Section: Regular or Irregular
If Section is Irregular, locate well from nearest corner boundary.
 Section corner used: NE NW SE SW

PLAT

*(Show location of the well and shade attributable acreage for prorated or spaced wells.)
 (Show footage to the nearest lease or unit boundary line.)*

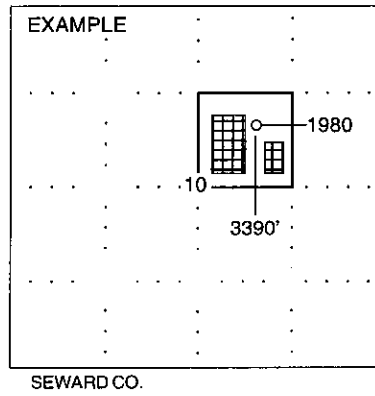
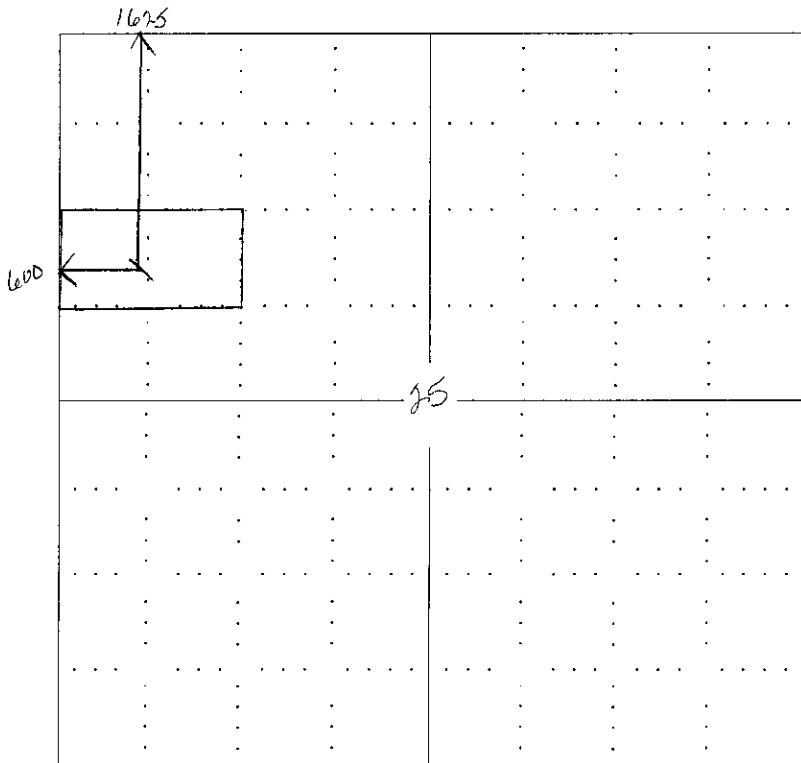

NOTE: In all cases locate the spot of the proposed drilling location.

In plotting the proposed location of the well, you must show:

1. The manner in which you are using the depicted plat by identifying section lines, i.e. 1 section, 1 section with 8 surrounding sections, 4 sections, etc.
2. The distance of the proposed drilling location from the section's south / north and east / west.
3. The distance to the nearest lease or unit boundary line.
4. If proposed location is located within a prorated or spaced field a certificate of acreage attribution plat must be attached: (CO-7 for oil wells; CG-8 for gas wells).

KANSAS CORPORATION COMMISSION
OIL & GAS CONSERVATION DIVISION

Form CDP-1
April 2004
Form must be Typed

APPLICATION FOR SURFACE PIT

Submit in Duplicate

Operator Name: Quest Cherokee LLC		License Number: 33344
Operator Address: 9520 North May Avenue, Suite 300 Oklahoma City, Oklahoma 73120		
Contact Person: Richard Marlin		Phone Number: (405) 463 - 6880
Lease Name & Well No.: Parish, Wanda #25-1		Pit Location (QQQQ): _____ N/2 _____ SW _____ NW Sec. 25 Twp. 27 R. 18 <input checked="" type="checkbox"/> East <input type="checkbox"/> West 1625 Feet from <input checked="" type="checkbox"/> North / <input type="checkbox"/> South Line of Section 600 Feet from <input type="checkbox"/> East / <input checked="" type="checkbox"/> West Line of Section Neosho _____ County
Type of Pit: <input type="checkbox"/> Emergency Pit <input type="checkbox"/> Burn Pit <input type="checkbox"/> Settling Pit <input checked="" type="checkbox"/> Drilling Pit <input type="checkbox"/> Workover Pit <input type="checkbox"/> Haul-Off Pit <small>(If WP Supply API No. or Year Drilled)</small>	Pit is: <input checked="" type="checkbox"/> Proposed <input type="checkbox"/> Existing If Existing, date constructed: _____ Pit capacity: 300 _____ (bbis)	
Is the pit located in a Sensitive Ground Water Area? <input type="checkbox"/> Yes <input checked="" type="checkbox"/> No		Chloride concentration: _____ mg/l <small>(For Emergency Pits and Settling Pits only)</small>
Is the bottom below ground level? <input type="checkbox"/> Yes <input checked="" type="checkbox"/> No	Artificial Liner? <input type="checkbox"/> Yes <input checked="" type="checkbox"/> No	How is the pit lined if a plastic liner is not used?
Pit dimensions (all but working pits): 30 _____ Length (feet) 10 _____ Width (feet) _____ N/A: Steel Pits Depth from ground level to deepest point: 10 _____ (feet)		
If the pit is lined give a brief description of the liner material, thickness and installation procedure.		Describe procedures for periodic maintenance and determining liner integrity, including any special monitoring. Air Drilling Operation lasting approx 3 days
Distance to nearest water well within one-mile of pit 5122 feet Depth of water well 80 feet		Depth to shallowest fresh water 18 feet. Source of information: _____ measured _____ well owner _____ electric log <input checked="" type="checkbox"/> KDWR
Emergency, Settling and Burn Pits ONLY: Producing Formation: _____ Number of producing wells on lease: _____ Barrels of fluid produced daily: _____ Does the slope from the tank battery allow all spilled fluids to flow into the pit? <input type="checkbox"/> Yes <input type="checkbox"/> No		Drilling, Workover and Haul-Off Pits ONLY: Type of material utilized in drilling/workover: Air Drilled Number of working pits to be utilized: One Abandonment procedure: Air Dry, Back Fill and Cover RECEIVED KANSAS CORPORATION COMMISSION Drill pits must be closed within 365 days of spud date. SEP 17 2007
I hereby certify that the above statements are true and correct to the best of my knowledge and belief. September 13, 2007 Date		CONSERVATION DIVISION WICHITA, KS <i>Richard Marlin</i> Signature of Applicant or Agent

15-133-27108-0000

KCC OFFICE USE ONLY			
Date Received: 9/12/07	Permit Number: _____	Permit Date: 9/17/07	Lease Inspection: <input type="checkbox"/> Yes <input checked="" type="checkbox"/> No

Mail to: KCC - Conservation Division, 130 S. Market - Room 2078, Wichita, Kansas 67202