

For KCC Use: 7-27-08  
 Effective Date: 3  
 District #: 3  
 SGA?  Yes  No

KANSAS CORPORATION COMMISSION  
 OIL & GAS CONSERVATION DIVISION

Form C-1

October 2007

Form must be Typed

Form must be Signed

All blanks must be Filled

**NOTICE OF INTENT TO DRILL**  
 Must be approved by KCC five (5) days prior to commencing well

Expected Spud Date: July 31, 2008  
 month day year

OPERATOR: License# 32955  
 Name: Kenneth & Regina Laymon, LLC  
 Address 1: 1998 Squirrel Road  
 Address 2:  
 City: Neosho Falls State: KS Zip: 66758 + 7124  
 Contact Person: Kenneth Laymon  
 Phone: 620-963-2495

CONTRACTOR: License# 5661  
 Name: Kelly Down Drilling Co., Inc

Well Drilled For:  Oil  Gas  Seismic  Other  
 Enh Rec  Storage  Disposal  
 # of Holes  
 Well Class:  Infield  Pool Ext.  Wildcat  Other  
 Type Equipment:  Mud Rotary  Air Rotary  Cable

If OWWO: old well information as follows:  
 Operator:  
 Well Name:  
 Original Completion Date: Original Total Depth:

Directional, Deviated or Horizontal wellbore?  Yes  No  
 If Yes, true vertical depth:  
 Bottom Hole Location:  
 KCC DKT #:

Spot Description:  
 SW SW NW Sec. 10 Twp. 24 S. R. 16  E  W  
 (2000) 3,090 feet from  N /  S Line of Section  
4,950 feet from  E /  W Line of Section

Is SECTION:  Regular  Irregular?  
 (Note: Locate well on the Section Plat on reverse side)

County: Woodson  
 Lease Name: Nusz Well #: 16-08  
 Field Name: Vernon

Is this a Prorated / Spaced Field?  Yes  No  
 Target Formation(s): Squirrel

Nearest Lease or unit boundary line (in footage): 3090  
 Ground Surface Elevation: n/a feet MSL

Water well within one-quarter mile:  Yes  No  
 Public water supply well within one mile:  Yes  No

Depth to bottom of fresh water: 125'  
 Depth to bottom of usable water: 150'

Surface Pipe by Alternate:  I  II  
 Length of Surface Pipe Planned to be set: 40'

Length of Conductor Pipe (if any): none  
 Projected Total Depth: 1150

Formation at Total Depth: Squirrel  
 Water Source for Drilling Operations:  
 Well  Farm Pond  Other:

DWR Permit #: (Note: Apply for Permit with DWR)

Will Cores be taken?  Yes  No  
 If Yes, proposed zone:

**AFFIDAVIT**

RECEIVED  
 KANSAS CORPORATION COMMISSION

JUL 21 2008

CONSERVATION DIVISION  
 WICHITA, KS

The undersigned hereby affirms that the drilling, completion and eventual plugging of this well will comply with K.S.A. 55 et. seq.  
 It is agreed that the following minimum requirements will be met:

1. Notify the appropriate district office **prior** to spudding of well;
2. A copy of the approved notice of intent to drill **shall be** posted on each drilling rig;
3. The minimum amount of surface pipe as specified below **shall be set** by circulating cement to the top; in all cases surface pipe **shall be set** through all unconsolidated materials plus a minimum of 20 feet into the underlying formation.
4. If the well is dry hole, an agreement between the operator and the district office on plug length and placement is necessary **prior to plugging**;
5. The appropriate district office will be notified before well is either plugged or production casing is cemented in;
6. If an ALTERNATE II COMPLETION, production pipe shall be cemented from below any usable water to surface within **120 DAYS** of spud date.  
 Or pursuant to Appendix "B" - Eastern Kansas surface casing order #133,891-C, which applies to the KCC District 3 area, alternate II cementing must be completed within 30 days of the spud date or the well shall be plugged. **In all cases, NOTIFY district office** prior to any cementing.

I hereby certify that the statements made herein are true and correct to the best of my knowledge and belief.

Date: 7/16/08 Signature of Operator or Agent: Regina Laymon Title: Agnt.

**For KCC Use ONLY**  
 API # 15 - 207-27417-0000  
 Conductor pipe required None feet  
 Minimum surface pipe required 50 feet per ALT  I  II  
 Approved by: puth 7-22-08  
 This authorization expires: 7-22-09  
 (This authorization void if drilling not started within 12 months of approval date.)  
 Spud date: Agent:

**Remember to:**

- File Drill Pit Application (form CDP-1) with Intent to Drill;
- File Completion Form ACO-1 within 120 days of spud date;
- File acreage attribution plat according to field proration orders;
- Notify appropriate district office 48 hours prior to workover or re-entry;
- Submit plugging report (CP-4) after plugging is completed (within 60 days);
- Obtain written approval before disposing or injecting salt water.

If this permit has expired (See: authorized expiration date) please check the box below and return to the address below.  
 Well Not Drilled - Permit Expired Date: Signature of Operator or Agent:

10  
24  
16  
 E  W

**IN ALL CASES PLOT THE INTENDED WELL ON THE PLAT BELOW**

*Plat of acreage attributable to a well in a prorated or spaced field*

**If the intended well is in a prorated or spaced field, please fully complete this side of the form.** If the intended well is in a prorated or spaced field complete the plat below showing that the well will be properly located in relationship to other wells producing from the common source of supply. Please show all the wells and within 1 mile of the boundaries of the proposed acreage attribution unit for gas wells and within 1/2 mile of the boundaries of the proposed acreage attribution unit for oil wells.

API No. 15 207-27417-0000  
 Operator: Kenneth & Regina Laymon, LLC  
 Lease: Nusz  
 Well Number: 16-08  
 Field: Vernon

Location of Well: County: Woodson  
 3,090 feet from  N /  S Line of Section  
 4,950 feet from  E /  W Line of Section  
 Sec. 10 Twp. 24 S. R. 16  E  W

Number of Acres attributable to well: \_\_\_\_\_  
 QTR/QTR/QTR/QTR of acreage: SW - SW - NW - \_\_\_\_\_

Is Section:  Regular or  Irregular

**If Section is Irregular, locate well from nearest corner boundary.**  
 Section corner used:  NE  NW  SE  SW

**PLAT**

*(Show location of the well and shade attributable acreage for prorated or spaced wells.)  
 (Show footage to the nearest lease or unit boundary line.)*

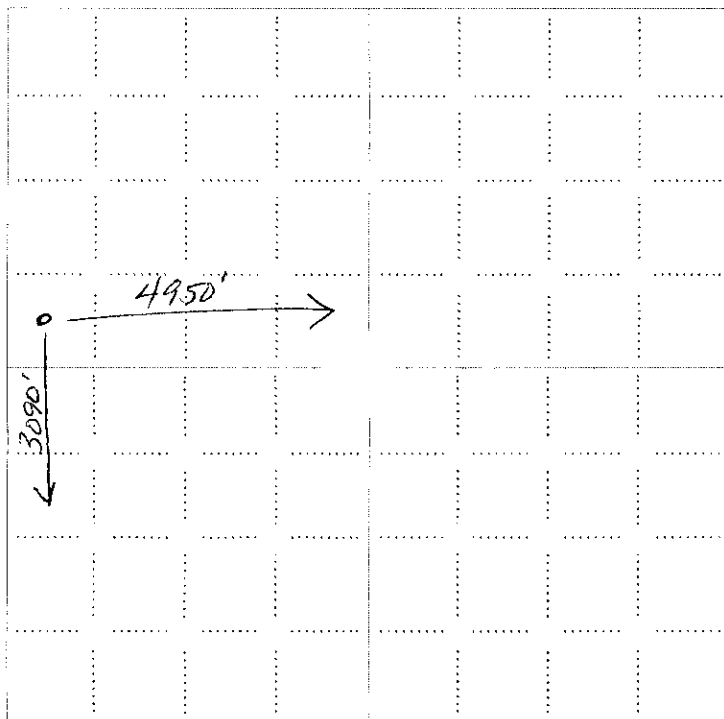

RECEIVED  
 KANSAS CORPORATION COMMISSION  
 JUL 21 2008  
 CONSERVATION DIVISION  
 WICHITA, KS

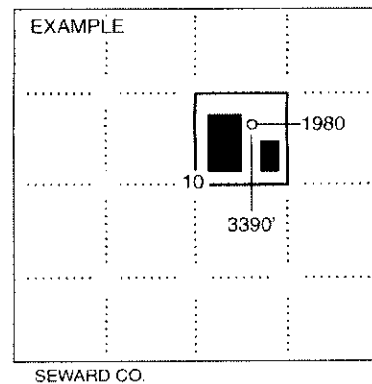

**NOTE: In all cases locate the spot of the proposed drilling locaton.**

**In plotting the proposed location of the well, you must show:**

1. The manner in which you are using the depicted plat by identifying section lines, i.e. 1 section, 1 section with 8 surrounding sections, 4 sections, etc.
2. The distance of the proposed drilling location from the south / north and east / west outside section lines.
3. The distance to the nearest lease or unit boundary line (in footage).
4. If proposed location is located within a prorated or spaced field a certificate of acreage attribution plat must be attached: (C0-7 for oil wells; CG-8 for gas wells).

KANSAS CORPORATION COMMISSION  
OIL & GAS CONSERVATION DIVISION  
APPLICATION FOR SURFACE PIT

Form CDP-1  
April 2004  
Form must be Typed

Submit in Duplicate

Operator Name: <b>Kenneth &amp; Regina Laymon, LLC</b>		License Number: <b>32955</b>
Operator Address: <b>1998 Squirrel Road</b>		<b>Neosho Falls KS 66758</b>
Contact Person: <b>Kenneth Laymon</b>		Phone Number: <b>620-963-2495</b>
Lease Name & Well No.: <b>Nusz 16-08</b>		Pit Location (QQQQ): <b>SE SW NW NW</b> Sec. <b>10</b> Twp. <b>24</b> R. <b>16</b> <input checked="" type="checkbox"/> East <input type="checkbox"/> West 3,090 Feet from <input type="checkbox"/> North / <input checked="" type="checkbox"/> South Line of Section 4,950 Feet from <input checked="" type="checkbox"/> East / <input type="checkbox"/> West Line of Section <b>Woodson</b> County
Type of Pit: <input type="checkbox"/> Emergency Pit <input type="checkbox"/> Burn Pit <input type="checkbox"/> Settling Pit <input checked="" type="checkbox"/> Drilling Pit <input type="checkbox"/> Workover Pit <input type="checkbox"/> Haul-Off Pit <i>(If WP Supply API No. or Year Drilled)</i>	Pit is: <input checked="" type="checkbox"/> Proposed <input type="checkbox"/> Existing If Existing, date constructed: Pit capacity: <b>240</b> (bbls)	
Is the pit located in a Sensitive Ground Water Area? <input type="checkbox"/> Yes <input checked="" type="checkbox"/> No		Chloride concentration: _____ mg/l <i>(For Emergency Pits and Settling Pits only)</i>
Is the bottom below ground level? <input checked="" type="checkbox"/> Yes <input type="checkbox"/> No	Artificial Liner? <input type="checkbox"/> Yes <input checked="" type="checkbox"/> No	How is the pit lined if a plastic liner is not used? <b>Native clay</b>
Pit dimensions (all but working pits): <b>50</b> Length (feet) <b>8</b> Width (feet) <input type="checkbox"/> N/A: Steel Pits Depth from ground level to deepest point: <b>4</b> (feet) <input type="checkbox"/> No Pit		
If the pit is lined give a brief description of the liner material, thickness and installation procedure.		Describe procedures for periodic maintenance and determining liner integrity, including any special monitoring. <b>RECEIVED</b> KANSAS CORPORATION COMMISSION <b>JUL 21 2008</b> CONSERVATION DIVISION WICHITA, KS
Distance to nearest water well within one-mile of pit <b>N/A</b> feet Depth of water well _____ feet		Depth to shallowest fresh water _____ feet. Source of information: <input type="checkbox"/> measured <input type="checkbox"/> well owner <input type="checkbox"/> electric log <input type="checkbox"/> KDWR
<b>Emergency, Settling and Burn Pits ONLY:</b> Producing Formation: _____ Number of producing wells on lease: _____ Barrels of fluid produced daily: _____ Does the slope from the tank battery allow all spilled fluids to flow into the pit? <input type="checkbox"/> Yes <input type="checkbox"/> No		<b>Drilling, Workover and Haul-Off Pits ONLY:</b> Type of material utilized in drilling/workover: <b>drilling gel</b> Number of working pits to be utilized: <b>1</b> Abandonment procedure: <b>backfill w/dirt</b> Drill pits must be closed within 365 days of spud date.
I hereby certify that the above statements are true and correct to the best of my knowledge and belief.  July 16, 2008 Date <b>Regina Laymon, Agent</b> Signature of Applicant or Agent		
<b>KCC OFFICE USE ONLY</b> Steel Pit <input type="checkbox"/> RFAC <input type="checkbox"/> RFAS <input type="checkbox"/>		
Date Received: <b>7/21/08</b> Permit Number: _____ Permit Date: <b>7/21/08</b> Lease Inspection: <input type="checkbox"/> Yes <input checked="" type="checkbox"/> No		

Mail to: KCC - Conservation Division, 130 S. Market - Room 2078, Wichita, Kansas 67202

15-207-27417-0000