

KANSAS CORPORATION COMMISSION
OIL & GAS CONSERVATION DIVISION

Form CP-1
September 2003
Form must be Typed
Form must be Signed
All blanks must be Filled

WELL PLUGGING APPLICATION

Please TYPE Form and File ONE Copy

API # 15- 187-20191 -00-00 (Identifier Number of this well). This must be listed for wells drilled since 1967; if no API # was issued.

Indicate original spud or completion date S 7/20/75 C 8/26/75

Well Operator: BP AMERICA PRODUCTION COMPANY KCC License #: 5952

Address: P. O. BOX 3092, RM 6.128, WL1 City: HOUSTON
(Owner/Company Name) (Operator's)

State: TEXAS Zip Code: 77253-3092 Contact Phone: 281 366-4395

Lease: BAUGHMAN GAS UNIT E Well #: 2 Sec. 6 Twp. 30 R. 39 East West

nene sesw KCC PPT
e s2 Spot Location/QQQQ County STANTON

1250 Feet from (in exact footage) North / South (from nearest outside section corner) Line of Section (not Lease Line)

2950 Feet from (in exact footage) East / West (from nearest outside section corner) Line of Section (not Lease Line)

Check One: Oil Well Gas Well D&A Cathodic Water Supply Well
 SWD Docket # _____ ENHR Docket # _____ Other _____

Conductor Casing Size: _____ Set at: _____ Cemented with: _____ Sacks

Surface Casing Size: 8 - 5/8" Set at: 608' Cemented with: 400 Sacks

Production Casing Size: 5 - 1/2" Set at: 2771' Cemented with: 800 Sacks

List (ALL) Perforations and Bridgeplug Sets: Perfs: 2577'-2692' CIBP: 1500'

Elevation: 3221' (G.L. K.B.) T.D. 2771' PBDT 2754' Anhydrite Depth _____
(Stone Corral Formation)

Condition of Well: Good Poor Casing Leak Junk in Hole

Proposed Method of Plugging (attach a separate page if additional space is needed): SEE ATTACHED PROCEDURE

RECEIVED
KANSAS CORPORATION COMMISSION

Is Well Log attached to this application as required? Yes No Is ACO-1 filed? Yes No

OCT 21 2008

If not explain why? _____ CONSERVATION DIVISION
WICHITA, KS

Plugging of this Well will be done in accordance with K.S.A. 55-101 et. seq. and the Rules and Regulations of the State Corporation Commission

List Name of Company Representative authorized to be in charge of plugging operations:

DEANN SMYERS Phone: 281 366-4395

Address: P. O. BOX 3092, RM 6.128, WL1 City/State HOUSTON, TEXAS 77253-3092

Plugging Contractor ORR ENTERPRISES, INC. KCC License # 33338
(Company Name) (Contractor's)

Address BOX 1706 DUNCAN, OK 73534 Phone: 580 467-0258

Proposed Date and Hour of Plugging (if known?): _____

Payment of the Plugging Fee (K.A.R. 82-3-118) will be guaranteed by Operator or Agent

Date: 10/15/2008 Authorized Operator / Agent: DeAnn Smyers
(Signature)

Dust 1
Pkt

Plugging Application
Baughman E 2 - Abandonment
Sec 6, T30S, R39W
Stanton County, Kansas

The application attached is to abandon the Baughman E 2. BP is abandoning this well as it has become uneconomic to operate.

RECEIVED
KANSAS CORPORATION COMMISSION

OCT 21 2008

CONSERVATION DIVISION
WICHITA, KS

**Plugging Procedure for the Baughman E 2
Section 6 T30S R39W
Stanton County, Kansas**

NOTE – NOTIFY KCC DISTRICT OFFICE AT LEAST FIVE DAYS IN ADVANCE OF WORK.

This procedure was approved via email between Joe Eudey (BP representative) and Steve Durant (KCC) on October 1, 2008.

PLANNED PLUGGING PROCEDURE

1. Set CIBP at 1500'
2. TIH with tubing and set above CIBP
3. Mix and pump cement down 2-3/8" tubing until cement circulates. Cement to be Halliburton 40/60 poz with 4% gel mixed at 13.5 ppg with a yield of 1.54 cuft/sk. This should take 200 sacks including 50% excess.
4. TOH with tubing. Top off 5-1/2" casing with cement
5. Have 50 extra sacks of cement on location to fill the 8-5/8" X 5-1/2" annulus.
6. Cut off and cap the casing 5' below ground level
7. Restore the location

**RECEIVED
KANSAS CORPORATION COMMISSION**

OCT 21 2008

**CONSERVATION DIVISION
WICHITA, KS**

Baughman E 2
Section 6, T30S, R39W
Council Grove Formation
Panoma Field
Stanton County, Kansas

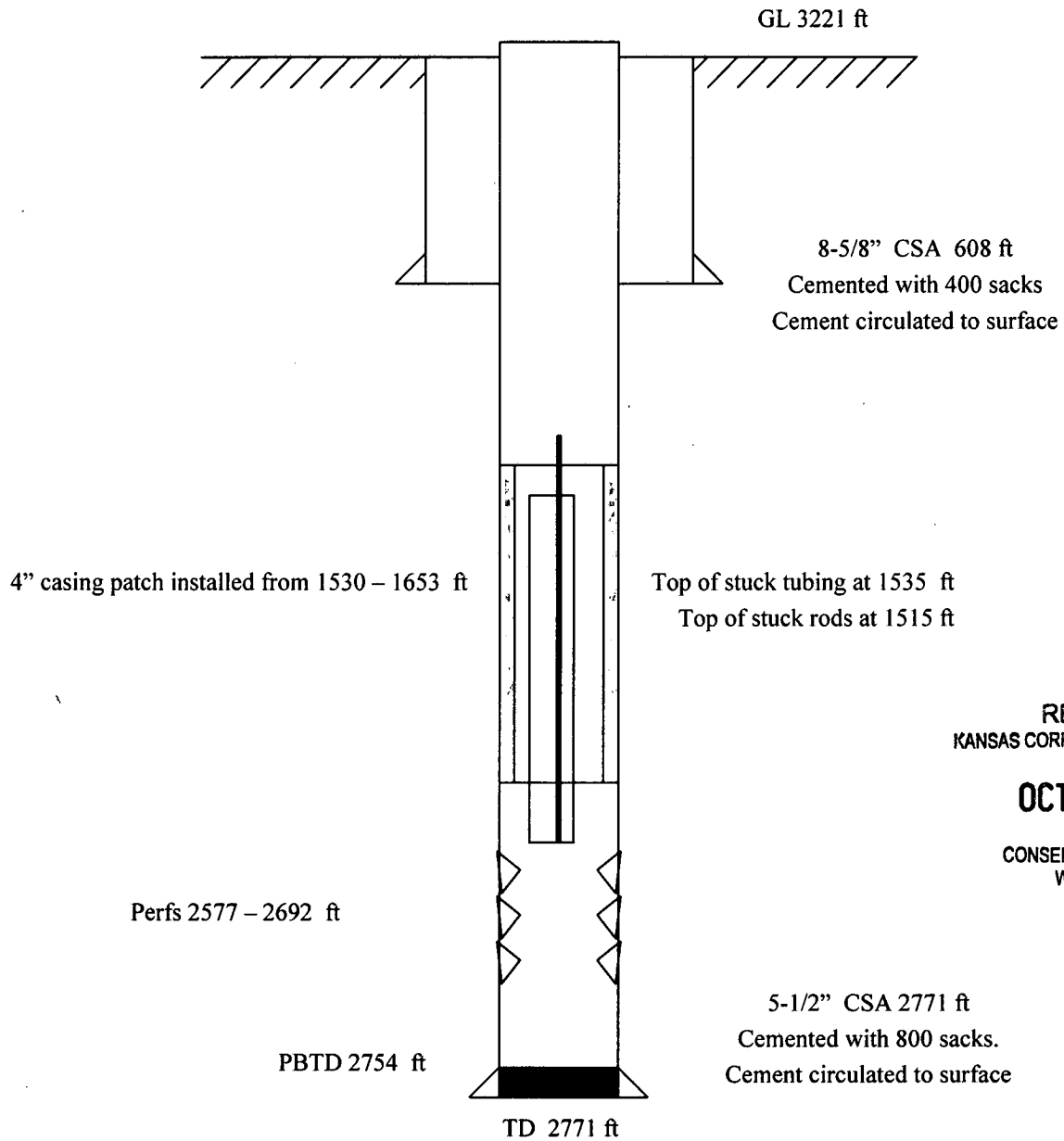

RECEIVED
KANSAS CORPORATION COMMISSION

OCT 21 2008

CONSERVATION DIVISION
WICHITA, KS

Not to scale

Baughman E 2
Section 6, T30S, R39W
Council Grove Formation
Panoma Field
Stanton County, Kansas

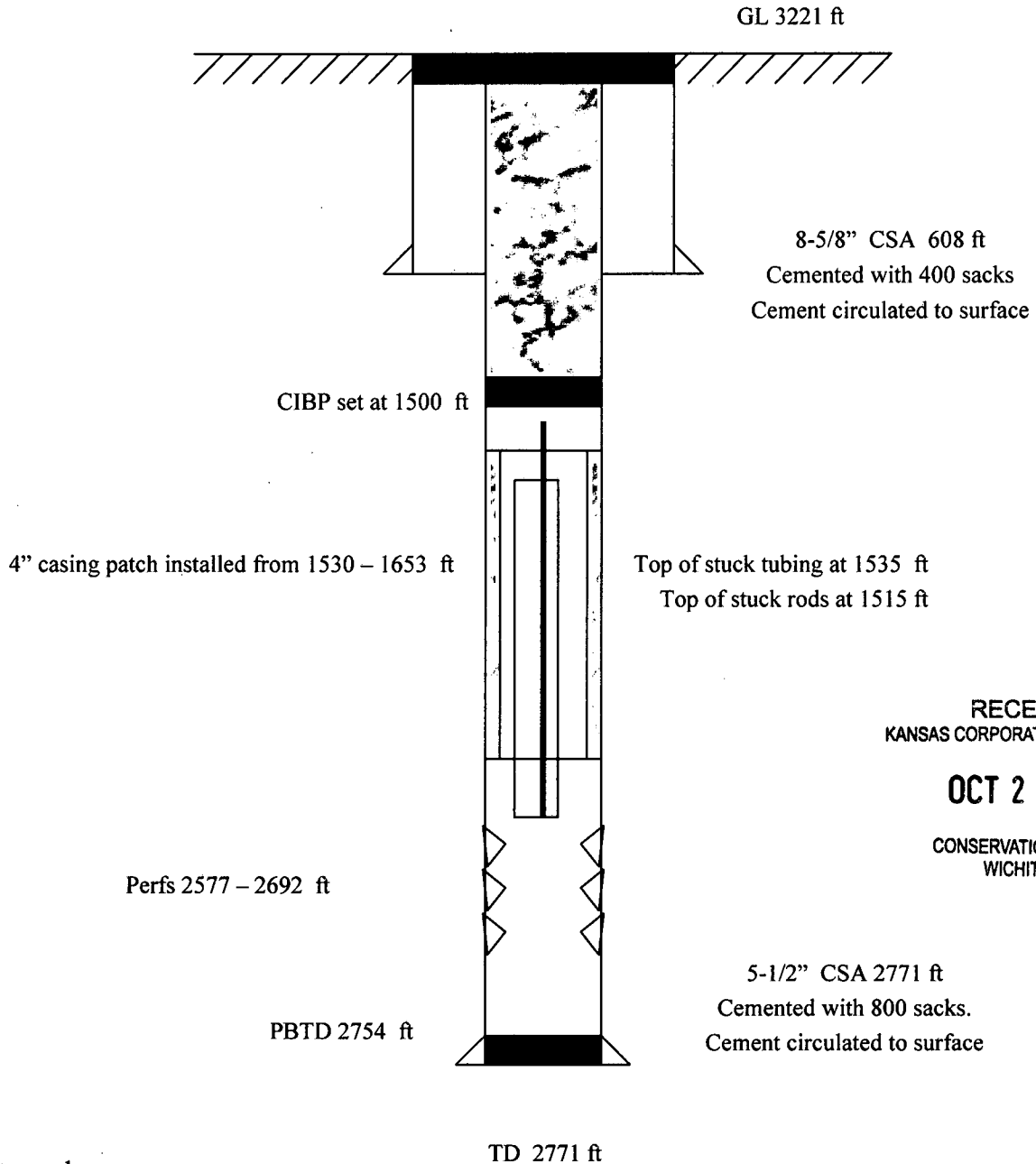



CORPORATION COMMISSION

Kathleen Sebelius, Governor Thomas E. Wright, Chairman Michael C. Moffet, Commissioner Joseph F. Harkins, Commissioner

NOTICE OF RECEIPT OF WELL PLUGGING APPLICATION (CP-1)

BP AMERICA PRODUCTION COMPANY
2225 W OKLAHOMA AVE
ULYSSES, KS 67880-8416

October 28, 2008

Re: BAUGHMAN GUE #2
API 15-187-20191-00-00
6-30S-39W, 1250 FSL 2950 FEL
STANTON COUNTY, KANSAS

Dear Operator:

This letter is to notify you that the Conservation Division has received your plugging proposal, form CP-1, for the above well and has reviewed the proposal for completeness. The central office will now forward your CP-1 to the district office listed below for review of the proposed plugging method. **Please contact the district office for approval of your proposed plugging method at least five (5) days before plugging the well, pursuant to K.A.R. 82-3-113(b). If a workover pit will be used during the plugging of the well it must be permitted. A CDP-1 form must be filed and approved prior to the use of the pit in accordance with K.A.R. 82-3-600.**

The Conservation Division's review of form CP-1, either in the central or district office, does not include an inquiry into well ownership or the filing operator's legal right to plug the well. This notice in no way constitutes authorization to plug the above well by persons not having legal rights of ownership or interest in the well.

This notice is void after April 26, 2009. The CP-1 filing does not bring the above well into compliance with K.A.R. 82-3-111 with regard to the Commission's temporary abandonment requirements.

Sincerely,

Steve Bond
Production Department Supervisor

District: #1
210 E Frontview, Suite A
Dodge City, KS 67801
(620) 225-8888