

**KANSAS CORPORATION COMMISSION  
OIL & GAS CONSERVATION DIVISION  
WELL PLUGGING APPLICATION**  
Please TYPE Form and File ONE Copy

Form CP-1  
September 2003  
**This Form must be Typed  
Form must be Signed  
All blanks must be Filled**

API # 15-167-20821-00-00 (Identifier Number of this well). This must be listed for wells drilled since 1967; if no API # was issued, indicate original spud or completion date \_\_\_\_\_.

Well Operator: Mike Kelso Oil, Inc. (Owner / Company Name) KCC License #: 31728 <sup>5</sup> (Operator's)

Address: P.O. Box 467 City: Chase

State: Kansas Zip Code: 67524 Contact Phone: ( 620 ) 938 - 2943

Lease: Jacobs Well #: 1 Sec. 22 Twp. 14 S. R. 15  East  West

Sese - NW/4 Spot Location / QQQQ County: Russell

3017 Feet (in exact footage) From  North /  South (from nearest outside section corner) Line of Section (Not Lease Line)

2989 Feet (in exact footage) From  East /  West (from nearest outside section corner) Line of Section (Not Lease Line)

Check One:  Oil Well  Gas Well  D&A  Cathodic  Water Supply Well  
 SWD Docket # D24964  ENHR Docket # \_\_\_\_\_  Other: \_\_\_\_\_

Conductor Casing Size: \_\_\_\_\_ Set at: \_\_\_\_\_ Cemented with: \_\_\_\_\_ Sacks

Surface Casing Size: 10-3/4" Set at: 218' Cemented with: 140 sxs. Sacks

Production Casing Size: 7" Set at: 3288' Cemented with: 150sxs. Sacks

List (ALL) Perforations and Bridgeplug Sets: Squeezed @852' w/300 sxs. cemented to surface.

Elevation: \_\_\_\_\_ (  G.L. /  K.B. ) T.D.: 3458 PBTD: \_\_\_\_\_ Anhydrite Depth: \_\_\_\_\_ (Stone Corral Formation)

Condition of Well:  Good  Poor  Casing Leak  Junk in Hole

Proposed Method of Plugging (attach a separate page if additional space is needed): Per KCC Instructions

**RECEIVED**  
**KANSAS CORPORATION COMMISSION**  
**JAN 26 2009**  
**CONSERVATION DIVISION**  
**WICHITA, KS**

Is Well Log attached to this application as required?  Yes  No Is ACO-1 filed?  Yes  No

If not explain why? Unavailable

**Plugging of this Well will be done in accordance with K.S.A. 55-101 et. seq. and the Rules and Regulations of the State Corporation Commission.**

List Name of Company Representative authorized to be in charge of plugging operations: \_\_\_\_\_

Mike Kelso Phone: ( 620 ) 562 - 8088

Address: P.O. Box 467 City / State: Chase, Kansas 67524

Plugging Contractor: Mike's Testing & Salvage, Inc. (Company Name) KCC License #: 31529

Address: P.O. Box 467 Chase, Kansas 67524 Phone: ( 620 ) 938 - 2943 (Contractor's)

Proposed Date and Hour of Plugging (if known?): 1-23-09 1:30 Pm

Payment of the Plugging Fee (K.A.R. 82-3-118) will be guaranteed by Operator or Agent

Date: 1-23-09 Authorized Operator / Agent: [Signature] (Signature)

Mail to: KCC - Conservation Division, 130 S. Market - Room 2078, Wichita, Kansas 67202

\* well plugged - KCC - PKT

Dist 4  
PKT

Mailed to D. Lewis 2-3-87

State of Kansas



JOHN CARLIN  
MICHAEL LENNEN  
MARGALEE WRIGHT  
KEITH R. HENLEY  
JUDITH A. McCONNELL  
BRIAN J. MOLINE

Governor  
Chairman  
Commissioner  
Commissioner  
Executive Secretary  
General Counsel

State Corporation Commission  
CONSERVATION DIVISION

(Oil, Gas and Water)  
200 Colorado Derby Building  
202 West 1st Street  
WICHITA, KANSAS 67202-1286  
Ph. 316-263-3238

January 29, 1987

Harold Hillenburg Oil  
11600 S. Lynn Lane Rd.  
Broken Arrow, Oklahoma 74011

Application for Injection Well  
Lease Jacobs Well # 1 SWD  
Legal NW/4 22-14-15W  
County Russell

Dear Sirs:

The following information is needed in order to continue processing this application:

       A better map. Maps are required to show the following: township, range, appropriate section numbers, the applicant injection well, all producing wells, abandoned wells, plugged holes, and other wells within a half mile radius, lease boundaries, lease operators, wells numbers and producing wells producing formation tops.

Verification of cementing. (ie, completion report, cementing ticket, bond log, etc.) Cement ticket on perf. and squeeze @ 812'

       Proper notice. Notice must be mailed or delivered to the landowner on whose land the injection well is located, and each operator of a producing leasehold and each unleased mineral rights owner within 1/2 mile of the well.

       Some type of log. (drillers log or electric log)

       Other \_\_\_\_\_

RECEIVED  
KANSAS CORPORATION COMMISSION

JAN 26 2009

CONSERVATION DIVISION  
WICHITA, KS

As soon as I receive this information, I can continue to process this application. Thank you for your cooperation in this matter.

Sincerely,

\_\_\_\_\_  
Doug Louis  
Geologist, UIC Section

cc: District Office # 6

*KAW*

WELL NO. AND FARM <b>1 Jacob SWD</b>	COUNTY <b>Russell</b>	STATE <b>Kansas</b>	DATE <b>1-21-76</b>
OWNER <b>Hillenburg Pipe Supply Co.</b>	CONTRACTOR	DUNCAN USE ONLY	
CHARGE TO ADDRESS <b>Same: 116 St. South Lynn Lane Rd Broken Arrow, Okla. 74012</b>	DELIVERED TO SHIPPED VIA	LOCATION <b>1 Hays, Ks. 50325</b>	CODE <b>50325</b>
DUNCAN USE ONLY <b>HILLENBURG PIPE &amp; SUPPLY 3 116TH ST. &amp; SO LYNN LANE RD. BROKEN ARROW, OKLA 74012 A</b>	CUST. INV. REQ. ORIG. & <input type="checkbox"/> 1 <input type="checkbox"/> 2 <input type="checkbox"/> 3 <input type="checkbox"/> 4	REQUISITION ORDER NO.	LOCATION <b>2</b>
			LOCATION <b>3</b>
		TOTAL ACID - 30 DAYS	BULK MATERIAL DELIVERY TICKET NO. <b>B-407350</b>
		NO. COPIES	WELL TYPE <b>Discard</b>
TERMS: <b>NET</b>		DUE BY THE 20TH OF FOLLOWING MONTH. INTEREST CHARGED AFTER 60 DAYS FROM DATE OF INVOICE.	
		TYPE AND PURPOSE OF JOB <b>(New Well) C-C. Cement</b>	

PRICE REFERENCE	SECONDARY REF. OR PART NO.	CODE L D	DESCRIPTION	UNITS 1		UNITS 2		UNIT PRICE	AMOUNT	
				QTY.	MEAS.	QTY.	MEAS.			
201-016		1C	Pump Service	847	FT.				424	10
200-117		1C	Mileage F/Russell	11	mi.			1.10	12	10
236-502		1C	Wooden Top Plug	1	Ed.	7"			17	55
219-000		1C	SLM Temp. Survey	1					125	00
504-118		1B	C.C. FT. HLC	150				2.40	360	00
504-043		1B	Regular Portland	50				2.74	137	00
			SERVICE CHARGE ON MATERIALS RETURNED		CU. FT.					
500-207		1B	SERVICE CHARGE	500	CU. FT.			55	110	00
500-306		1B	TOTAL WEIGHT 11	18,530	TON	LOADED MILES 101.92		1.35	35	67

RECEIVED  
KANSAS CORPORATION COMMISSION  
**JAN 26 2009**  
CORPORATION DIVISION  
WICHITA, KS

**TAX REFERENCES**

SUB TOTAL  
**NO TAX**  
TAX  
TAX  
TOTAL **1221 42**

WAS JOB SATISFACTORILY COMPLETED?  
WAS OPERATION OF EQUIPMENT SATISFACTORY?  
WAS PERFORMANCE OF PERSONNEL SATISFACTORY?  
X *H.A. Hillenburg, Jr.*  
Customer or His Agent

*Ralph A. Tappan*  
Halliburton Operator

APPROVED *J.B. McCall*  
DIVISION MANAGER

**L-K Wireline**

1011 East Hiway 40 By-pass - Hays, Kansas 67601  
Phone 913 625-6877

INVOICE NO. 777

Date 1/21/76

CHARGE TO:

HILLENBURG OIL COMPANY  
116th STREET SOUTH LYNN LANE ROAD  
BROKEN ARROW, OKLAHOMA 74012

CUSTOMER  
ORDER NO. \_\_\_\_\_

TERMS: NET 30 DAYS

JOB DATE 1/21/76 LEASE JACOBS SWDW SEC. 22 TWP 14S RANGE 15W  
KIND OF JOB PERFORATING FIELD \_\_\_\_\_ COUNTY RUSSELL STATE KANSAS

TICKET NO.	DESCRIPTION	AMOUNT
777	PERFORATE FOR SQUEEZE @ 852'	\$ 425.00
		\$ 425.00
	NEW WELL --- NO SALES TAX	

RECEIVED  
KANSAS CORPORATION COMMISSION

JAN 26 2009

CONSERVATION DIVISION  
WICHITA, KS

- (2) Because of the uncertain conditions existing in a well, it is understood by the customer that L-K Wireline cannot guarantee the results of their services and will not be held responsible for personal or property damage in the performances of their services.
- (3) Should any L-K Wireline instruments be lost or damaged in the performance of the operations requested, the customer agrees to make every reasonable effort to recover same, and to reimburse L-K Wireline, for the value of the items which cannot be recovered, or the cost of repairing damage to items recovered.
- (4) It is further understood and agreed that all depth measurements shall be supervised by the customer or its employees, and customer hereby certifies that the zones, as shot were approved.
- (5) The customer certifies that it has the full right and authority to order such work on such well and that the well in which the work is to be done by L-K Wireline is in proper and suitable condition for the performances of said work.
- (6) No employee is authorized to alter the terms or conditions of this agreement.



Jacobs #1

July

7-10-80

Run 121' of 1" between  
surface & long string  
& pumped full of  
Cement.

Run 3"  ~~tubing~~ fiber  
glass to bottom &  
acidized well with  
5000 gal 15%.

RECEIVED  
KANSAS CORPORATION COMMISSION

JAN 26 2009

CONSERVATION DIVISION  
WICHITA, KS

WELL COMPLETION

TYPE: Tubing & packer / /; Packerless (tubing) / X /; Tubingless / /

CASING OR TUBING	CONDUCTOR	SURFACE	INTERMEDIATE	PRODUCTION	TUBING
SIZE		10-3/4	2nd stage	7"	3-1/2"
SETTING DEPTH		218	812	3288	3302
CEMENT SACKS		140	200 + 110	150	
CEMENT: TOPS		0	0	2190	
CEMENT: BOTTOMS		218	812	3288	

TUBING: TYPE 3-1/2" Fiberglass GRADE \_\_\_\_\_

PACKER: TYPE NA DEPTH \_\_\_\_\_

ANNULUS CORROSION INHIBITION FLUID: TYPE Diesel fuel CONCENTRATION \_\_\_\_\_

LIST LOGS ENCLOSED:

Drillers Log  
Temperature Survey

RECEIVED  
KANSAS CORPORATION COMMISSION

JAN 26 2009

CONSERVATION DIVISION  
WICHITA, KS

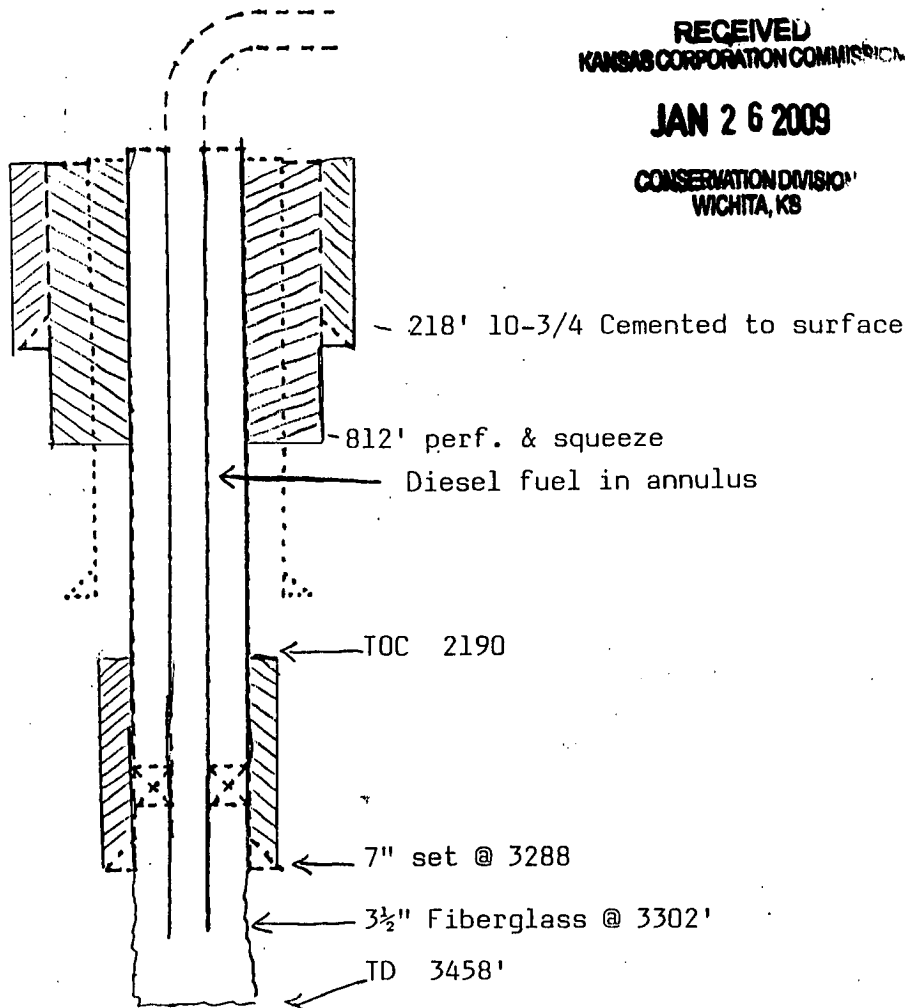

Static water level is 700 feet below surface.

(To sketch installation, darken appropriate lines, indicate cement, and show depths.)

NOTE: Page 4 must be completed on all applications.