

RECEIVED

AUG 02 2010

Form C-1
March 2010

For KCC Use: 8-22-2010
Effective Date: 3
District # 3
SGA? Yes No

KANSAS CORPORATION COMMISSION
OIL & GAS CONSERVATION DIVISION

Form must be Typed
Form must be Signed
All blanks must be Filled

NOTICE OF INTENT TO DRILL KCC WICHITA

Must be approved by KCC five (5) days prior to commencing well

Form KSONA-1, Certification of Compliance with the Kansas Surface Owner Notification Act, MUST be submitted with this form.

Expected Spud Date: AUGUST 9, 2010
month day year

OPERATOR: License# 5556
Name: VIVA INTERNATIONAL, INC
Address 1: 8357 MELROSE DRIVE
Address 2: _____
City: LENEXA State: KS Zip: 66214
Contact Person: ROBERT P BUKATY
Phone: 913-859-0438

CONTRACTOR: License# 33734
Name: HAT DRILLING, LLC

Well Drilled For: Oil Gas Seismic; # of Holes _____
 Enh Rec Storage Disposal Other _____
Well Class: Infield Pool Ext. Wildcat Other _____
Type Equipment: Mud Rotary Air Rotary Cable

Operator: _____
Well Name: _____
Original Completion Date: _____ Original Total Depth: _____

Directional, Deviated or Horizontal wellbore? Yes No
If Yes, true vertical depth: _____
Bottom Hole Location: _____
KCC DKT #: _____

Spot Description: NE/NW/NW/SE
ne - NW - NW - SW Sec. 9 Twp. 24 S. R. 16 E W
(a/a/a/a) 2,475 feet from N / S Line of Section
4,785 feet from E / W Line of Section

Is SECTION: Regular Irregular?

(Note: Locate well on the Section Plat on reverse side)

County: WOODSON
Lease Name: GLADES Well #: V-10
Field Name: VERNON

Is this a Prorated / Spaced Field? Yes No

Target Formation(s): SQUIRREL
Nearest Lease or unit boundary line (in footage): 495 feet MSL
Ground Surface Elevation: 1030 feet MSL

Water well within one-quarter mile: Yes No
Public water supply well within one mile: Yes No

Depth to bottom of fresh water: 150
Depth to bottom of usable water: 150

Surface Pipe by Alternate: I II
Length of Surface Pipe Planned to be set: 40'

Length of Conductor Pipe (if any): _____
Projected Total Depth: 1100'
Formation at Total Depth: SQUIRREL

Water Source for Drilling Operations:
 Well Farm Pond Other: _____

DWR Permit #: _____
(Note: Apply for Permit with DWR)

Will Cores be taken? Yes No
If Yes, proposed zone: SQUIRREL

AFFIDAVIT

The undersigned hereby affirms that the drilling, completion and eventual plugging of this well will comply with K.S.A. 55 et. seq.

It is agreed that the following minimum requirements will be met:

1. Notify the appropriate district office **prior** to spudding of well;
2. A copy of the approved notice of intent to drill **shall be** posted on each drilling rig;
3. The minimum amount of surface pipe as specified below **shall be set** by circulating cement to the top; in all cases surface pipe **shall be set** through all unconsolidated materials plus a minimum of 20 feet into the underlying formation.
4. If the well is dry hole, an agreement between the operator and the district office on plug length and placement is necessary **prior to plugging**;
5. The appropriate district office will be notified before well is either plugged or production casing is cemented in;
6. If an ALTERNATE II COMPLETION, production pipe shall be cemented from below any usable water to surface within **120 DAYS** of spud date. Or pursuant to Appendix "B" - Eastern Kansas surface casing order #133,891-C, which applies to the KCC District 3 area, alternate II cementing must be completed within 30 days of the spud date or the well shall be plugged. **In all cases, NOTIFY district office** prior to any cementing.

I hereby certify that the statements made herein are true and to the best of my knowledge and belief.

Date: JULY 29, 2010 Signature of Operator or Agent: _____ Title: PRESIDENT

For KCC Use ONLY
API # 15 - 207-27682-00-00
Conductor pipe required None feet
Minimum surface pipe required 40 feet per ALT. I II
Approved by: [Signature] 8-17-2010
This authorization expires: 8-17-2011
(This authorization void if drilling not started within 12 months of approval date.)
Spud date: _____ Agent: _____

Remember to:

- File Certification of Compliance with the Kansas Surface Owner Notification Act (KSONA-1) with Intent to Drill;
- File Drill Pit Application (form CDP-1) with Intent to Drill;
- File Completion Form ACO-1 within 120 days of spud date;
- File acreage attribution plat according to field proration orders;
- Notify appropriate district office 48 hours prior to workover or re-entry;
- Submit plugging report (CP-4) after plugging is completed (within 60 days);
- Obtain written approval before disposing or injecting salt water.
- If well will not be drilled or permit has expired (See: authorized expiration date) please check the box below and return to the address below.

Well will not be drilled or Permit Expired Date: _____
Signature of Operator or Agent: _____

Mail to: KCC - Conservation Division,
130 S. Market - Room 2078, Wichita, Kansas 67202

RECEIVED

AUG 16 2010

KCC WICHITA

9
24
16
 E
 W

For KCC Use ONLY
 API # 15 207-27682-0000

IN ALL CASES PLOT THE INTENDED WELL ON THE PLAT BELOW

In all cases, please fully complete this side of the form. Include items 1 through 5 at the bottom of this page.

Operator: VIVA INTERNATIONAL, INC
 Lease: GLADES
 Well Number: V-10
 Field: VERNON

Location of Well: County: WOODSON
 2,475 feet from N / S Line of Section
 4,785 feet from E / W Line of Section
 Sec. 9 Twp. 24 S. R. 16 E W

Number of Acres attributable to well: _____
 QTR/QTR/QTR/QTR of acreage: ~~NE~~ - NW - NW - ~~SE~~
NE SW

Is Section: Regular or Irregular

If Section is Irregular, locate well from nearest corner boundary.
 Section corner used: NE NW SE SW

PLAT

Show location of the well. Show footage to the nearest lease or unit boundary line. Show the predicted locations of lease roads, tank batteries, pipelines and electrical lines, as required by the Kansas Surface Owner Notice Act (House Bill 2032).
 You may attach a separate plat if desired.

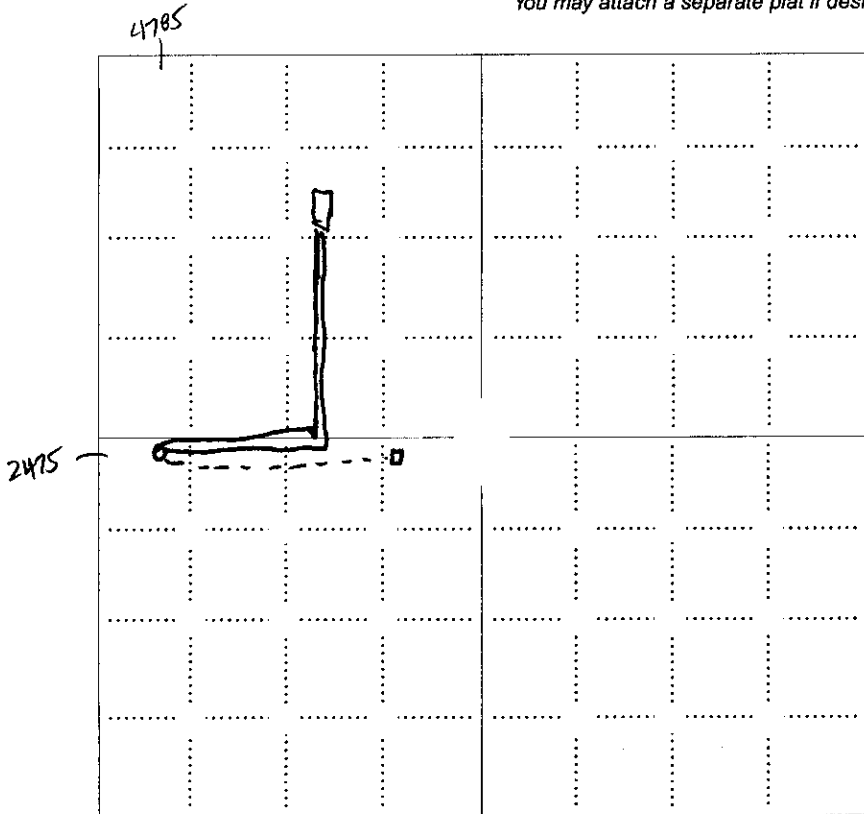

LEGEND

- Well Location
- Tank Battery Location
- Pipeline Location
- Electric Line Location
- Lease Road Location

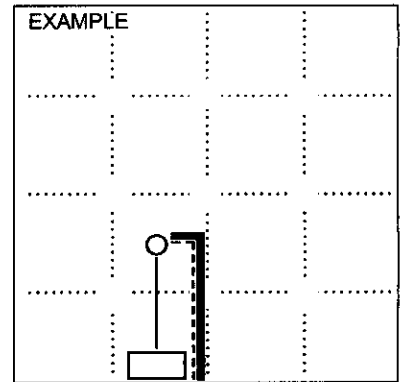

1980' FSL

NOTE: In all cases locate the spot of the proposed drilling location.

In plotting the proposed location of the well, you must show:

1. The manner in which you are using the depicted plat by identifying section lines, i.e. 1 section, 1 section with 8 surrounding sections, 4 sections, etc.
2. The distance of the proposed drilling location from the south / north and east / west outside section lines.
3. The distance to the nearest lease or unit boundary line (in footage).
4. If proposed location is located within a prorated or spaced field a certificate of acreage attribution plat must be attached: (CO-7 for oil wells; CG-8 for gas wells).
5. The predicted locations of lease roads, tank batteries, pipelines, and electrical lines.

KANSAS CORPORATION COMMISSION
OIL & GAS CONSERVATION DIVISION

RECEIVED
AUG 02 2010

Form CDP-1
May 2010
Form must be Typed

APPLICATION FOR SURFACE PIT KCC WICHITA

Submit in Duplicate

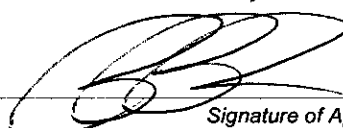
Operator Name: VIVA INTERNATIONAL, INC		License Number: 5556
Operator Address: 8357 MELROSE DRIVE		LENEXA KS 66214
Contact Person: ROBERT P BUKATY		Phone Number: 913-859-0438
Lease Name & Well No.: GLADES V-10		Pit Location (QQQQ): <u>NE - NW - NW - SW</u>
Type of Pit: <input type="checkbox"/> Emergency Pit <input type="checkbox"/> Burn Pit <input type="checkbox"/> Settling Pit <input checked="" type="checkbox"/> Drilling Pit <input type="checkbox"/> Workover Pit <input type="checkbox"/> Haul-Off Pit <small>(If WP Supply API No. or Year Drilled)</small>	Pit is: <input checked="" type="checkbox"/> Proposed <input type="checkbox"/> Existing If Existing, date constructed: _____ Pit capacity: _____ (bbls)	Sec. <u>9</u> Twp. <u>24</u> R. <u>16</u> <input checked="" type="checkbox"/> East <input type="checkbox"/> West <u>2,475</u> Feet from <input type="checkbox"/> North / <input checked="" type="checkbox"/> South Line of Section <u>4,785</u> Feet from <input checked="" type="checkbox"/> East / <input type="checkbox"/> West Line of Section WOODSON _____ County
Is the pit located in a Sensitive Ground Water Area? <input type="checkbox"/> Yes <input checked="" type="checkbox"/> No		Chloride concentration: _____ mg/l <small>(For Emergency Pits and Settling Pits only)</small>
Is the bottom below ground level? <input checked="" type="checkbox"/> Yes <input type="checkbox"/> No	Artificial Liner? <input type="checkbox"/> Yes <input checked="" type="checkbox"/> No	How is the pit lined if a plastic liner is not used? NATIVE CLAY
Pit dimensions (all but working pits): <u>40</u> Length (feet) <u>8</u> Width (feet) <input type="checkbox"/> N/A: Steel Pits Depth from ground level to deepest point: <u>5</u> (feet) <input type="checkbox"/> No Pit		
If the pit is lined give a brief description of the liner material, thickness and installation procedure.		Describe procedures for periodic maintenance and determining liner integrity, including any special monitoring.
Distance to nearest water well within one-mile of pit: <u>N/A</u> feet Depth of water well _____ feet		Depth to shallowest fresh water <u>150</u> feet. Source of information: <input type="checkbox"/> measured <input type="checkbox"/> well owner <input type="checkbox"/> electric log <input checked="" type="checkbox"/> KDWR
Emergency, Settling and Burn Pits ONLY: Producing Formation: _____ Number of producing wells on lease: _____ Barrels of fluid produced daily: _____ Does the slope from the tank battery allow all spilled fluids to flow into the pit? <input type="checkbox"/> Yes <input type="checkbox"/> No		Drilling, Workover and Haul-Off Pits ONLY: Type of material utilized in drilling/workover: <u>FRESH MUD</u> Number of working pits to be utilized: <u>1</u> Abandonment procedure: <u>ALLOW FLUID TO EVAPORATE, BACKFILL AND RETURN TO NORMAL USE</u> Drill pits must be closed within 365 days of spud date.
I hereby certify that the above statements are true and correct to the best of my knowledge and belief.		
JULY 29, 2010 Date		 Signature of Applicant or Agent

RECEIVED
AUG 16 2010
KCC WICHITA

15-207-27682-0000

KCC OFFICE USE ONLY

Liner Steel Pit RFAC RFAS
Date Received: 8-16-10 Permit Number: _____ Permit Date: 8-17-10 Lease Inspection: Yes No

Mail to: KCC - Conservation Division, 130 S. Market - Room 2078, Wichita, Kansas 67202

APPLICATION FOR SURFACE PIT (FORM CDP-1) Instructions

General Instructions.

1. All Notices of Intent to Drill must include an Application for Surface Pit, even if steel pits will be used.
2. Operators need to submit two copies of all CDP-1s.
3. Form must be typed.

Section 1: Operator Information.

- 1a. **Operator Name.** Enter the operator's full name as it appears on operator's license.
- 1b. **License Number.** Enter the operator's license number. To verify KCC operator license information check the Commission's website at http://kcc.ks.gov/conservation/oil_license.cgi or contact the Conservation Division's Licensing Department at (316) 337-6194.
- 1c. **Operator Address.** Enter the operator's mailing address.
- 1d. **Contact Person.** Enter the name of the individual who will be the operator's contact person for this Application for Surface Pit, should Conservation Division Staff need to contact the operator about the Application for Surface Pit. The contact person may be the operator or the operator's agent.
- 1e. **Phone Number.** Enter the phone number of the contact person, so that Conservation Division Staff may easily reach the contact person if necessary.

Section 2: Lease/Well/Pit Information.

- 2a. **Lease Name & Well No.** Enter the name of the lease, and if applicable the well number, at which the pit is or will be located.
- 2b. **Type of Pit.** Mark the appropriate box to indicate the type of pit. Note—if the pit is a workover pit, the operator must enter the API No. or Year Drilled of the well which is to be worked over.
- 2c. **Proposed or Existing Pit.** Operator should mark the appropriate box to indicate if the pit is proposed or already exists.
 - 2c(1). **Existing Pits.** The operator should provide the date pit was constructed.
 - 2c(2). **Proposed and Existing Pits.** The operator must provide the pit capacity.
- 2d. **Pit Location.**
 - 2d(1). **¼ ¼ ¼ ¼ Section.** The operator should list the location of the pit by ¼ ¼ ¼ ¼ Section.
 - 2d(2). **Sec., Twp., and R.** The operator should enter the Section, Township and Range Number in which the pit is located, and should mark either the "East" or "West" box to indicate if the Range # is East or West.
 - 2d(3). **Footage Location.** This is where the operator reports the location of the pit from the North or South section line and the East or West section line. Enter in the blank provide the number of feet the pit is or will be from the North or South section line and then mark the appropriate box for the measurement to indicate if the footage is from the North or South section line. Follow the same procedure with respect to the location of the pit from the East or West section line.
 - 2d(4). **County.** Enter the county in which the pit is or will be located.
- 2e. **Sensitive Groundwater Area.** Mark the appropriate box as to whether or not the pit is located in a Sensitive Groundwater Area. Operators may find a listing of Sensitive Groundwater Areas in Table III of the Conservation Division's Rules and Regulations. The Commission's rules and regulations for the conservation of oil and gas, including Table III, are available in an Adobe pdf file from the Conservation Division's website at <http://kcc.ks.gov/conservation/index.htm>.
- 2f. **Chloride Concentration (for emergency and settling pits only).** Indicate the chloride concentration level of fluids which the pit is or will be used to contain. A sample should be taken from the salt water tank. This information is needed to determine the potential for contamination should the salt water tank discharge into the emergency pit.

- 2g. **Below Ground Level.** Mark the appropriate box to indicate whether the bottom of the pit is below ground level.
- 2h. **Artificial Liner.** Mark the appropriate box to indicate whether the pit is or will be constructed with an artificial liner.
- 2i. **Other Liner.** Explain how the pit is constructed if a plastic liner is not used.
- 2j. **Pit Dimensions (all but working pits).** For all but steel pits, enter the length, width, and depth (from ground level to the deepest point) in feet of the pit. If the pit is a steel pit, the operator only needs to mark the "steel pits" box. If no pits will be used, mark the "No Pit" box.

Section 3: Description of Liner.

If the pit is lined, enter a brief description of the liner material, thickness, and installation procedure.

Section 4: Description of Maintenance.

Enter a brief description of the procedures used for periodic maintenance and determining liner integrity, including any special monitoring.

Section 5: Distance to Nearest Water Well Within One Mile of Pit.

Enter the distance to the nearest water well within one mile of the pit location and the total depth of the water well. If there are not any water wells within a one-mile radius of the pit location, the space should be left blank. Water well information is available from the Kansas Geological Survey's website, at <http://www.kgs.ku.edu/Magellan/WaterWell/index.html>.

Section 6: Shallowest Freshwater Depth.

Enter the depth to the shallowest fresh water in the area of the pit and mark the appropriate box as the source of the freshwater information.

Section 7: Emergency, Settling, and Burn Pits ONLY.

Enter the formation from which wells on the lease are producing, the number of producing wells on the lease, and the number of barrels of fluids produced daily on the lease. The operator should also mark the appropriate box to indicate if the slope of the tank battery allows all spilled fluids to flow in the pit.

Section 8: Drilling, Workover, and Haul-Off Pits ONLY.

Enter the type of material utilized in the drilling or workover of the well, the number of working pits to be utilized, and the procedure to be used for abandoning the pits after work at the well is complete.

Section 9: Affidavit.

Date and sign the certification that the above statements are true and correct to the best of the signee's knowledge and belief.

August 17, 2010

Viva International, Inc.
8357 Melrose Drive
Lenexa, KS 66214

RE: Drilling Pit Application
Glades Lease Well No. V-10
SW/4 Sec. 09-24S-16E
Woodson County, Kansas

Dear Sir or Madam:

District staff has inspected the above referenced location and has determined that the reserve pit shall be constructed **without slots**, the bottom shall be flat and reasonably level, and the free fluids must be removed. The fluids are to be removed from the reserve pit as soon as practical after drilling operations have ceased.

If production casing is set all completion fluids shall be removed from the working pits daily. NO completion fluids or non-exempt wastes shall be placed in the reserve pit.

The fluids should be taken to an authorized disposal well. Please call the District Office at (620) 432-2300 when the fluids have been removed. Please file form CDP-5 (August 2004), Exploration and Production Waste Transfer, within 30 days of fluid removal. Conservation division forms are available through our office and on the KCC web site:
www.kcc.state.ks.us/conservation/forms.

A copy of this letter should be posted in the doghouse along with the approved Intent to Drill.

If you have any questions or concerns please feel free to contact the undersigned at the above address.

Sincerely,

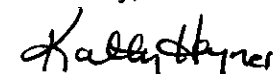
Kathy Haynes

Environmental Protection and Remediation Department

cc: File

**CERTIFICATION OF COMPLIANCE WITH THE WICHITA
KANSAS SURFACE OWNER NOTIFICATION ACT**

This form must be submitted with all Forms C-1 (Notice of Intent to Drill); CB-1 (Cathodic Protection Borehole Intent); T-1 (Request for Change of Operator Transfer of Injection or Surface Pit Permit); and CP-1 (Well Plugging Application). Any such form submitted without an accompanying Form KSONA-1 will be returned.

Select the corresponding form being filed: C-1 (Intent) CB-1 (Cathodic Protection Borehole Intent) T-1 (Transfer) CP-1 (Plugging Application)

OPERATOR: License # 5556
Name: VIVA INTERNATIONAL, INC
Address 1: 8357 MELROSE DRIVE
Address 2: _____
City: LENEXA State: KS Zip: 66214 + _____
Contact Person: ROBERT P BUKATY
Phone: (913) 859-0438 Fax: (913) 859-0247
Email Address: ROBERT.BUKATY@VIVAINTERNATIONAL.US

Well Location:
NE NW SW Sec. 9 Twp. 24 S. R. 16 East West
County: WOODSON
Lease Name: GLADES Well #: V-10

If filing a Form T-1 for multiple wells on a lease, enter the legal description of the lease below:

8-16-2010
~~KSONA FEE PAID~~ KSONA FEE PAID
8-2-2010

Surface Owner Information:

Name: _____
Address 1: _____
Address 2: _____
City: _____ State: _____ Zip: _____ + _____

When filing a Form T-1 involving multiple surface owners, attach an additional sheet listing all of the information to the left for each surface owner. Surface owner information can be found in the records of the register of deeds for the county, and in the real estate property tax records of the county treasurer.

If this form is being submitted with a Form C-1 (Intent) or CB-1 (Cathodic Protection Borehole Intent), you must supply the surface owners and the KCC with a plat showing the predicted locations of lease roads, tank batteries, pipelines, and electrical lines. The locations shown on the plat are preliminary non-binding estimates. The locations may be entered on the Form C-1 plat, Form CB-1 plat, or a separate plat may be submitted.

Select one of the following:

- I certify that, pursuant to the Kansas Surface Owner Notice Act (House Bill 2032), I have provided the following to the surface owner(s) of the land upon which the subject well is or will be located: 1) a copy of the Form C-1, Form CB-1, Form T-1, or Form CP-1 that I am filing in connection with this form; 2) if the form being filed is a Form C-1 or Form CB-1, the plat(s) required by this form; and 3) my operator name, address, phone number, fax, and email address.
- I have not provided this information to the surface owner(s). I acknowledge that, because I have not provided this information, the KCC will be required to send this information to the surface owner(s). To mitigate the additional cost of the KCC performing this task, I acknowledge that I am being charged a \$30.00 handling fee, payable to the KCC, which is enclosed with this form.

If choosing the second option, submit payment of the \$30.00 handling fee with this form. If the fee is not received with this form, the KSONA-1 form and the associated Form C-1, Form CB-1, Form T-1, or Form CP-1 will be returned.

I hereby certify that the statements made herein are true and correct to the best of my knowledge and belief.

Date: JULY 29, 2010 Signature of Operator or Agent: _____

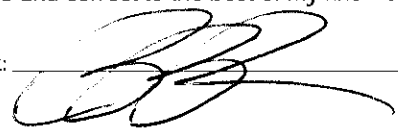

Title: PRESIDENT

RECEIVED
AUG 16 2010

KCC WICHITA

15-207-27682-0000

KSONA-1 SUPPLEMENTAL SURFACE OWNER INFORMATION

GLADES LEASE SECTION 9, TOWNSHIP 24 SOUTH, RANGE 16 EAST
WOODSON COUNTY, KANSAS

OWNER 1

Mr. Cline Karmann
1562 130th Rd
Yates Center, KS 66783-5208

OWNER 2

Mr Keith Karmann
1501 Osage Rd
Yates Center, KS 66783-4463

RECEIVED

AUG 13 2010

KCC WICHITA

August 16, 2010

Mr. Cline Karmann
1562 130th Rd
Yates Center, KS 66783-5208

RE: Kansas Surface Owners Notice Act

Dear Mr. Karmann:

The 2009 Legislature passed House Bill 2032, known as the Kansas Surface Owners Notice Act. This Act requires the KCC to provide copies of drilling intents, operator transfers, and well plugging applications to the surface owner, if they are not provided by the lease operator. The operator has advised us they have not provided you with a copy of the attached form. Therefore, this letter and the attached form shall serve as notice of the operator's action. You do not need to respond to the KCC. Please contact the operator listed on the form if you have any questions.

Very truly yours,

A handwritten signature in black ink, appearing to read "Rick Hestermann", with a long horizontal flourish extending to the right.

Rick Hestermann
Production Department

August 16, 2010

Mr. Keith Karmann
1501 Osage Rd
Yates Center, KS 66783-4463

RE: Kansas Surface Owners Notice Act

Dear Mr. Karmann:

The 2009 Legislature passed House Bill 2032, known as the Kansas Surface Owners Notice Act. This Act requires the KCC to provide copies of drilling intents, operator transfers, and well plugging applications to the surface owner, if they are not provided by the lease operator. The operator has advised us they have not provided you with a copy of the attached form. Therefore, this letter and the attached form shall serve as notice of the operator's action. You do not need to respond to the KCC. Please contact the operator listed on the form if you have any questions.

Very truly yours,

A handwritten signature in black ink, appearing to read "Rick Hestermann", with a long horizontal flourish extending to the right.

Rick Hestermann
Production Department