

For KCC Use: **7-27-2011**
 Effective Date: **7-27-2011**
 District # _____
 SGA? Yes No

KANSAS CORPORATION COMMISSION
 OIL & GAS CONSERVATION DIVISION

Form C-1
 March 2010
 Form must be Typed
 Form must be Signed
 All blanks must be Filled

NOTICE OF INTENT TO DRILL

Must be approved by KCC five (5) days prior to commencing well
Form KSONA-1, Certification of Compliance with the Kansas Surface Owner Notification Act, MUST be submitted with this form.

Expected Spud Date: July 26 2011
 month day year

Spot Description: **1080-FEL-2010-FST**
 N/2 - NW - SE - Sec. 2 Twp. 24 S. R. 15 E W
 2,310 feet from N / S Line of Section
 1,980 feet from E / W Line of Section

OPERATOR: License# **5474** ✓
 Name: **Northern Lights Oil Co., L.C.**
 Address 1: **P.O. Box 164**
 Address 2: _____
 City: **Andover** State: **KS** Zip: **67002** +
 Contact Person: **Robert Sutherland**
 Phone: **316-305-0493**

Is SECTION: Regular Irregular?
 (Note: Locate well on the Section Plat on reverse side)
 County: **Stafford**
 Lease Name: **Munz** Well #: **2**
 Field Name: **Macksville**

CONTRACTOR: License# **4958** ✓
 Name: **Mallard JV, Inc.**

Is this a Prorated / Spaced Field? Yes No
 Target Formation(s): **Viola Chert**

Well Drilled For: Oil Gas Enh Rec Storage Disposal Seismic Other: _____ # of Holes _____
 Well Class: Onfield Pool Ext. Wildcat Other _____
 Type Equipment: Mud Rotary Air Rotary Cable
 If OWWO: old well information as follows: _____

Nearest Lease or unit boundary line (in footage): **330'**
 Ground Surface Elevation: **2006'** feet MSL
 Water well within one-quarter mile: Yes No
 Public water supply well within one mile: Yes No
 Depth to bottom of fresh water: **100'**
 Depth to bottom of usable water: **180' 190'**
 Surface Pipe by Alternate: I II
 Length of Surface Pipe Planned to be set: **300'**
 Length of Conductor Pipe (if any): _____
 Projected Total Depth: **4230'**
 Formation at Total Depth: **Arbuckle**

Operator: _____
 Well Name: _____
 Original Completion Date: _____ Original Total Depth: _____

Water Source for Drilling Operations:
 Well Farm Pond Other: _____
 DWR Permit #: _____ (Note: Apply for Permit with DWR)

Directional, Deviated or Horizontal wellbore? Yes No
 If Yes, true vertical depth: _____
 Bottom Hole Location: _____
 KCC DKT #: _____

Will Cores be taken? Yes No
 If Yes, proposed zone: _____

AFFIDAVIT

The undersigned hereby affirms that the drilling, completion and eventual plugging of this well will comply with K.S.A. 55 et. seq.
 It is agreed that the following minimum requirements will be met:

1. Notify the appropriate district office **prior** to spudding of well;
2. A copy of the approved notice of intent to drill **shall be** posted on each drilling rig;
3. The minimum amount of surface pipe as specified below **shall be set** by circulating cement to the top; in all cases surface pipe **shall be set** through all unconsolidated materials plus a minimum of 20 feet into the underlying formation.
4. If the well is dry hole, an agreement between the operator and the district office on plug length and placement is necessary **prior to plugging**;
5. The appropriate district office will be notified before well is either plugged or production casing is cemented in;
6. If an ALTERNATE II COMPLETION, production pipe shall be cemented from below any usable water to surface within **120 DAYS** of spud date.
 Or pursuant to Appendix "B" - Eastern Kansas surface casing order #133,891-C, which applies to the KCC District 3 area, alternate II cementing must be completed within 30 days of the spud date or the well shall be plugged. **In all cases, NOTIFY district office** prior to any cementing.

I hereby certify that the statements made herein are true and to the best of my knowledge and belief.

Date: **7-18-11** Signature of Operator or Agent:  Title: **Exploration Manager**

For KCC Use ONLY
 API # 15 - **185-23692-0000**
 Conductor pipe required **None** feet
 Minimum surface pipe required **210** feet per ALT. I II
 Approved by: **July 7-22-2011**
 This authorization expires: **7-22-2012**
 (This authorization void if drilling not started within 12 months of approval date.)
 Spud date: _____ Agent: _____

Remember to:

- File Certification of Compliance with the Kansas Surface Owner Notification Act (KSONA-1) with Intent to Drill; **2**
- File Drill Pit Application (form CDP-1) with Intent to Drill; **24**
- File Completion Form ACO-1 within 120 days of spud date; **15**
- File acreage attribution plat according to field proration orders;
- Notify appropriate district office 48 hours prior to workover or re-entry;
- Submit plugging report (CP-4) after plugging is completed (within 60 days);
- Obtain written approval before disposing or injecting salt water.
- If well will not be drilled or permit has expired (See: authorized expiration date) please check the box below and return to the address below.

Well will not be drilled or Permit Expired Date: _____
 Signature of Operator or Agent: _____

RECEIVED
 JUL 19 2011

Mail to: KCC - Conservation Division,
 130 S. Market - Room 2078, Wichita, Kansas 67202

KCC WICHITA

For KCC Use ONLY

API # 15 - 185-23692-0000

IN ALL CASES PLOT THE INTENDED WELL ON THE PLAT BELOW

In all cases, please fully complete this side of the form. Include items 1 through 5 at the bottom of this page.

Operator: Northern Lights Oil Co., L.C.
Lease: Munz
Well Number: 2
Field: Macksville

Location of Well: County: Stafford
2,310 feet from N / S Line of Section
1,980 feet from E / W Line of Section
Sec. 2 Twp. 24 S. R. 15 E W

Number of Acres attributable to well:
QTR/QTR/QTR/QTR of acreage: N/2 - NW - SE

Is Section: Regular or Irregular

If Section is Irregular, locate well from nearest corner boundary.

Section corner used: NE NW SE SW

PLAT

Show location of the well. Show footage to the nearest lease or unit boundary line. Show the predicted locations of lease roads, tank batteries, pipelines and electrical lines, as required by the Kansas Surface Owner Notice Act (House Bill 2032). You may attach a separate plat if desired.

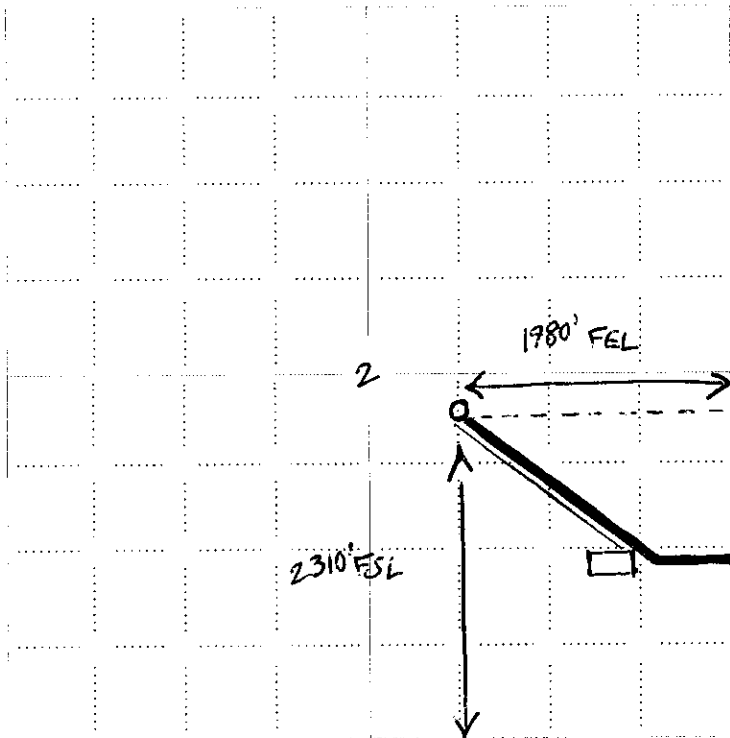

LEGEND

- Well Location
- Tank Battery Location
- Pipeline Location
- Electric Line Location
- Lease Road Location

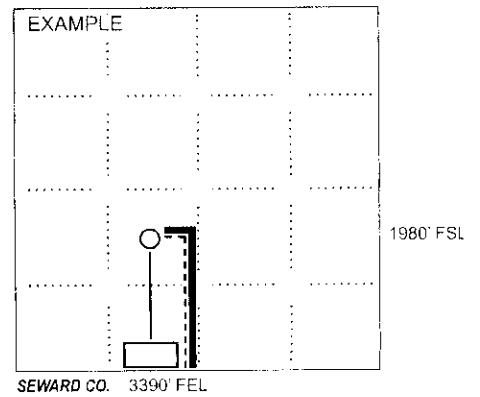

NOTE: In all cases locate the spot of the proposed drilling location.

In plotting the proposed location of the well, you must show:

1. The manner in which you are using the depicted plat by identifying section lines, i.e. 1 section, 1 section with 8 surrounding sections, 4 sections, etc.
2. The distance of the proposed drilling location from the south / north and east / west outside section lines.
3. The distance to the nearest lease or unit boundary line (in footage).
4. If proposed location is located within a prorated or spaced field a certificate of acreage attribution plat must be attached: (CO-7 for oil wells, CG-8 for gas wells).
5. The predicted locations of lease roads, tank batteries, pipelines, and electrical lines.

RECEIVED
JUL 19 2011

KCC WICHITA

15-185-23692-0000

KANSAS CORPORATION COMMISSION
OIL & GAS CONSERVATION DIVISION

Form KSONA-1
July 2010

Form Must Be Typed
Form must be Signed
All blanks must be Filled

**CERTIFICATION OF COMPLIANCE WITH THE
KANSAS SURFACE OWNER NOTIFICATION ACT**

This form must be submitted with all Forms C-1 (Notice of Intent to Drill); CB-1 (Cathodic Protection Borehole Intent); T-1 (Request for Change of Operator Transfer of Injection or Surface Pit Permit); and CP-1 (Well Plugging Application). Any such form submitted without an accompanying Form KSONA-1 will be returned.

Select the corresponding form being filed: C-1 (Intent) CB-1 (Cathodic Protection Borehole Intent) T-1 (Transfer) CP-1 (Plugging Application)

OPERATOR: License # 5474
Name: Northern Lights Oil Co., L.C.
Address 1: P.O. Box 164
Address 2:
City: Andover State: KS Zip: 67002
Contact Person: Robert Sutherland
Phone: (316) 305-0493 Fax: ()
Email Address: northernoil@sbcglobal.net

Well Location:
N/2 NW SE Sec. 2 Twp. 24 S. R. 15 East West
County: Stafford
Lease Name: Munz Well #: 2

If filing a Form T-1 for multiple wells on a lease, enter the legal description of the lease below:

Surface Owner Information:

Name: Juan Munz
Address 1: 435 W. 3rd Ave.
Address 2:
City: Saint John State: KS Zip: 67576

When filing a Form T-1 involving multiple surface owners, attach an additional sheet listing all of the information to the left for each surface owner. Surface owner information can be found in the records of the register of deeds for the county, and in the real estate property tax records of the county treasurer.

If this form is being submitted with a Form C-1 (Intent) or CB-1 (Cathodic Protection Borehole Intent), you must supply the surface owners and the KCC with a plat showing the predicted locations of lease roads, tank batteries, pipelines, and electrical lines. The locations shown on the plat are preliminary non-binding estimates. The locations may be entered on the Form C-1 plat, Form CB-1 plat, or a separate plat may be submitted.

Select one of the following:

- I certify that, pursuant to the Kansas Surface Owner Notice Act (House Bill 2032), I have provided the following to the surface owner(s) of the land upon which the subject well is or will be located: 1) a copy of the Form C-1, Form CB-1, Form T-1, or Form CP-1 that I am filing in connection with this form; 2) if the form being filed is a Form C-1 or Form CB-1, the plat(s) required by this form; and 3) my operator name, address, phone number, fax, and email address.
- I have not provided this information to the surface owner(s). I acknowledge that, because I have not provided this information, the KCC will be required to send this information to the surface owner(s). To mitigate the additional cost of the KCC performing this task, I acknowledge that I am being charged a \$30.00 handling fee, payable to the KCC, which is enclosed with this form.

If choosing the second option, submit payment of the \$30.00 handling fee with this form. If the fee is not received with this form, the KSONA-1 form and the associated Form C-1, Form CB-1, Form T-1, or Form CP-1 will be returned.

I hereby certify that the statements made herein are true and correct to the best of my knowledge and belief.

Date: 7-18-11 Signature of Operator or Agent:  Title: Exploration Manager

RECEIVED
JUL 19 2011

15-185-23692-0000

Sheet1

Munz #2 Surface Owner Information

Jerold Dan Munz
2833 Blush Dr.
Lakeland, FL 33813

Juan David Munz
435 W. Third
St. John, KS 67576

Julie Marie Theel
1135 N. Walker Lane
Olathe, KS 66061

Jodine Mae Trout
2556 Ousdahl Rd.
Lawrence, KS 66046

Jeffery Dale Munz
2527 21st St.
Great Bend, KS 67530

RECEIVED
JUL 19 2011
KCC WICHITA

KANSAS CORPORATION COMMISSION
OIL & GAS CONSERVATION DIVISION

Form CDP-1
May 2010
Form must be Typed

APPLICATION FOR SURFACE PIT

Submit in Duplicate

Operator Name: Northern Lights Oil Co., L.C.		License Number: 5474	
Operator Address: P.O. Box 164		Andover KS 67002	
Contact Person: Robert Sutherland		Phone Number: 316-305-0493	
Lease Name & Well No.: Munz 2		Pit Location (QQQQ): N/2 NW SE	
Type of Pit: <input type="checkbox"/> Emergency Pit <input type="checkbox"/> Settling Pit <input type="checkbox"/> Workover Pit <small>(If WP Supply API No. or Year Drilled)</small>	Pit is: <input checked="" type="checkbox"/> Proposed <input type="checkbox"/> Existing If Existing, date constructed: Pit capacity: 2,800 (bbls)	Sec. 2 Twp. 24 R. 15 East <input checked="" type="checkbox"/> West 2,310 Feet from North / <input checked="" type="checkbox"/> South Line of Section 1,980 Feet from <input checked="" type="checkbox"/> East / <input type="checkbox"/> West Line of Section Stafford County	
Is the pit located in a Sensitive Ground Water Area? <input checked="" type="checkbox"/> Yes <input type="checkbox"/> No		Chloride concentration: _____ mg/l <small>(For Emergency Pits and Settling Pits only)</small>	
Is the bottom below ground level? <input checked="" type="checkbox"/> Yes <input type="checkbox"/> No		Artificial Liner? <input type="checkbox"/> Yes <input checked="" type="checkbox"/> No	
How is the pit lined if a plastic liner is not used? Drilling mud and shale from well bore			
Pit dimensions (all but working pits): 80 Length (feet) 80 Width (feet) N/A: Steel Pits		Depth from ground level to deepest point: 3 (feet) No Pit	
If the pit is lined give a brief description of the liner material, thickness and installation procedure.		Describe procedures for periodic maintenance and determining liner integrity, including any special monitoring.	
Distance to nearest water well within one-mile of pit: 738 feet Depth of water well 96 feet		Depth to shallowest fresh water 19 feet. Source of information: <input type="checkbox"/> measured <input type="checkbox"/> well owner <input type="checkbox"/> electric log <input checked="" type="checkbox"/> KDWR	
Emergency, Settling and Burn Pits ONLY: Producing Formation: _____ Number of producing wells on lease: _____ Barrels of fluid produced daily: _____ Does the slope from the tank battery allow all spilled fluids to flow into the pit? <input type="checkbox"/> Yes <input type="checkbox"/> No		Drilling, Workover and Haul-Off Pits ONLY: Type of material utilized in drilling/workover: Fresh water and drilling mud Number of working pits to be utilized: 2 Abandonment procedure: Evaporate and Backfill Drill pits must be closed within 365 days of spud date.	
I hereby certify that the above statements are true and correct to the best of my knowledge and belief.			
7-18-11 Date		 Signature of Applicant or Agent	

15-185-23692-00-00

KCC OFFICE USE ONLY			
		<input type="checkbox"/> Liner <input type="checkbox"/> Steel Pit <input checked="" type="checkbox"/> RFAC <input checked="" type="checkbox"/> RFAS	
Date Received: 7-19-11	Permit Number: _____	Permit Date: 7-22-11	Lease Inspection: <input checked="" type="checkbox"/> RECEIVED

Mail to: KCC - Conservation Division, 130 S. Market - Room 2078, Wichita, Kansas 67202

JUL 19 2011

KCC WICHITA

July 22, 2011

Northern Lights Oil Co., LC
PO Box 164
Andover, KS 67002

RE: Drilling Pit Application
Munz Lease Well No. 2
SE/4 Sec. 02-24S-15W
Stafford County, Kansas

Dear Sir or Madam:

District staff has inspected the above referenced location and has determined that the reserve pit shall be constructed **without slots**, the bottom shall be flat and reasonably level and the free fluids must be removed. The fluids are to be removed from the reserve pit as soon as the Hutchinson Salt section has been drilled through and displacement of the fluids into the reserve pit has occurred. The fluids should be removed again after drilling operations have ceased. **If production casing is set all completion fluids shall be removed from the working pits daily. NO completion fluids or non-exempt wastes shall be placed in the reserve pit.**

The fluids should be taken to an authorized disposal well. Please call the District Office at (620) 225-8888 when the fluids have been removed. Please file form CDP-5 (August 2004), Exploration and Production Waste Transfer, within 30 days of fluid removal. Conservation division forms are available through our office and on the KCC web site: www.kcc.state.ks.us/conservation/forms.

A copy of this letter should be posted in the doghouse along with the approved Intent to Drill.

If you have any questions or concerns please feel free to contact the undersigned at the above address.

Sincerely,

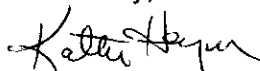

Kathy Haynes
Department of Environmental Protection and Remediation

cc: File