

STATE OF KANSAS
STATE CORPORATION COMMISSION
CONSERVATION DIVISION
130 South Market - Room 2078
Wichita, Kansas 67202

FORM CP-1 (3/92)

WELL PLUGGING APPLICATION FORM
(PLEASE TYPE FORM and File ONE Copy)

API # 15-129-20213-0000 (Identifier number of this well). This must be listed for wells drilled since 1967; if no API# was issued, indicate spud or completion date.

WELL OPERATOR ANADARKO PETROLEUM CORPORATION KCC LICENSE # 4549
(owner/company name) (operator's)

ADDRESS P.O. BOX 351 CITY LIBERAL

STATE KANSAS ZIP CODE 67905-0351 CONTACT PHONE (316) 624-6253

LEASE INTERSTATE UNIT WELL# 79 SEC. 21 T. 34S R. 43W (xxxx/West)

50' FROM W LINE - SW/4 SPOT LOCATION/QQQQ COUNTY MORTON

1320' FEET (in exact footage) FROM S/X (circle one) LINE OF SECTION (NOT Lease Line)

50' FEET (in exact footage) FROM X/W (circle one) LINE OF SECTION (NOT Lease Line)

Check One: OIL WELL GAS WELL D&A SWD/ENHR WELL DOCKET# E-21,363

CONDUCTOR CASING SIZE 20" SET AT 75' CEMENTED WITH 200 SACKS

SURFACE CASING SIZE 8-5/8" SET AT 1142' CEMENTED WITH 600 SACKS

PRODUCTION CASING SIZE 5-1/2" SET AT 4205' CEMENTED WITH 100 SACKS

LIST (ALL) PERFORATIONS and BRIDGEPLUG SET: 4111-4117, 4123-4129, 4135-4130

ELEVATION 3486.6/ T.D. 4210 PBDT 4145 ANHYDRITE DEPTH
(G.L./K.B.) (Stone Corral Formation)

CONDITION OF WELL: GOOD POOR CASING LEAK JUNK IN HOLE

PROPOSED METHOD OF PLUGGING SEE ATTACHED PLUG AND ABANDON PROCEDURE

(If additional space is needed attach separate page)

IS WELL LOG ATTACHED TO THIS APPLICATION AS REQUIRED? NO IS ACO-1 FILED? YES

If not explain why? LOGS SUBMITTED W/ ORIG. COMPLETION REPORT OR DRILLER'S LOG.

PLUGGING OF THIS WELL WILL BE DONE IN ACCORDANCE WITH K.S.A. 55-101 et. seq. AND THE RULES AND REGULATIONS OF THE STATE CORPORATION COMMISSION.

LIST NAME OF COMPANY REPRESENTATIVE AUTHORIZED TO BE IN CHARGE OF PLUGGING OPERATIONS:

MR. DAVE GILMORE PHONE# (316) 544-7240

ADDRESS P.O. BOX 208 City/State HUGOTON, KANSAS 67951

PLUGGING CONTRACTOR SARGENT & HORTON PLUGGING, INC. KCC LICENSE # 31151
(company name) (contractor's)

ADDRESS RT 1, BOX 49BA, TYRONE, OK 73951-9731 PHONE # (405) 854-6515

PROPOSED DATE AND HOUR OF PLUGGING (If Known?) UPON APPROVAL

PAYMENT OF THE PLUGGING FEE (K.A.R. 82-3-118) WILL BE GUARANTEED BY OPERATOR OR AGENT

DATE: 11/3/98 AUTHORIZED OPERATOR/AGENT: Shawn D. Young

SHAWN D. YOUNG (Signature)
DIVISION PRODUCTION ENGINEER

11-12-98

Plug & Abandon Procedure

ISU #79
Sec 21-34S-43W
1320' FSL & 50' FWL
Interstate Unit
Morton County, Kansas

Charge to: 501301
WI: 93.87% RI: 86.10%
TD: 4210'
PBTD: 4145'
GL Elev: 3468'
Perfs: 4111'- 4140'

Tubulars:
Surface Csg: 8-5/8", 23#, @ 1142'
Prod Csg: 5-1/2", 15.5#, @ 4205'
Tubing: 2-7/8", @ 3581'

Status: Shut in w/ CSG Leak.

Objective: P&A

1. *Notify KCC District office and BLM office five days before plugging.*
2. MIRU PU. TIH w/ overshot and TBG. Latch onto 2-7/8" TBG @ 293'.
3. RIH w/ snd line through TBG and fish TBG plug @ 3581'.
4. MIRU CTU. RIH w/ 1.25" CT to 3581'. Mix and pump 5 SKS hulls + 100 SKS CMT. Displace cement to 4000' w/9 ppg mud.
5. ROH w/ CT. RDMO CTU.
6. Pull freepoint on TBG. Shoot off TBG @ freepoint. Spot 50 SKS CMT at cut-off point. RDMO PU.
7. MIRU CSG Pullers. Pull freepoint on CSG. Shoot off CSG @ freepoint. Spot 50 SKS CMT at cut-off point.
8. Pull CSG to 1240'. Spot 50 SKS CMT from 1242'- 1042'.
9. Pull CSG to 600'. Spot 50 SKS CMT from 650'- 550'.
10. Pull CSG to 40'. Spot 20 SKS CMT from 40'- 4'.
11. Cutoff 8-5/8" CSG and 5-1/2" CSG 4' below GL and weld on cap.
12. RDMO Pluggers. Restore location to original condition.

Dustin M. Faulkner
October 14, 1998

Approvals: MBJ _____

SDY _____

ISU #79
Plug & Abandon
Page No. 1

90-10-21-101091
1998 OCT 17 12 09 PM '98
MORTON COUNTY, KANSAS
SAS OFFICE

14-Oct-98

WELL NAME: ISU #79
LEGAL: 1320 FSL & 50 FWL
SS-TWN-RNG: 21-34S-43W
FIELD: INTERSTATE UNIT
COUNTY, STATE: MORTON COUNTY, KANSAS
WI: 93.87%
RI: 86.10%
SURFACE CASING: 8-5/8", 23#, @ 1142'
PROD CASING: 5-1/2", 15.5#, @ 4205'
TUBING: 2-7/8" 8RD @ 3581
GL: 3468
TD: 4210
PBTD: 4145

WELLBORE SKETCH

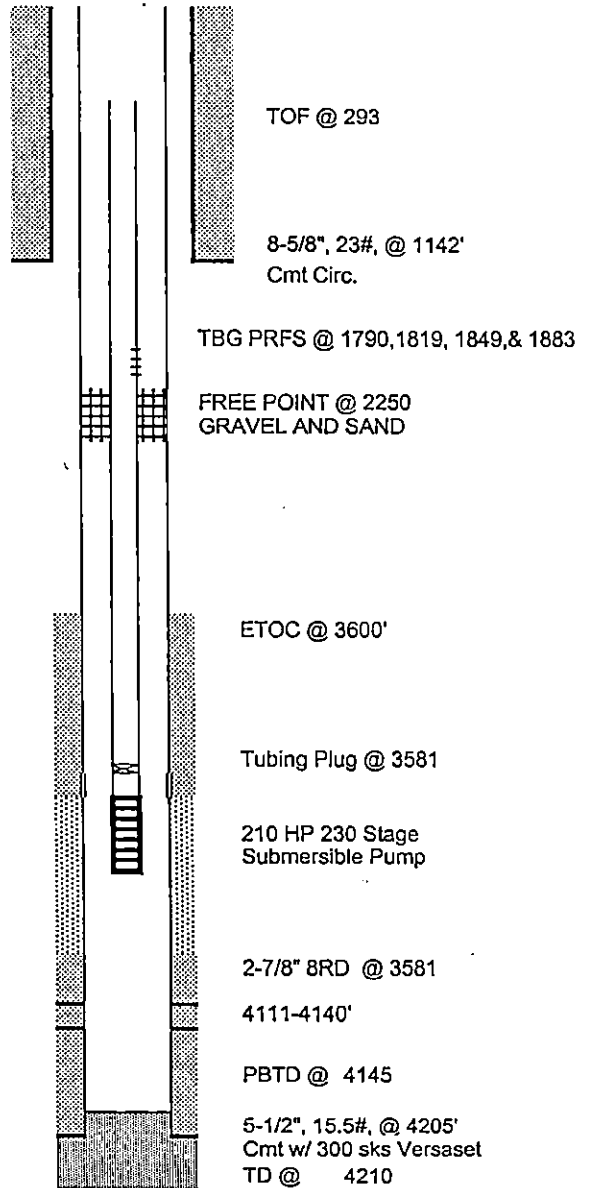

PERFORATED INTERVALS

FORMATION	INTERVAL	SHOT DENSITY
PURDY SAND	4111-17	2
	4123-29	2
	4135-40	2

STIMULATION HISTORY

DATE	ACTION	RESULT
Aug-75	F/ 15000 GAL GELL CRUDE, 15000# 10-20 SND	500 BOPD 1000 BWPD
Feb-84	AV 2000 GAL 7.5% HCl	

PUMPING EQUIPMENT

--

DATE BHP

SUBSURFACE EQUIPMENT

210 HP 230 Stage Submersible Pump

WELL HISTORY

Drilled in 1975 as infill well to Interstate Pudy Morrow Unit.
 IP of 500 BOPD and 1000 BWPD.
 Tubing is stuck in the hole.

1998 OCT 12 1:06 PM
 SASS ENERGY COMPANY



Kansas Corporation Commission

Bill Graves, Governor John Wine, Chair Susan M. Seltsam, Commissioner Cynthia L. Claus, Commissioner

NOTICE OF RECEIPT OF WELL PLUGGING APPLICATION (CP-1)

November 13, 1998

Anadarko Petroleum Company
PO Box 351
Liberal, Ks. 67905-0351

Interstate Unit #79
API 15-12920213
50'FWL SW/4
Sec. 21-34S-43W
Morton County

Dear Dave Gilmore,

This letter is to notify you that the Conservation Division is in receipt of your plugging proposal, form CP-1, for the above-captioned well.

Your CP-1 has been reviewed by the Conservation Division central office for completeness and to verify license numbers. The plugging proposal will now be forwarded to the district office listed below for review of your proposed method of plugging.

Please contact the district office for approval of your proposed plugging method at least at five (5) days before plugging the well, pursuant to K.A.R. 82-3-113 (b). If a workover pit will be used during the plugging of the well it must be permitted. A CDP-1 form must be filed and approved prior to the use of the pit.

The Conservation Division's review of form CP-1, either in the central or district office, does not include an inquiry into well ownership or the filing operator's legal right to plug the well.

This notice in no way constitutes authorization to plug the above-captioned well by persons not having legal rights of ownership or interest in the well. This notice is void after ninety (90) days from the above date.

Sincerely,

A handwritten signature in cursive script, appearing to read "David P. Williams".

David P. Williams
Production Supervisor

District: #1
304 W. McArtor
Dodge City, KS 67801
(316) 225-8888