

HALLIBURTON

SPECTRAL DENSITY DUAL SPACED NEUTRON LOG

COMPANY	SANDRIDGE ENERGY		
WELL	SIMONS 1736 1-12		
FIELD/BLOCK	BEAVER CLIFF NW		
COUNTY	WICHITA		
STATE	KANSAS		
COMPANY	SANDRIDGE ENERGY	API No.	15-203-20246
WELL	SIMONS 1736 1-12	Location	(SHL) 200 FNL & 2240' FEL
FIELD/BLOCK	BEAVER CLIFF NW		
COUNTY	WICHITA		
STATE	KANSAS		
Sect.	12	Twp.	17S
Rge.	36W		
Elev.	3221.0 ft		
D.F.	3229.0 ft		
G.L.	3221.0 ft		
Other Services:	DSN/SDL CSNG MICROLOG ACRT IDT/ICT WSTT MRIL		

Permanent Datum	GL	Elev.	K.B.	3230.0 ft
Log measured from	KB		D.F.	3229.0 ft
Drilling measured from	KB		G.L.	3221.0 ft
				9.0 ft above perm. Datum

Date	25-Nov-13	
Run No.	ONE	
Depth - Driller	5050.00 ft	
Depth - Logger	5046.0 ft	
Bottom - Logged Interval	5024	
Top - Logged Interval	1520	
Casing - Driller	9.625 in @ 1519.0 ft	
Casing - Logger	1520.0 ft	
Bit Size	8.750 in @	
Type Fluid in Hole	WATER BASED	
Density	9.3 ppq	44.00 s/qt
PH	11.70 pH	5.8 cp/m
Source of Sample	MUD PIT	
Rm @ Meas. Temperature	0.330 ohmm	@ 75.00 degF
Rmf @ Meas. Temperature	0.28 ohmm	@ 75.00 degF
Rmc @ Meas. Temperature	0.379 ohmm	@ 75.00 degF
Source Rmf	CALCULATED	CALCULATED
Rm @ BHT	0.21 ohmm	@ 119.0 degF
Time Since Circulation	8.0 hr	
Time on Bottom	25-Nov-13 06:33	
Max. Rec. Temperature	119.0 degF	@ 5046.0 ft
Equipment	11072142	LIBERAL
Recorded By	SHELDON INGERSOLL	
Witnessed By	P. BECKELHEIMER	

Fold here

Service Ticket No.: 900920751 API Serial No.: 15-203-20246 PGM Version: WL INSITE R3.8.4 (Build 5)

CHANGE IN MUD TYPE OR ADDITIONAL SAMPLE				RESISTIVITY SCALE CHANGES				
Date	Sample No.			Type Log	Depth	Scale Up Hole	Scale Down Hole	
Depth-Driller								
Type Fluid in Hole								
Density	Viscosity							
Ph	Fluid Loss							
Source of Sample				RESISTIVITY EQUIPMENT DATA				
Rm @ Meas. Temp		@	@	Run No.	Tool Type & No.	Pad Type	Tool Pos.	Other
Rmf @ Meas. Temp.		@	@	ONE	ACRT	N/A	1.5" S.O.	
Rmc @ Meas. Temp.		@	@		11005909			
Source Rmf	Rmc							
Rm @ BHT		@	@					
Rmf @ BHT		@	@					
Rmc @ BHT		@	@					

EQUIPMENT DATA

GAMMA		ACOUSTIC		DENSITY		NEUTRON	
Run No.	ONE	Run No.	ONE	Run No.	ONE	Run No.	ONE
Serial No.	11021139	Serial No.	10753396	Serial No.	10865884	Serial No.	11055304
Model No.	GTET	Model No.	WSTT	Model No.	SDLT	Model No.	DSNT
Diameter	3.625"	No. of Cent.	2	Diameter	5.3"	Diameter	3.625"
Detector Model No.	T-102	Spacing	.5'	Log Type	GAM-GAM	Log Type	NEU-NEU
Type	SCINT			Source Type	CS-137	Source Type	AM-241BE
Length	8"	LSA [Y/N]	YES	Serial No.	5168GW	Serial No.	DSN-424
Distance to Source	N/A	FWDA [Y/N]	YES	Strength	1.5 CI	Strength	15 CI

LOGGING DATA

GENERAL			GAMMA		ACOUSTIC		DENSITY			NEUTRON				
Run No.	Depth		Speed	Scale		Scale		Matrix	Scale		Matrix	Scale		Matrix
	From	To	ft/min	L	R	L	R		L	R		L	R	
ONE	5046	1520	REC	0	150	30	-10	47.6 us/ft	30	-10	2.71 gm/cc	30	-10	LIME

DIRECTIONAL INFORMATION

Maximum Deviation	@	KOP	@
-------------------	---	-----	---

Remarks: ANNULAR HOLE VOLUME CALCULATED FOR 7 INCH CASING.

CHLORIDES REPORTED AT 18,000 mg/L.

HALLIBURTON DOES NOT GUARANTEE THE ACCURACY OF ANY INTERPRETATION OF THE LOG DATA, CONVERSION OF LOG DATA TO PHYSICAL ROCK PARAMETERS OR RECOMMENDATIONS WHICH MAY BE GIVEN BY HALLIBURTON PERSONNEL OR WHICH APPEAR ON THE LOG OR IN ANY OTHER FORM. ANY USER OF SUCH DATA, INTERPRETATIONS, CONVERSIONS, OR RECOMMENDATIONS AGREES THAT HALLIBURTON IS NOT RESPONSIBLE EXCEPT WHERE DUE TO GROSS NEGLIGENCE OR WILLFUL MISCONDUCT, FOR ANY LOSS, DAMAGES, OR EXPENSES RESULTING FROM THE USE THEREOF.

HALLIBURTON



Plot Time: 25-Nov-13 15:43:23
 Plot Range: 1495.75 ft to 5049.75 ft
 Data: SIMONS_1736_112\Well Based\R1 CASING\
 Plot File: \\POROSITY\Porosity_IQ_5_MAIN_LIB

5 INCH MAIN LOG

<div style="background-color: #cccccc; border: 1px solid black; padding: 2px; text-align: center;">CROSSOVER</div>		30	Neutron Porosity	-10				
			%					
<div style="background-color: #cccccc; border: 1px solid black; padding: 2px; text-align: center;">SHALE</div>		30	Density Porosity	-10				
			%					
0	Gamma API	150	AHVT 15K Tension pounds	0				
	api							
6	Caliper	16	MD 1 : 240 ft	0				
	inches							
			0	Pe	10	-0.25	Density Corr	0.25
							gram per cc	

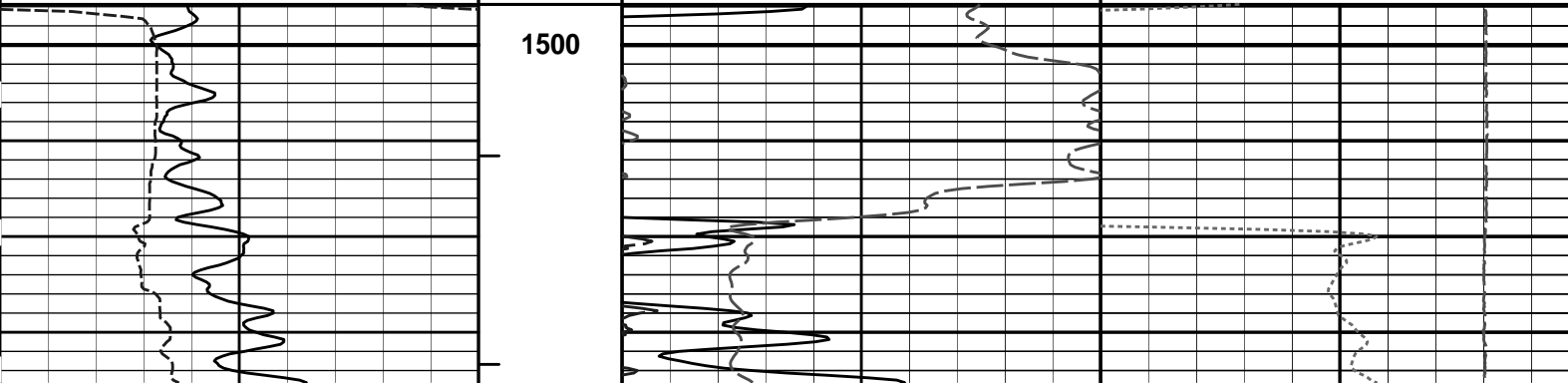

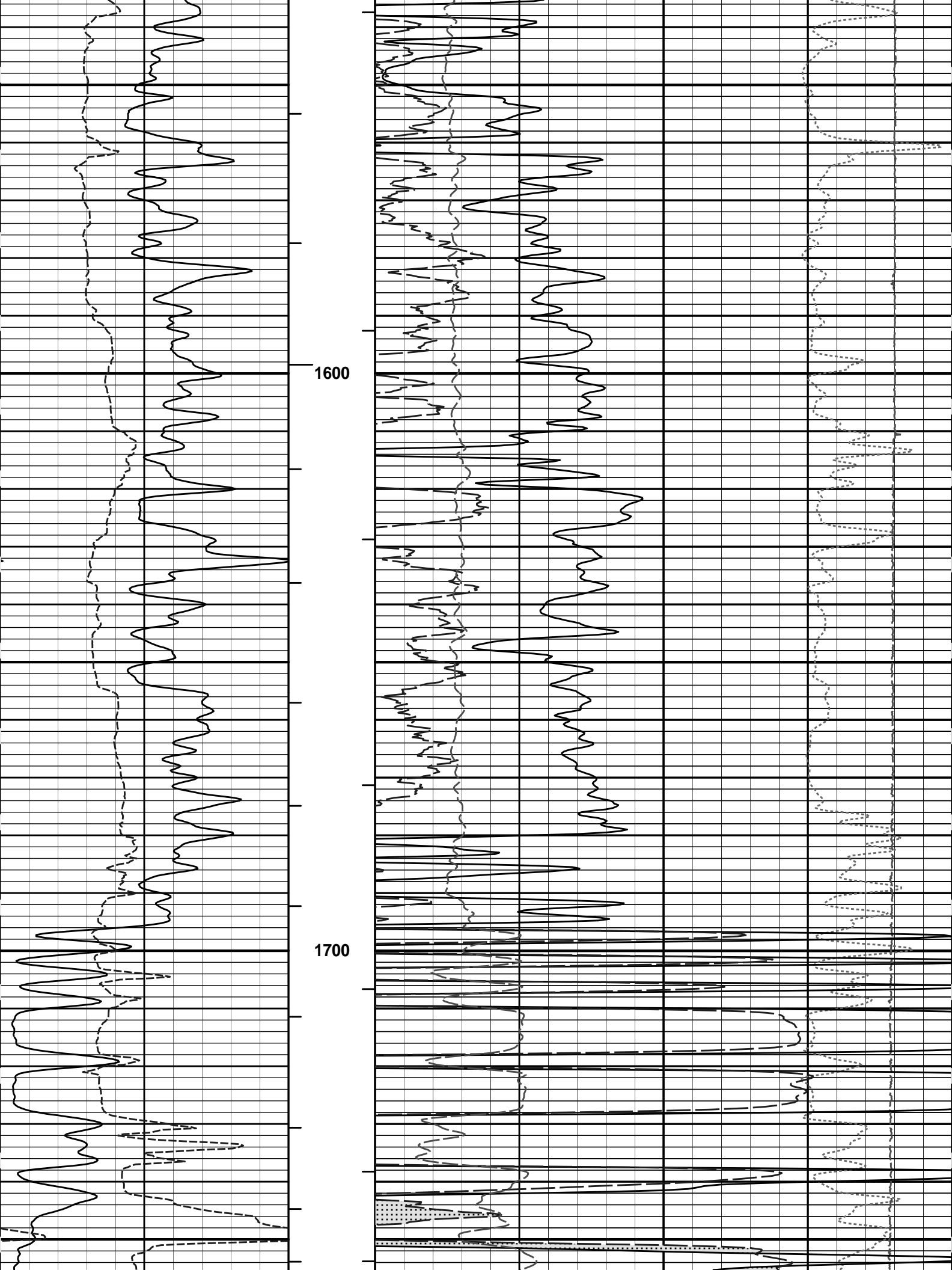

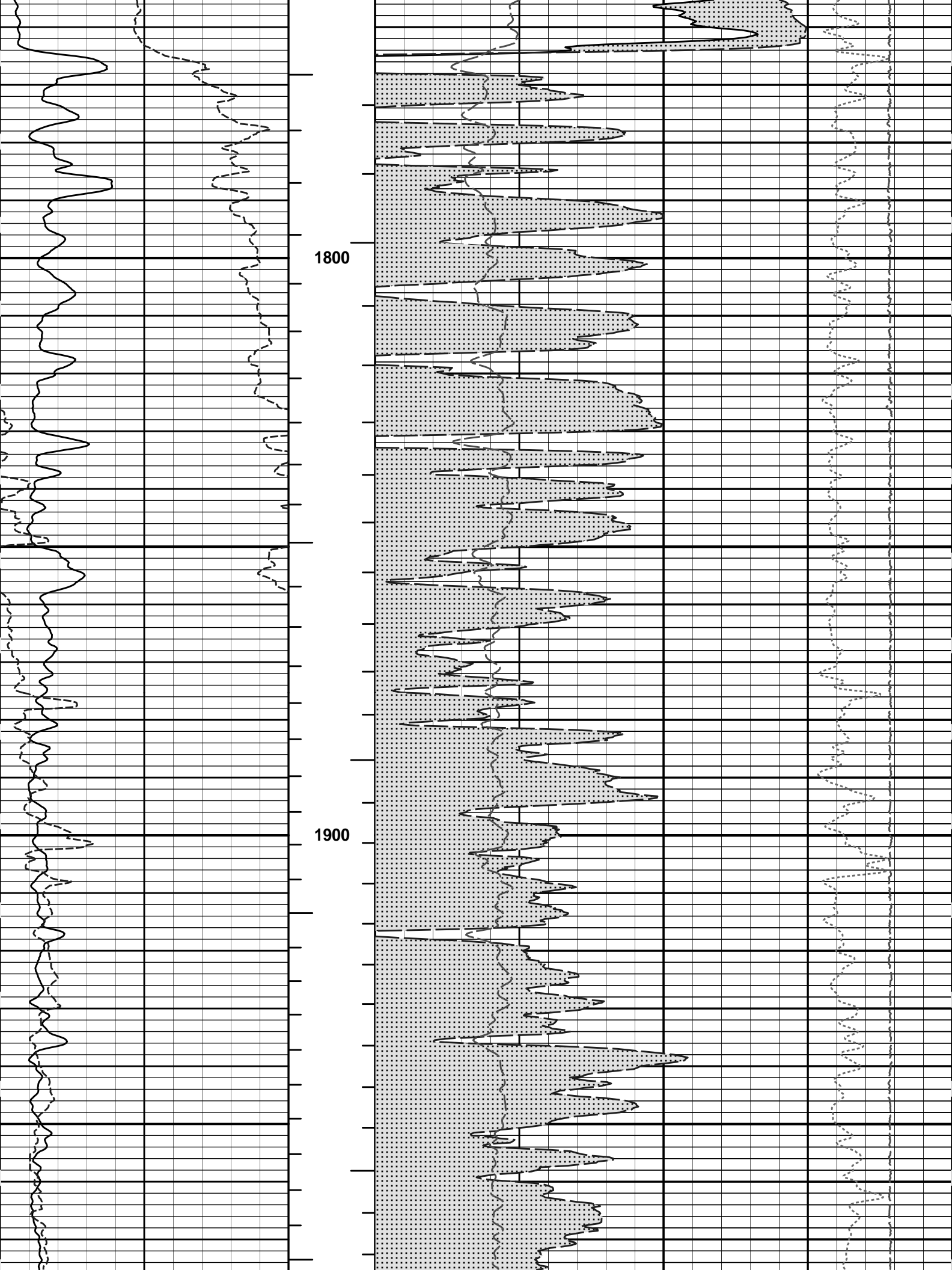

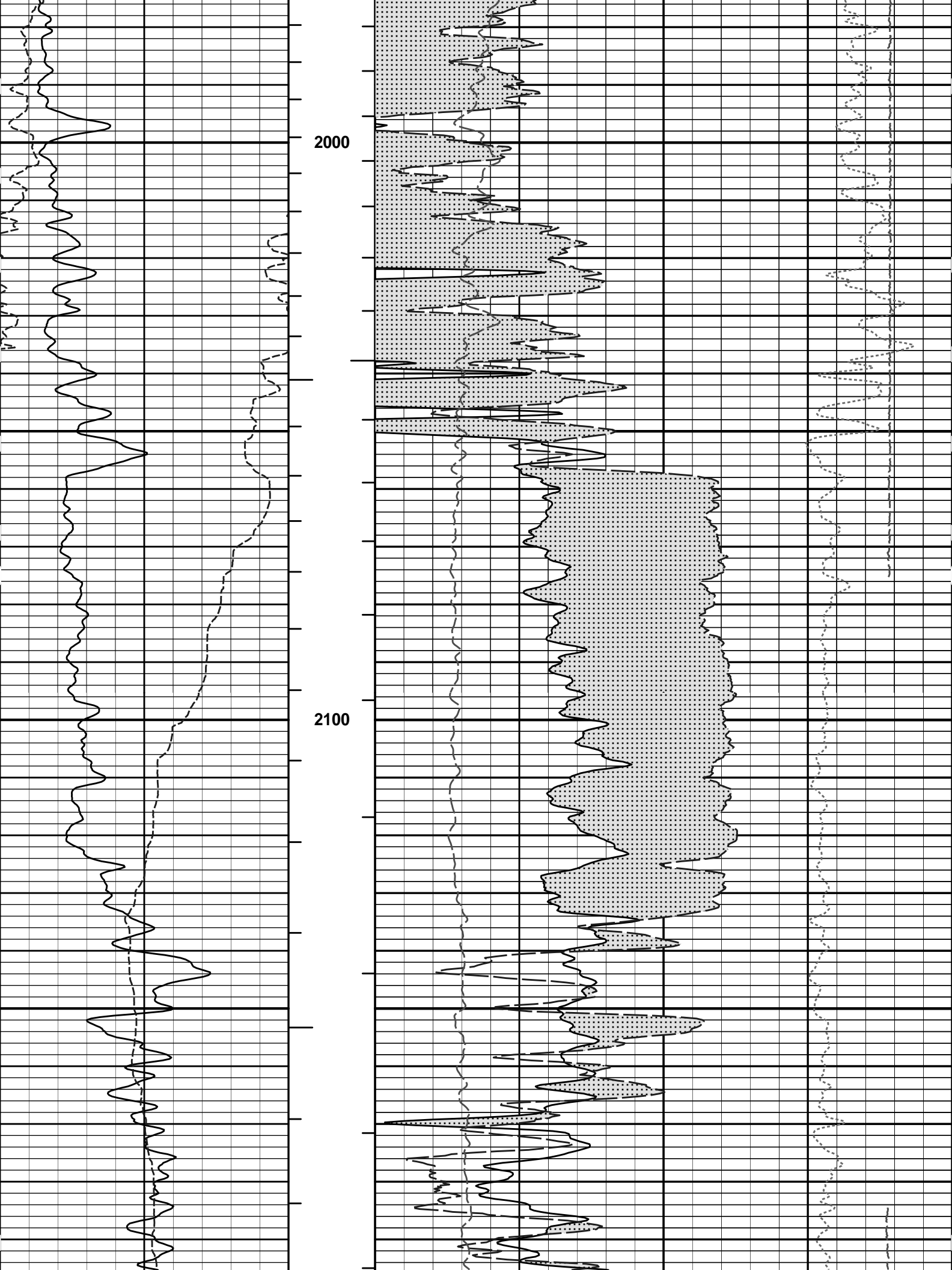

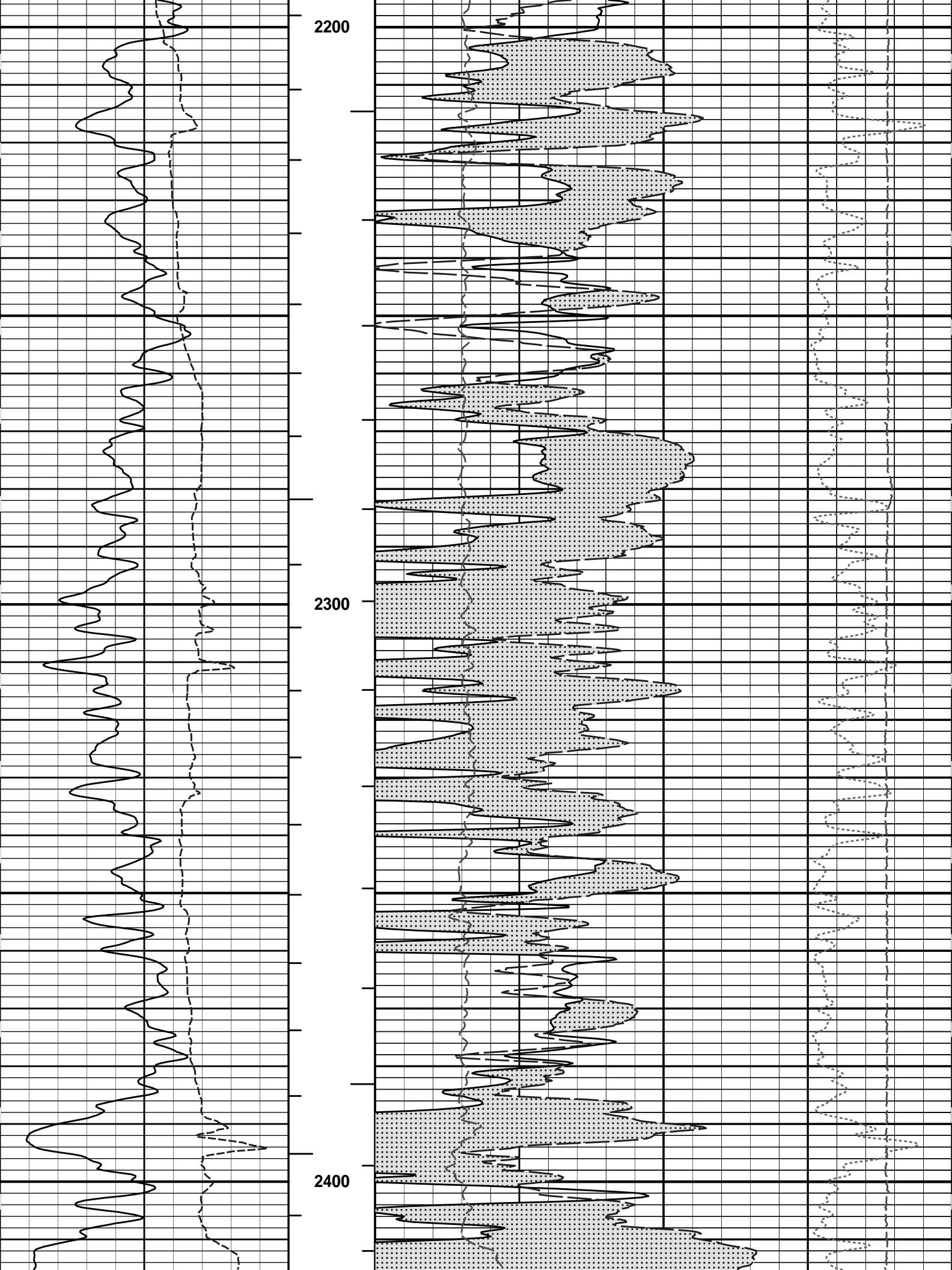

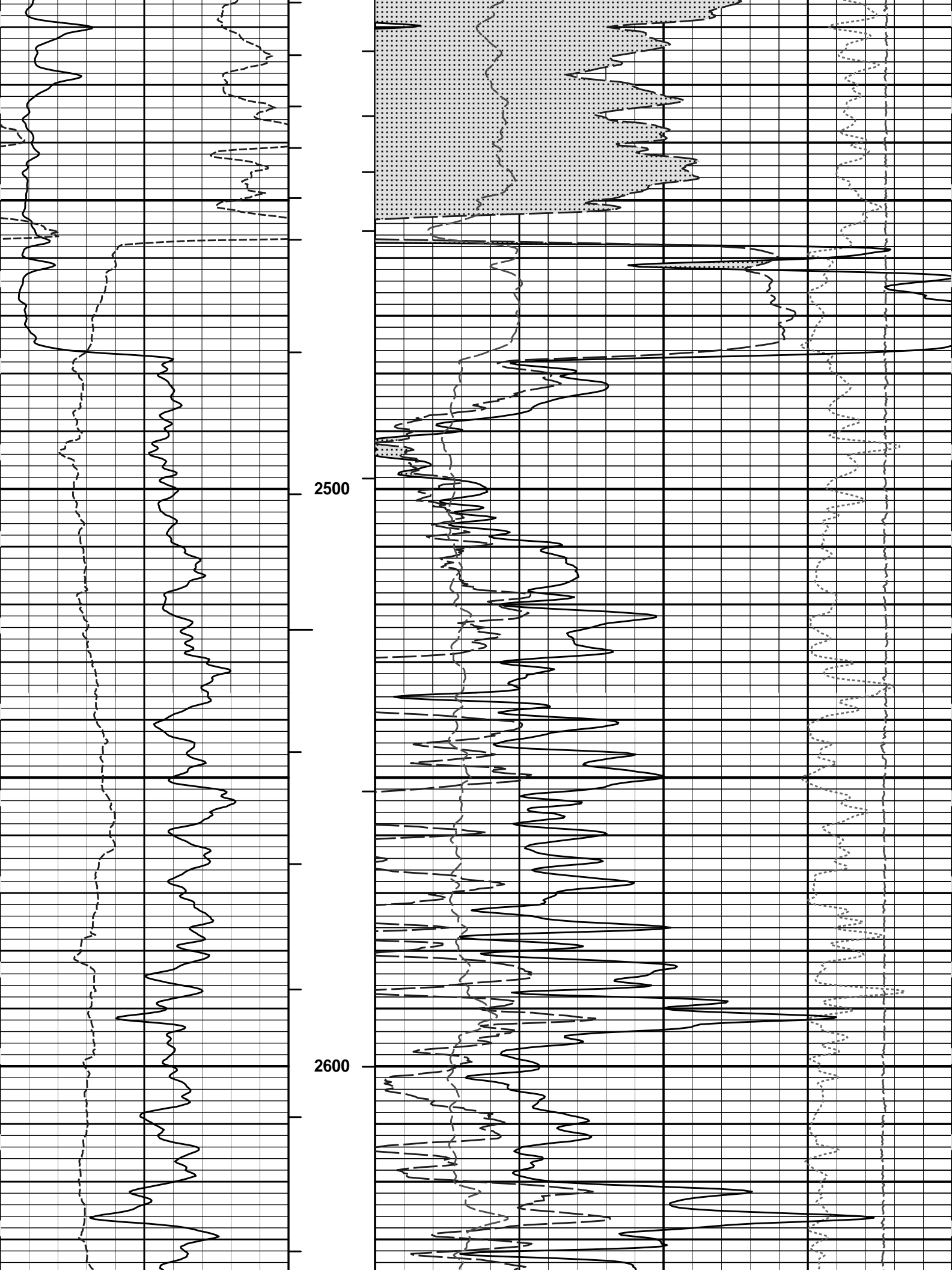

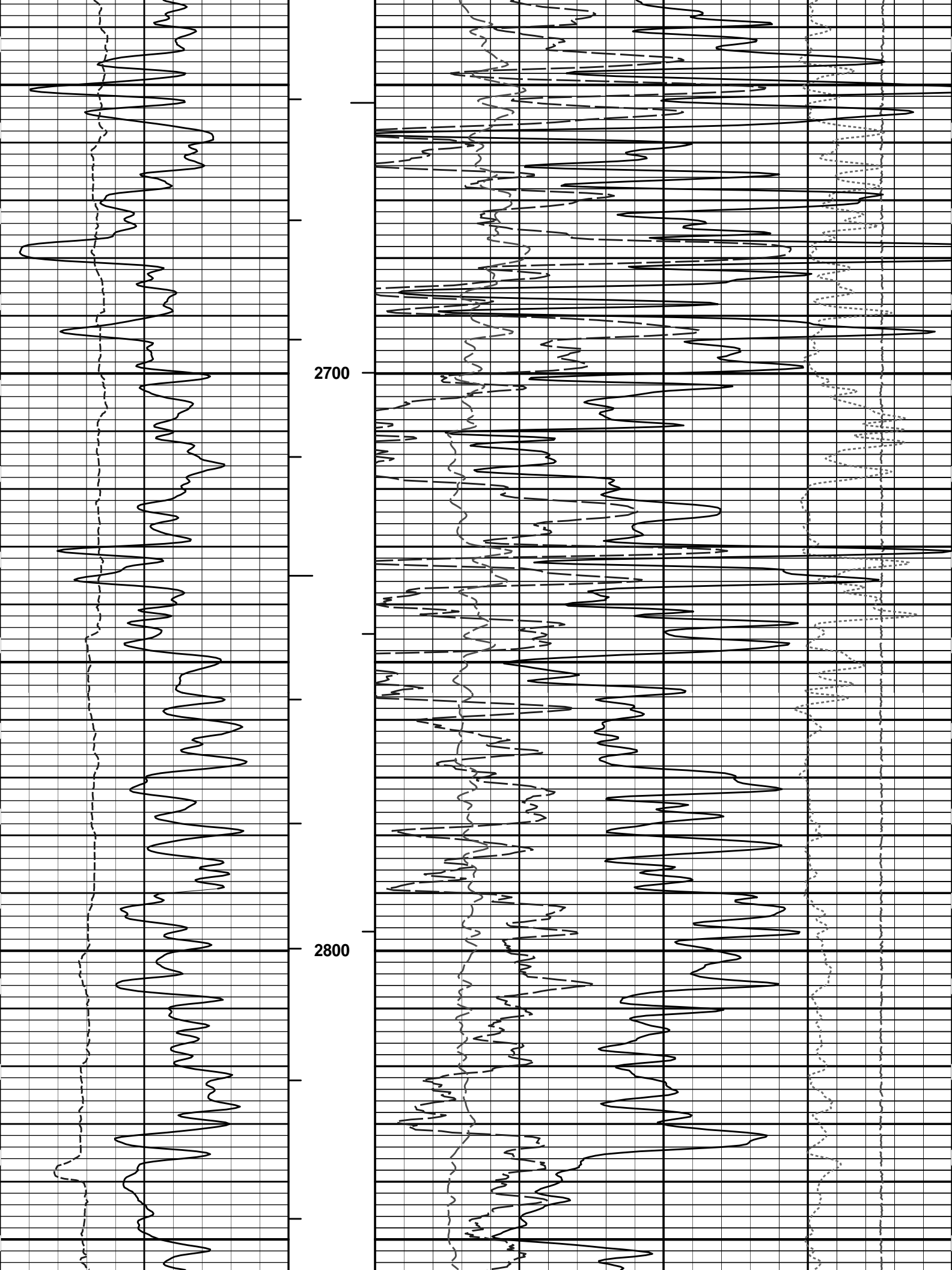

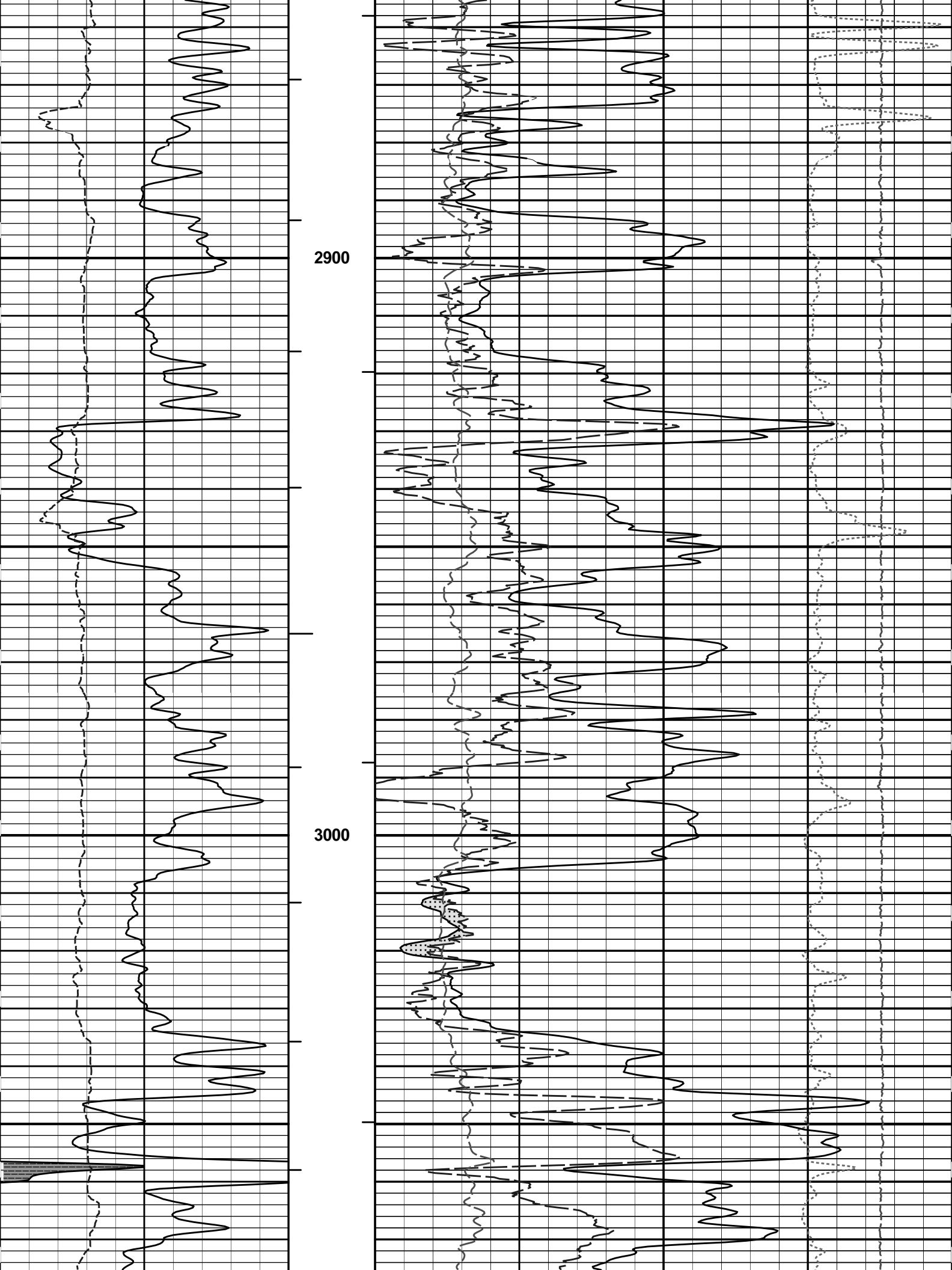

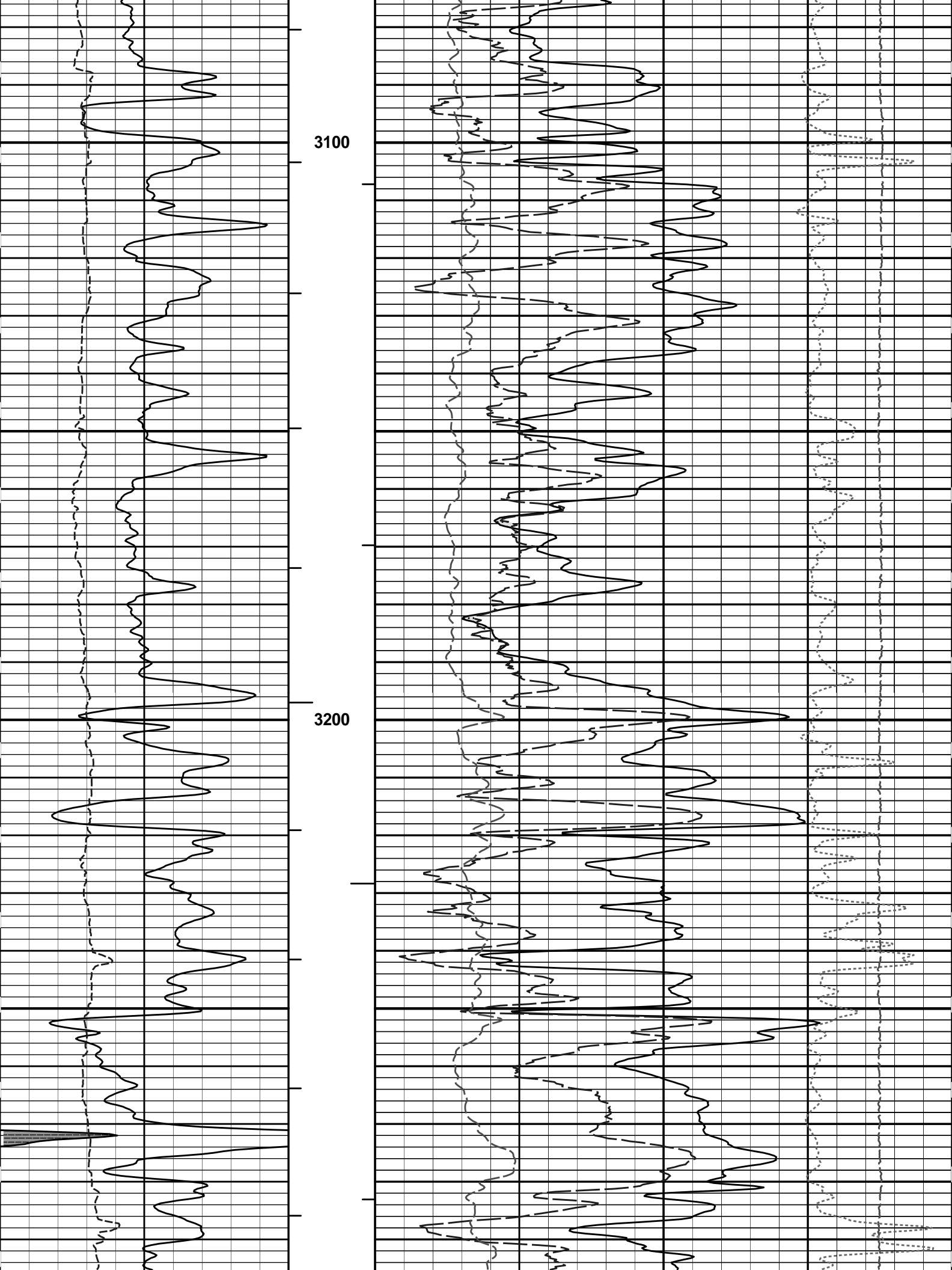

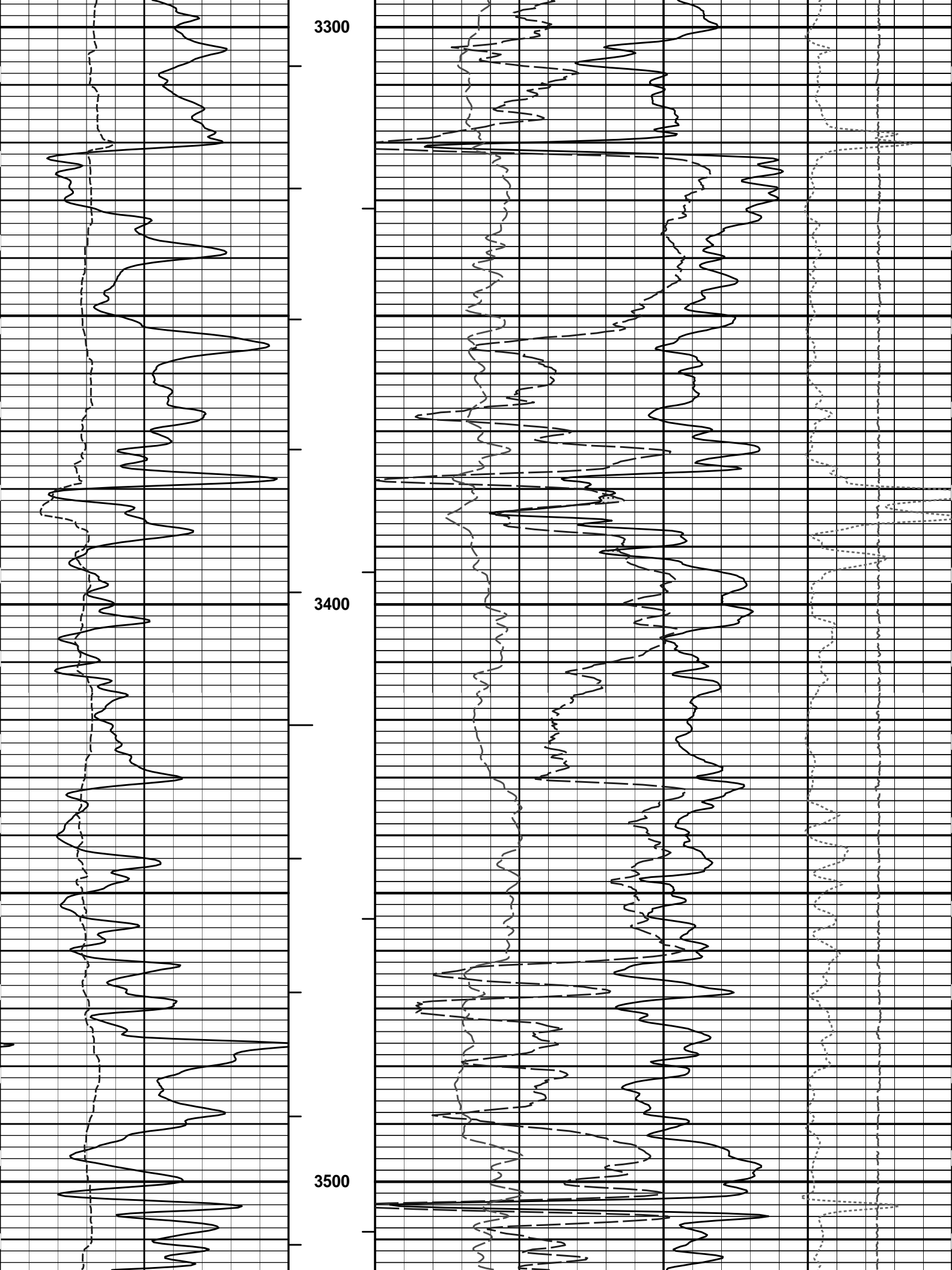

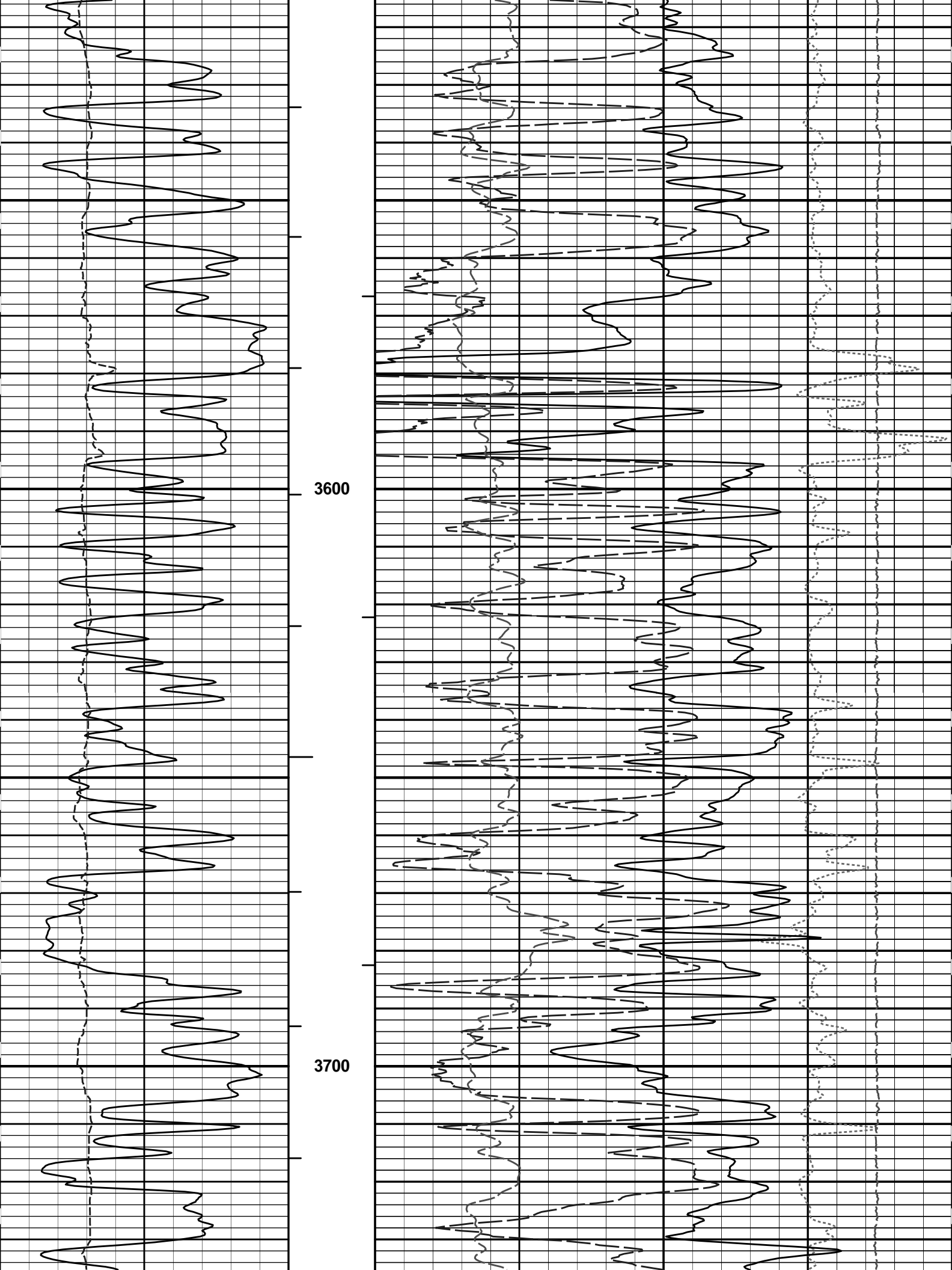

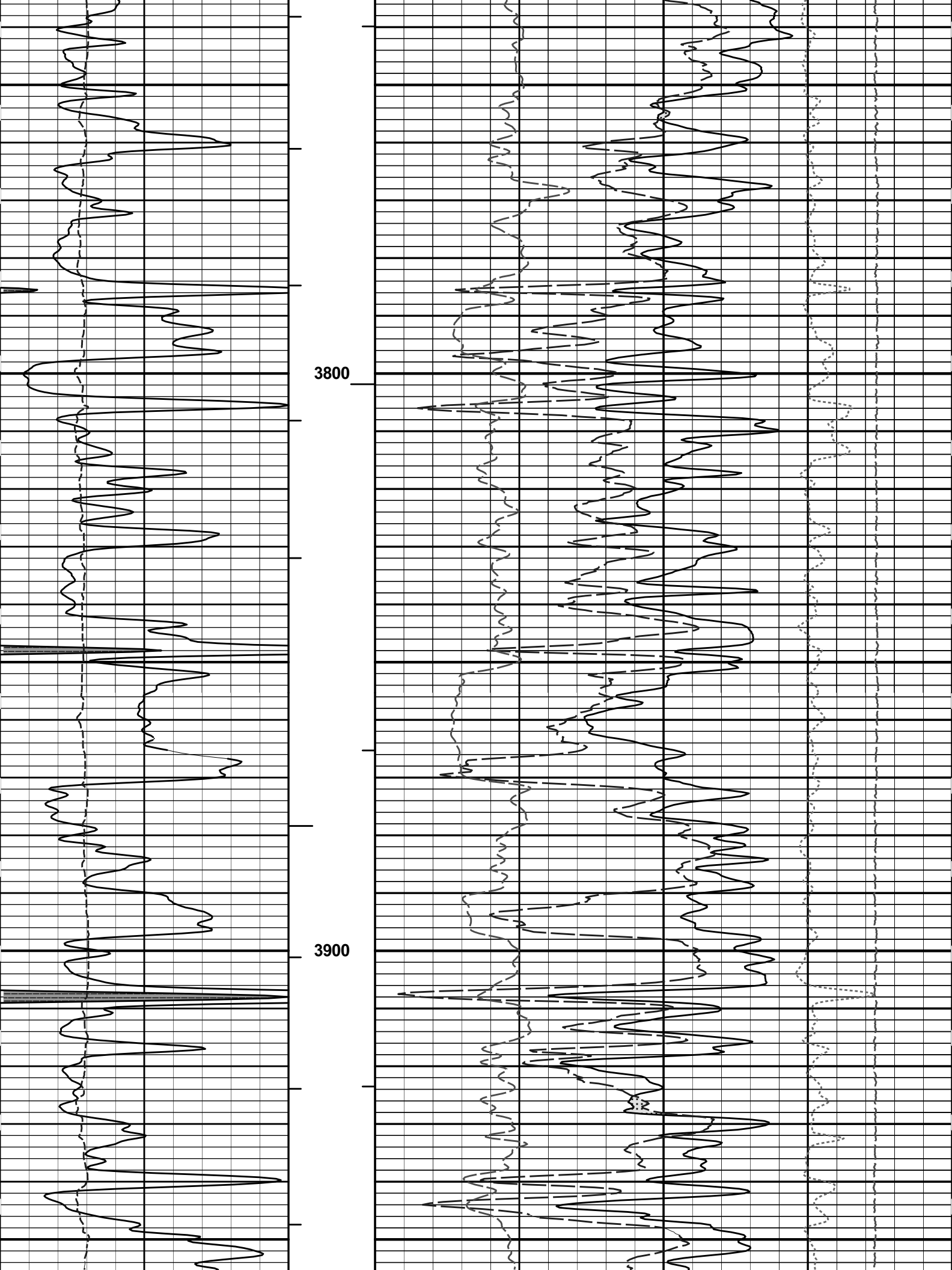

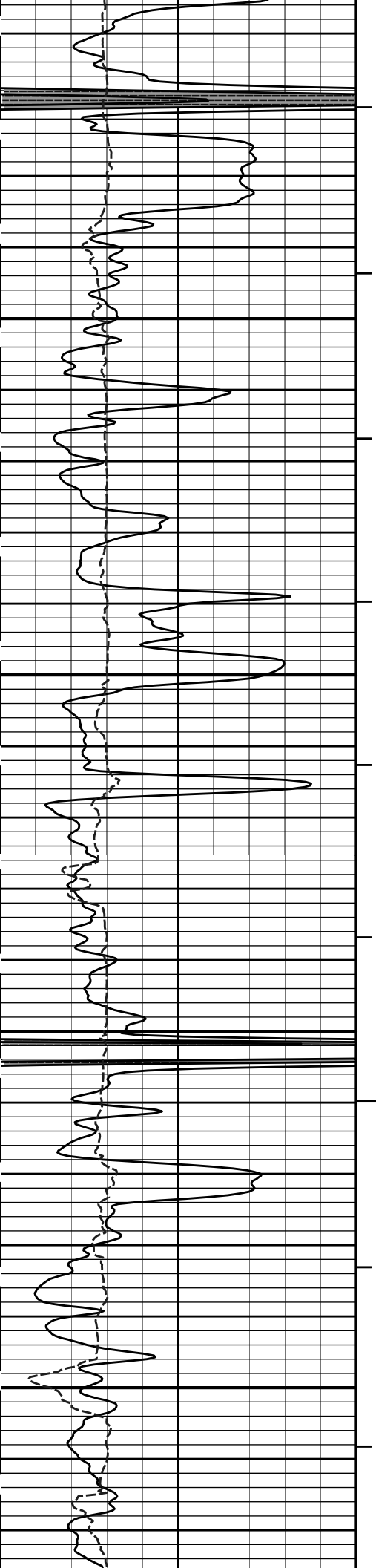

4000

4100

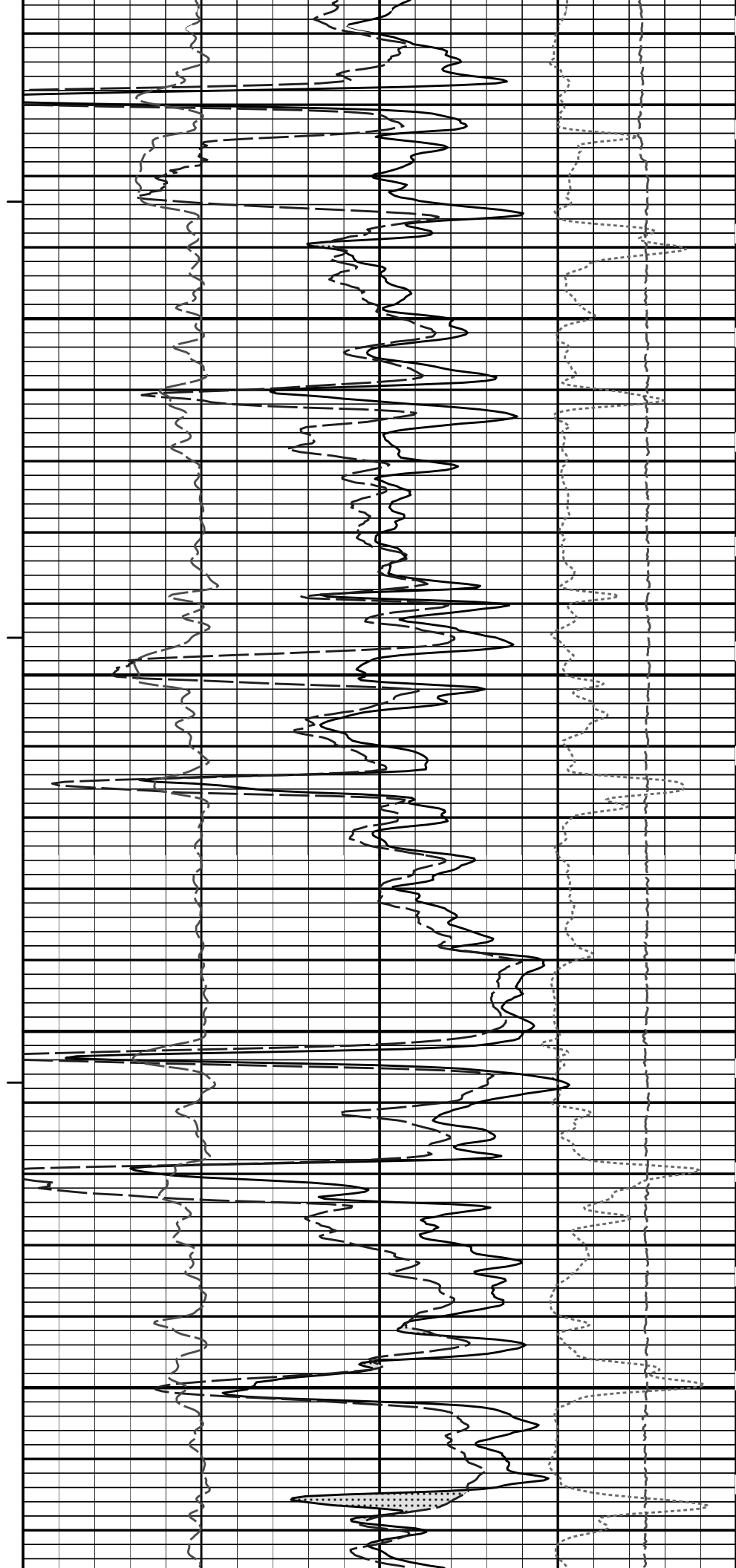

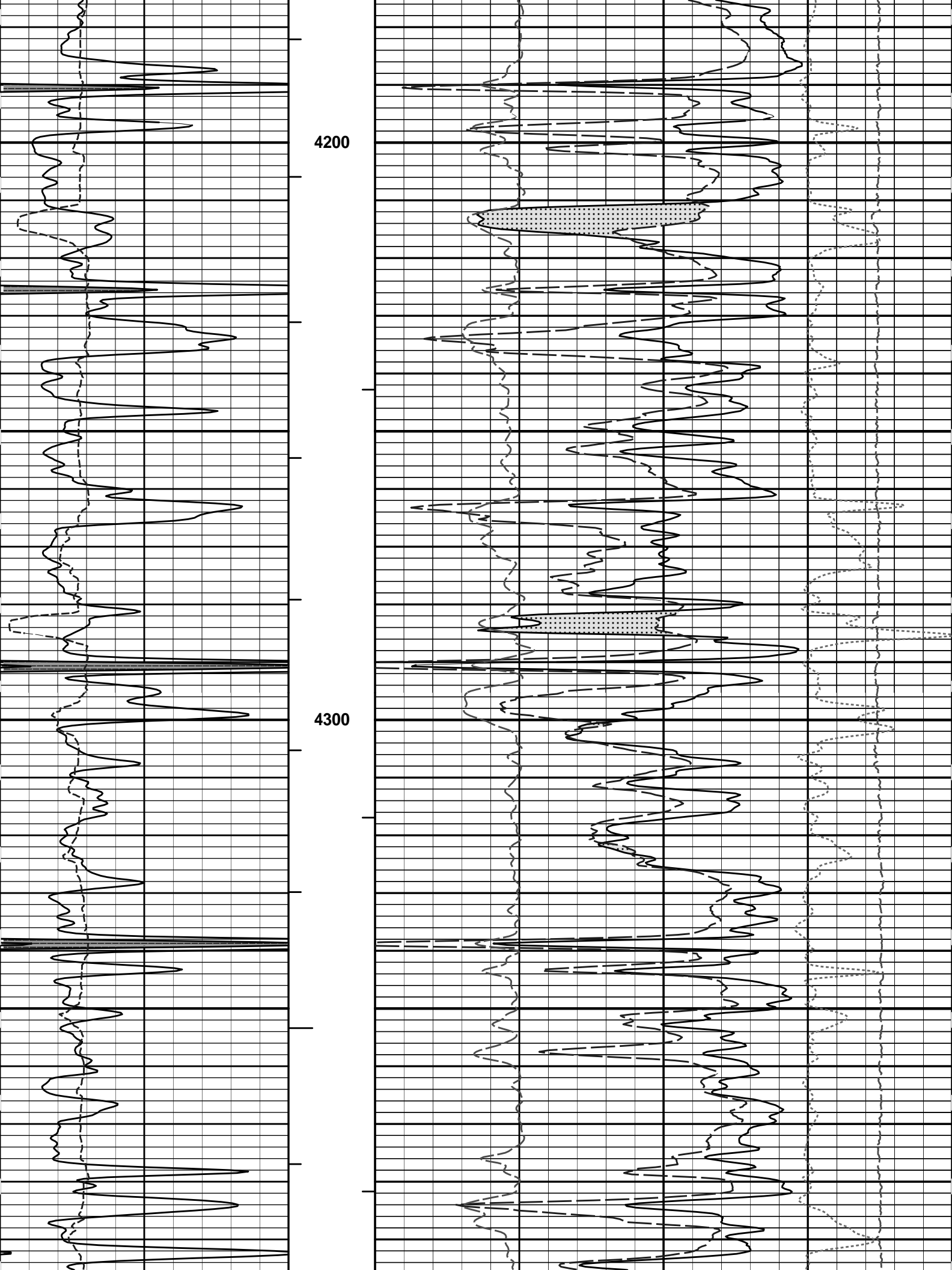

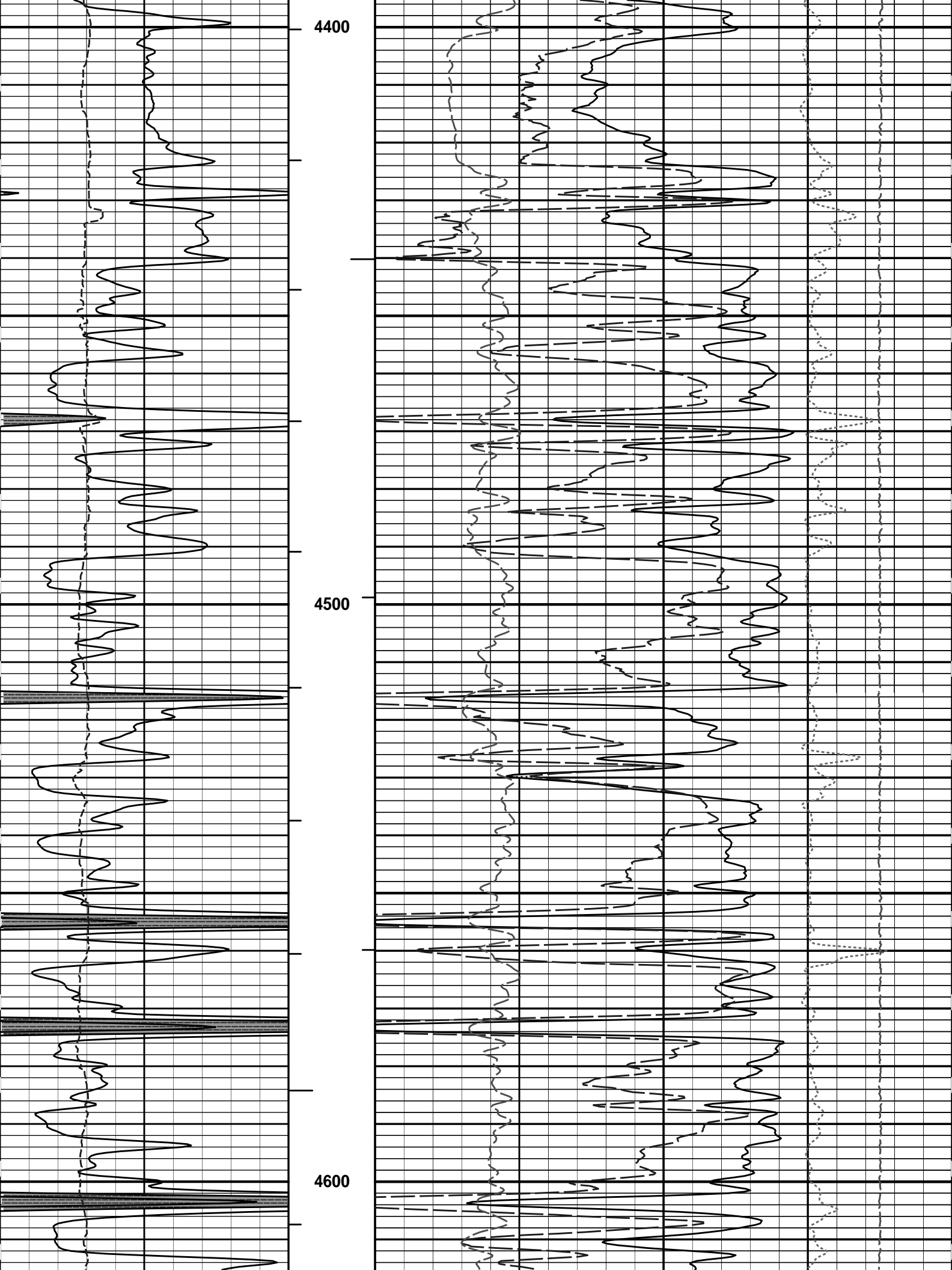

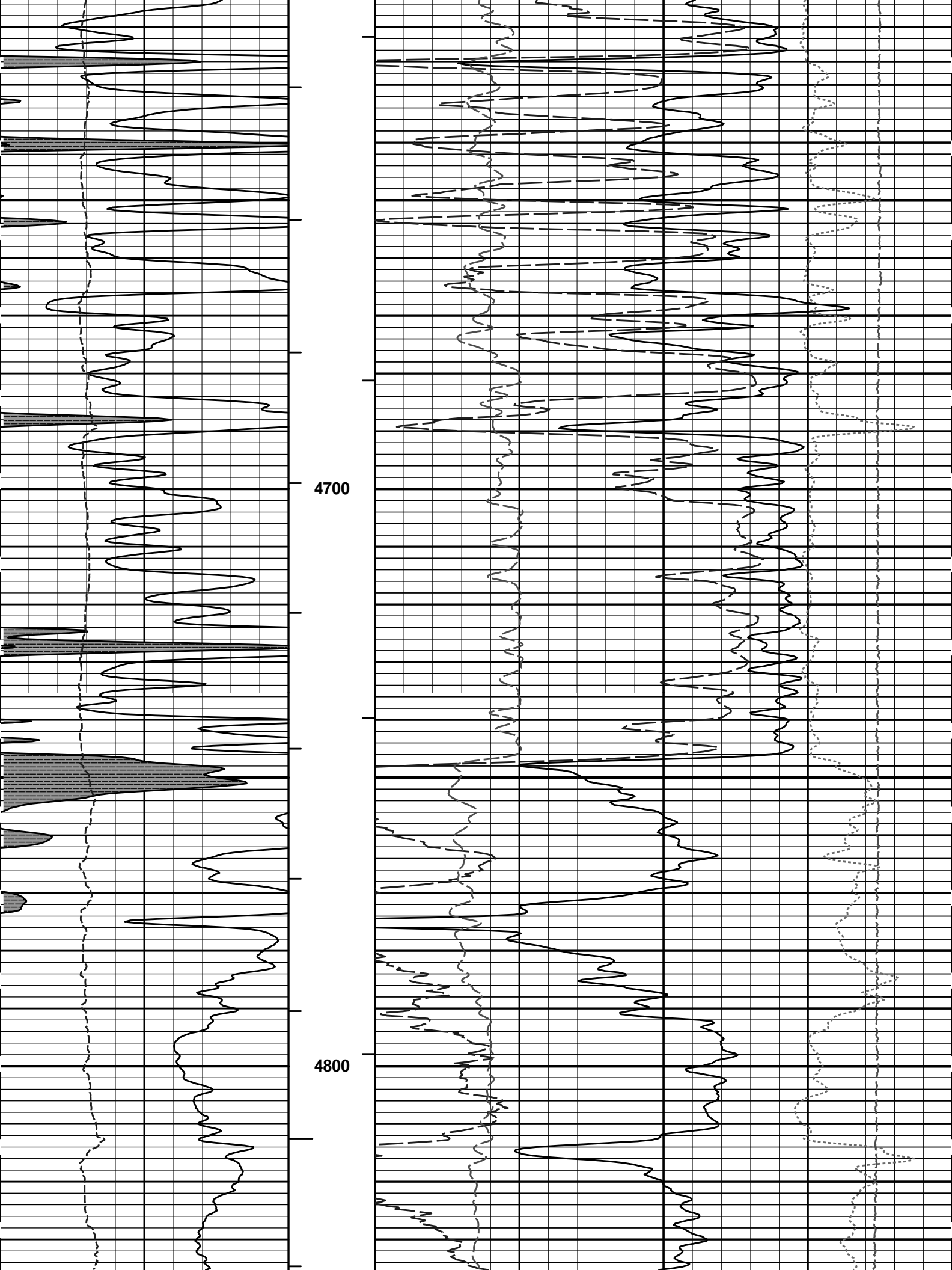

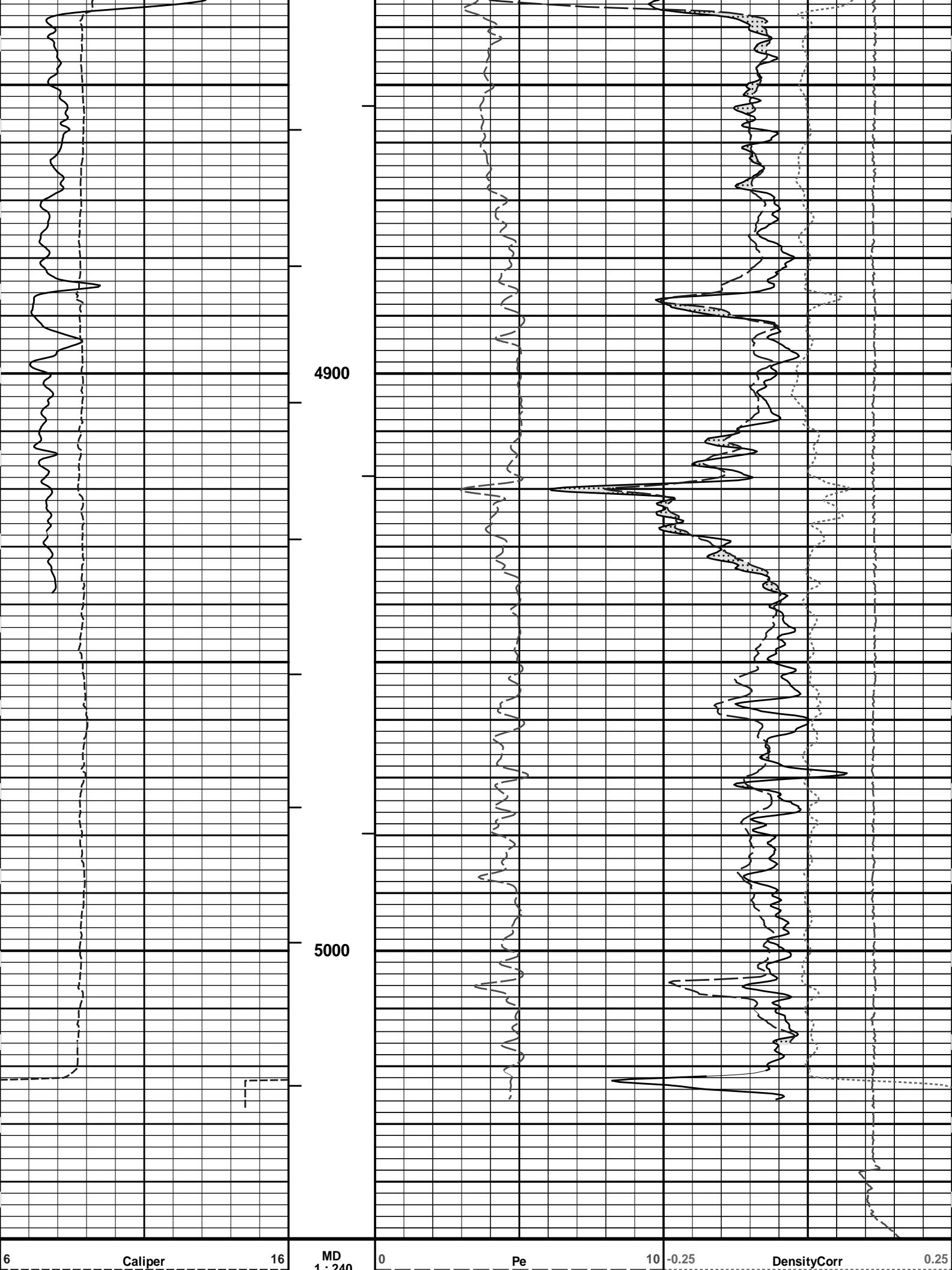

6 Caliper 16 MD 1:240 0 Pe 10 -0.25 DensityCorr 0.25

inches	ft	gram per cc
0	150	15K
Gamma API	AHVT	Tension
api		pounds
SHALE	BHVT	DensityPorosity
		%
		Neutron Porosity
		%
		CROSSOVER

HALLIBURTON

Plot Time: 25-Nov-13 15:43:58
 Plot Range: 1495.75 ft to 5049.75 ft
 Data: SIMONS_1736_112\Well Based\R1 CASING\
 Plot File: \\POROSITY\Poro_IQ_5_MAIN_LIB

5 INCH MAIN LOG

HALLIBURTON

Plot Time: 25-Nov-13 15:43:58
 Plot Range: 4595.5 ft to 5044.67 ft
 Data: SIMONS_1736_112\Well Based\R1 REPEAT\
 Plot File: \\POROSITY\Poro_IQ_5_REP_LIB

REPEAT SECTION

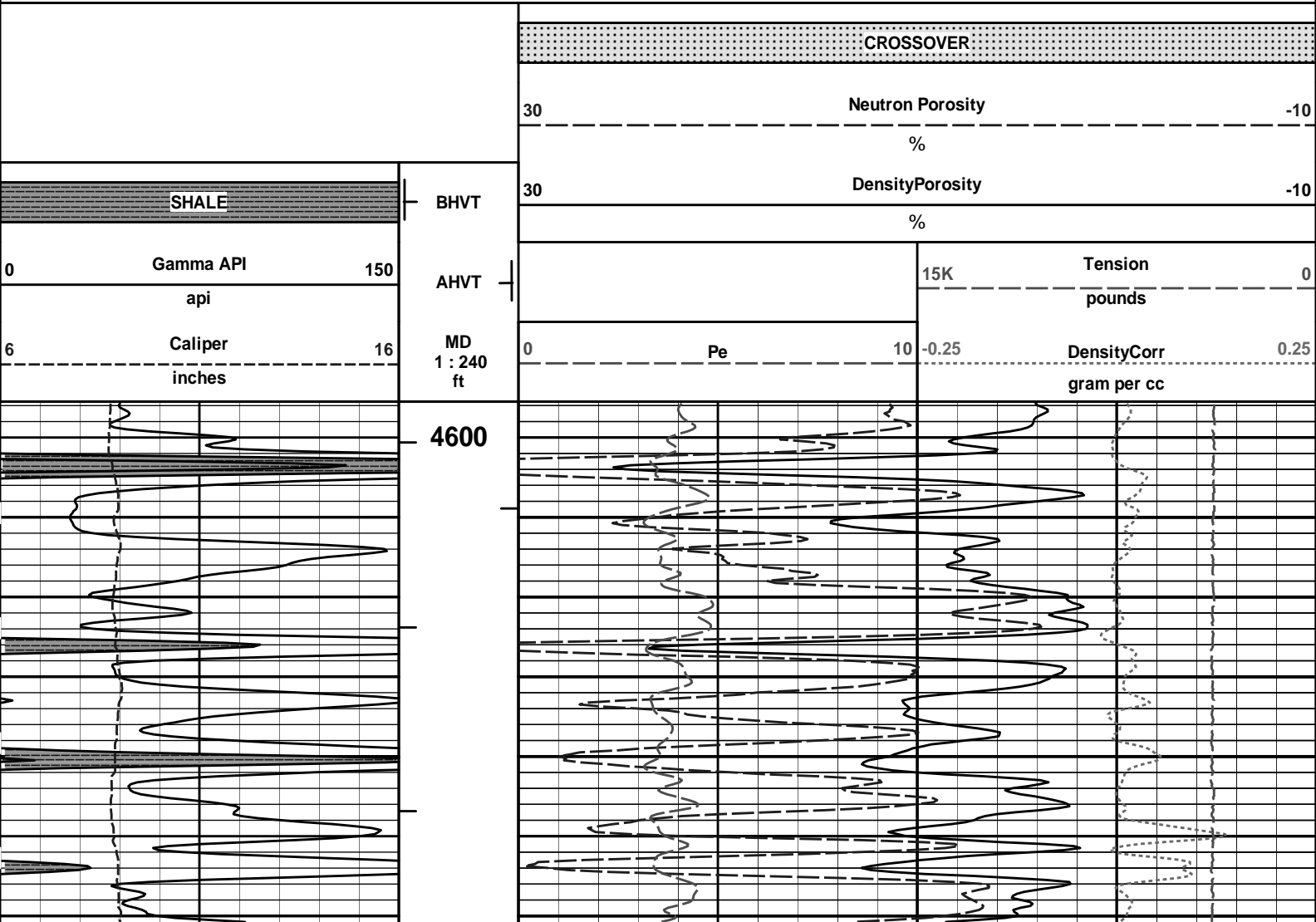

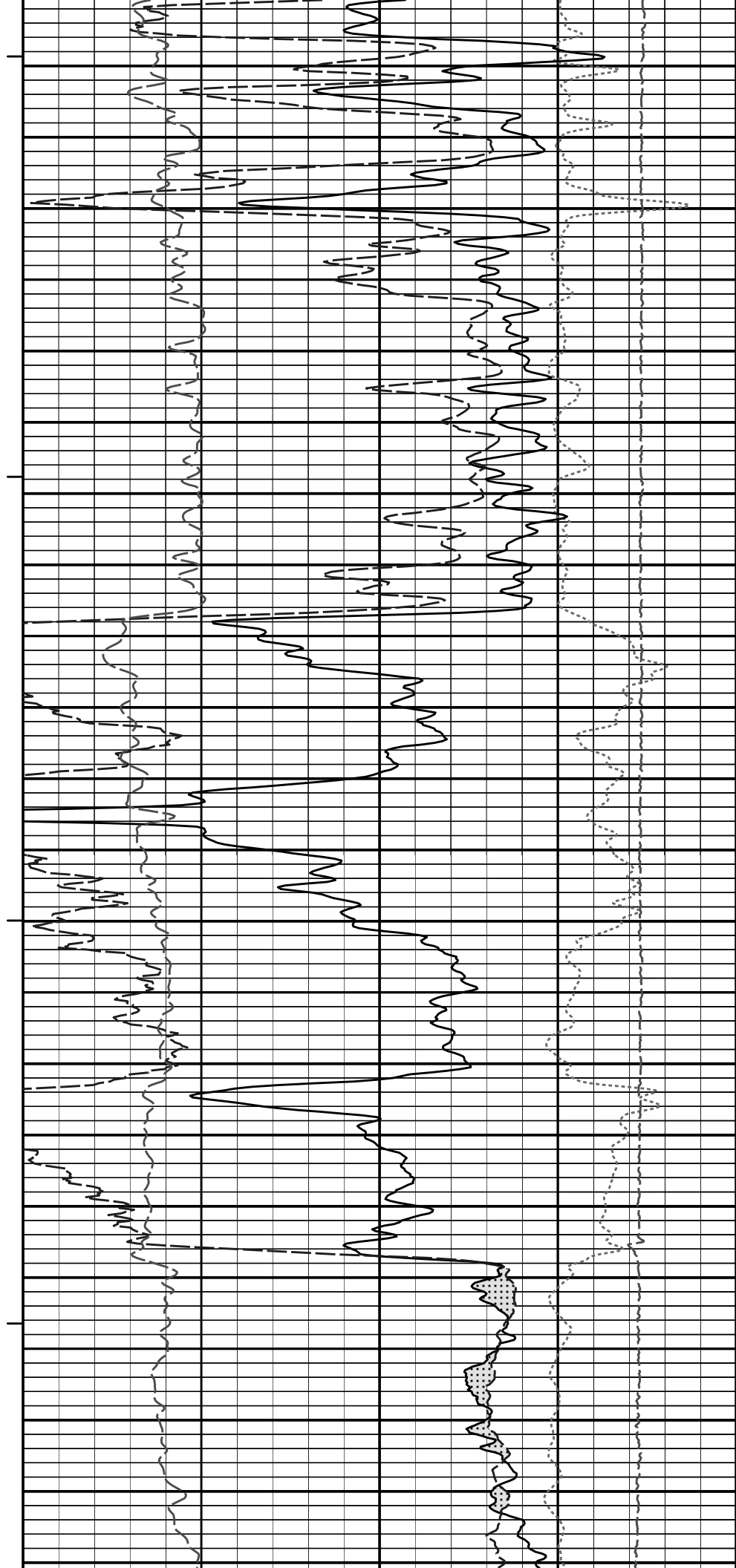
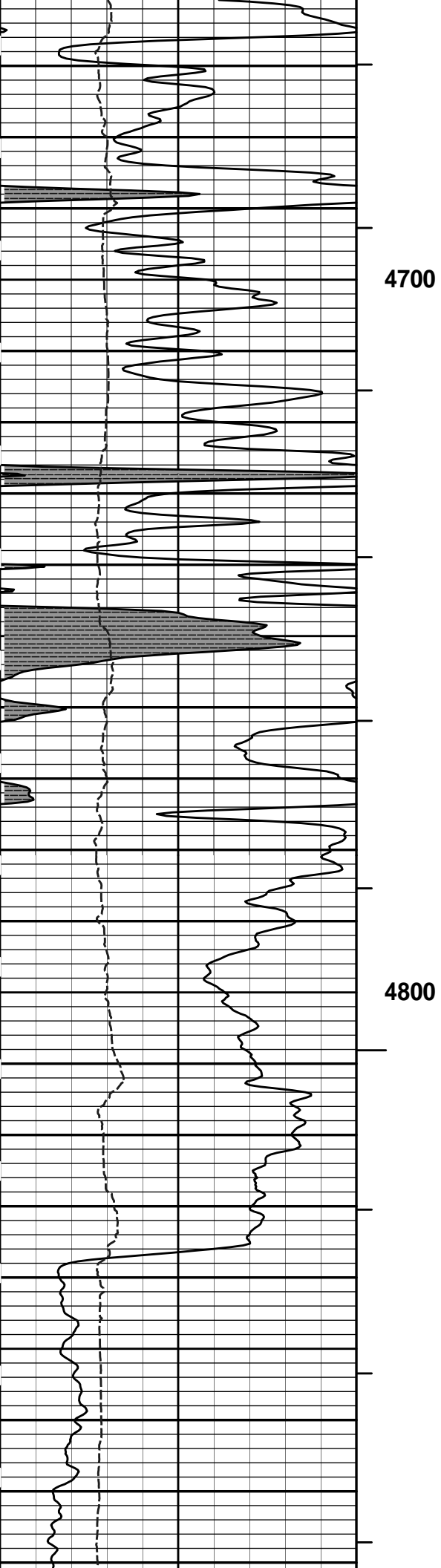

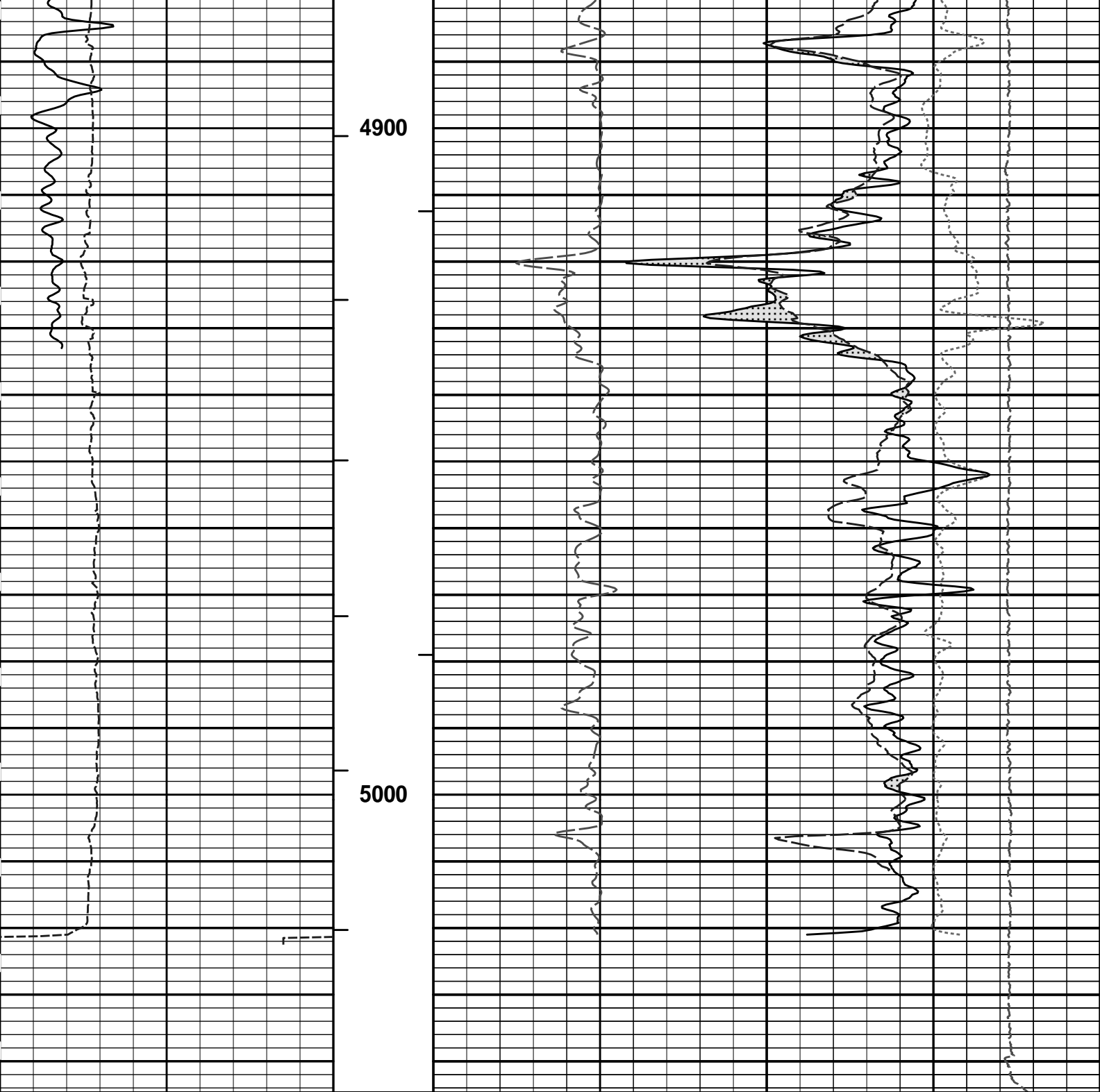

4900

5000

6	Caliper	16	MD	1 : 240	0	Pe	10	-0.25	DensityCorr	0.25
	inches		ft						gram per cc	
0	Gamma API	150	AHVT					15K	Tension	0
	api								pounds	
	SHALE		BHVT		30	DensityPorosity				-10
						%				
					30	Neutron Porosity				-10
						%				
						CROSSOVER				

REPEAT SECTION

HALLIBURTON

Plot Time: 25-Nov-13 15:44:03
 Plot Range: 1495.75 ft to 5049.75 ft
 Data: SIMONS_1736_112\Well Based\R1 CASING\
 Plot File: \\LOCAL-SIMONS_1736_112\Well Based\POROSITY\BULKD_5_MAIN_LIB

5 INCH MAIN LOG

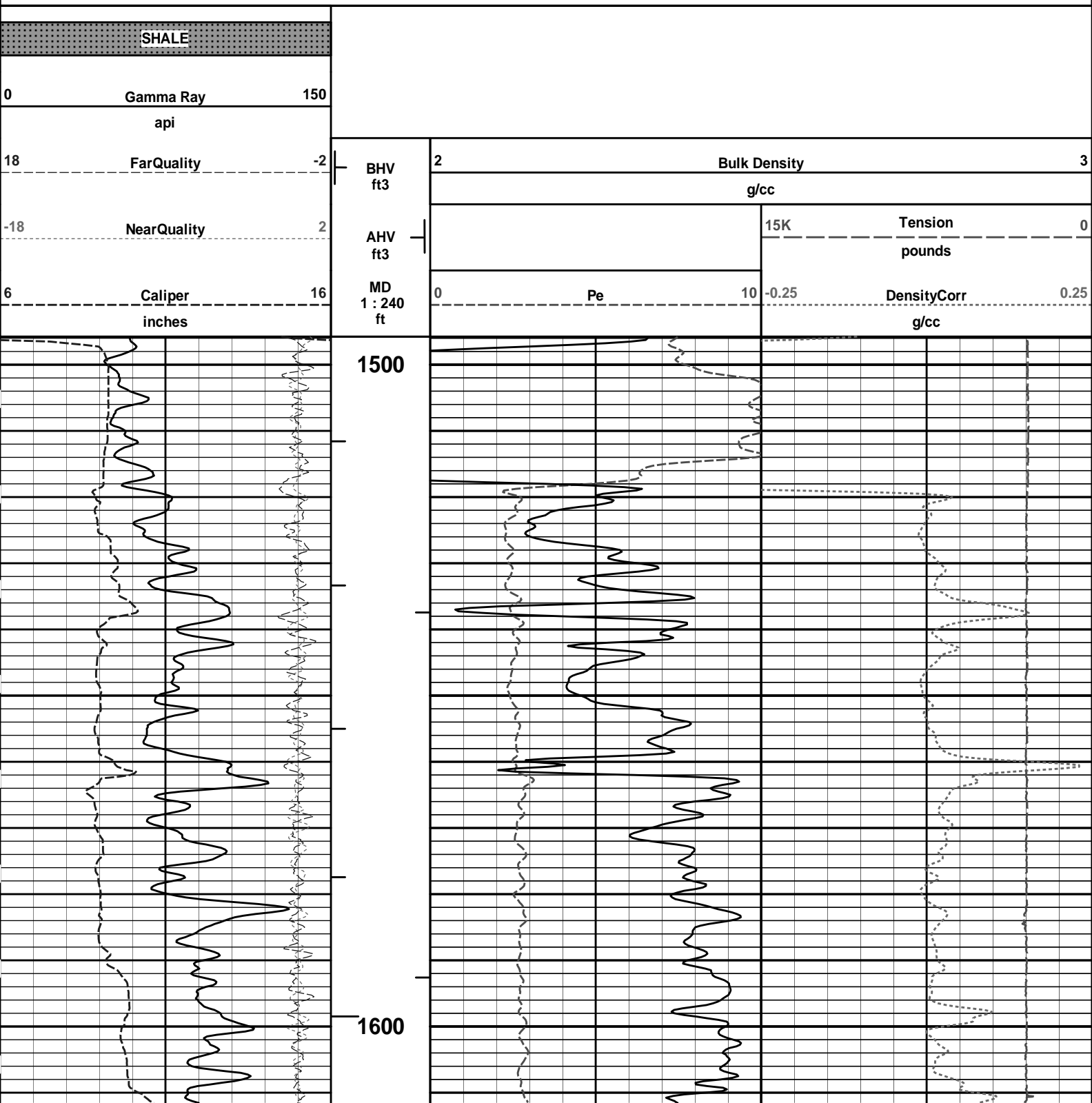

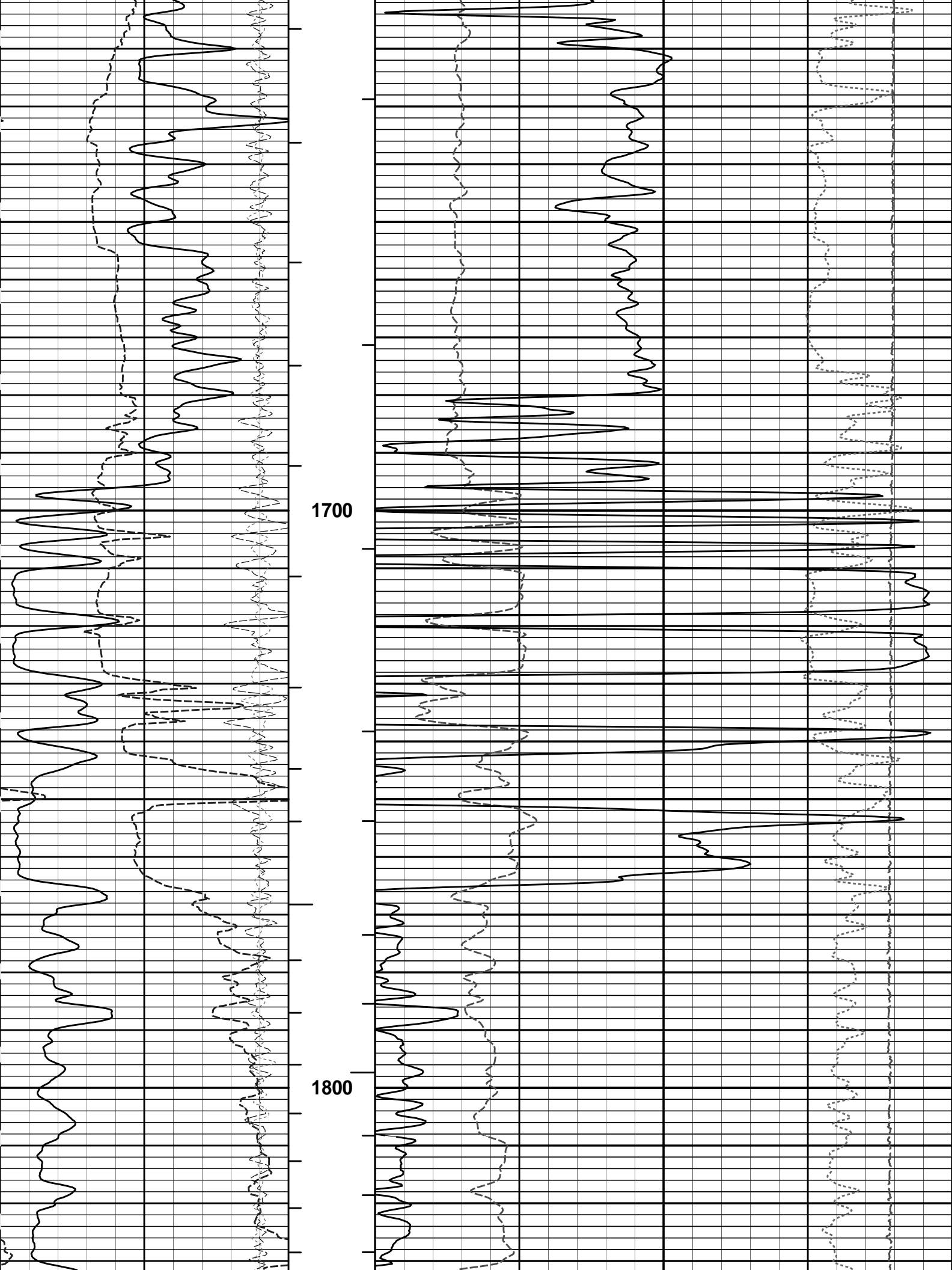

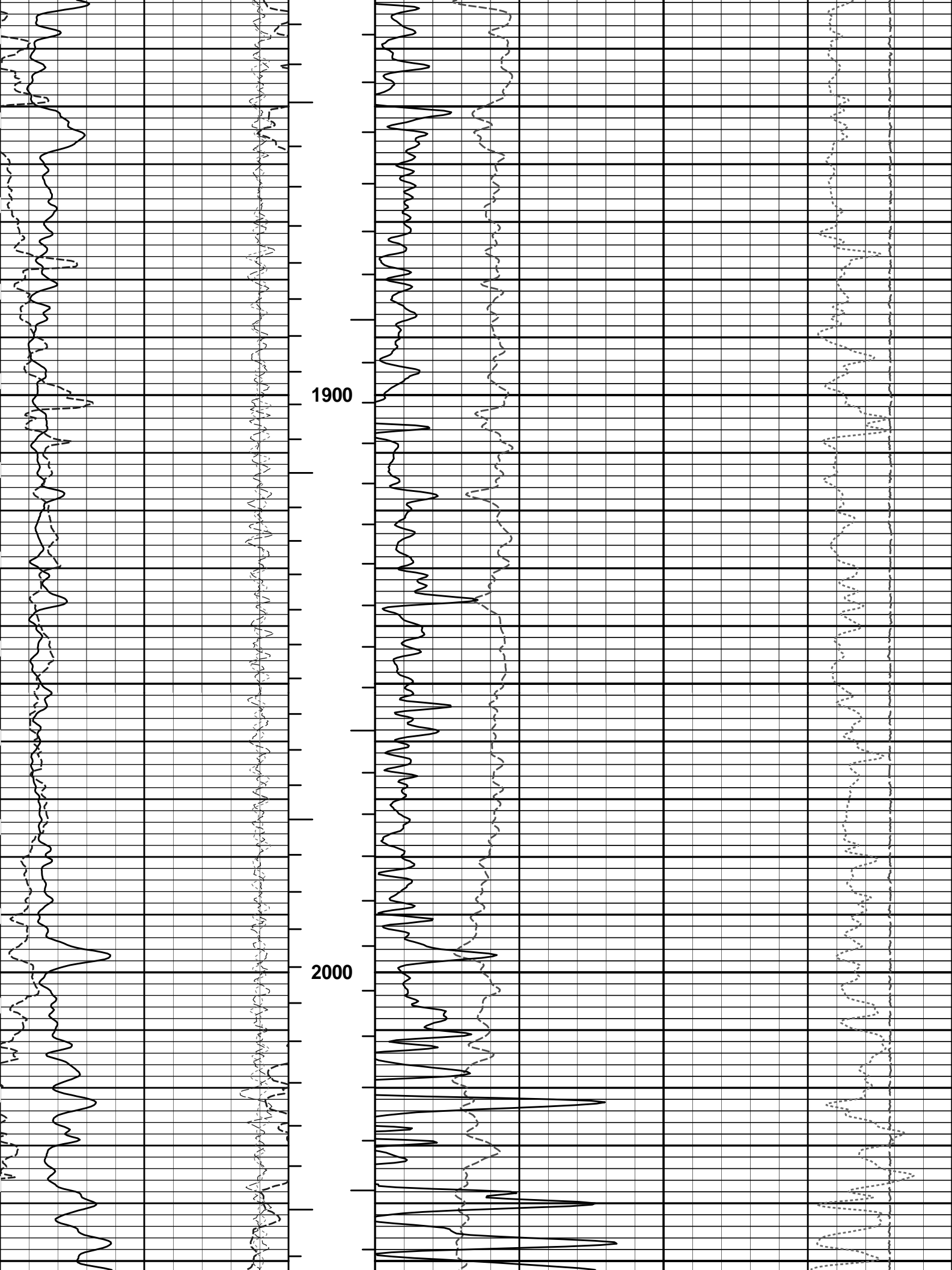

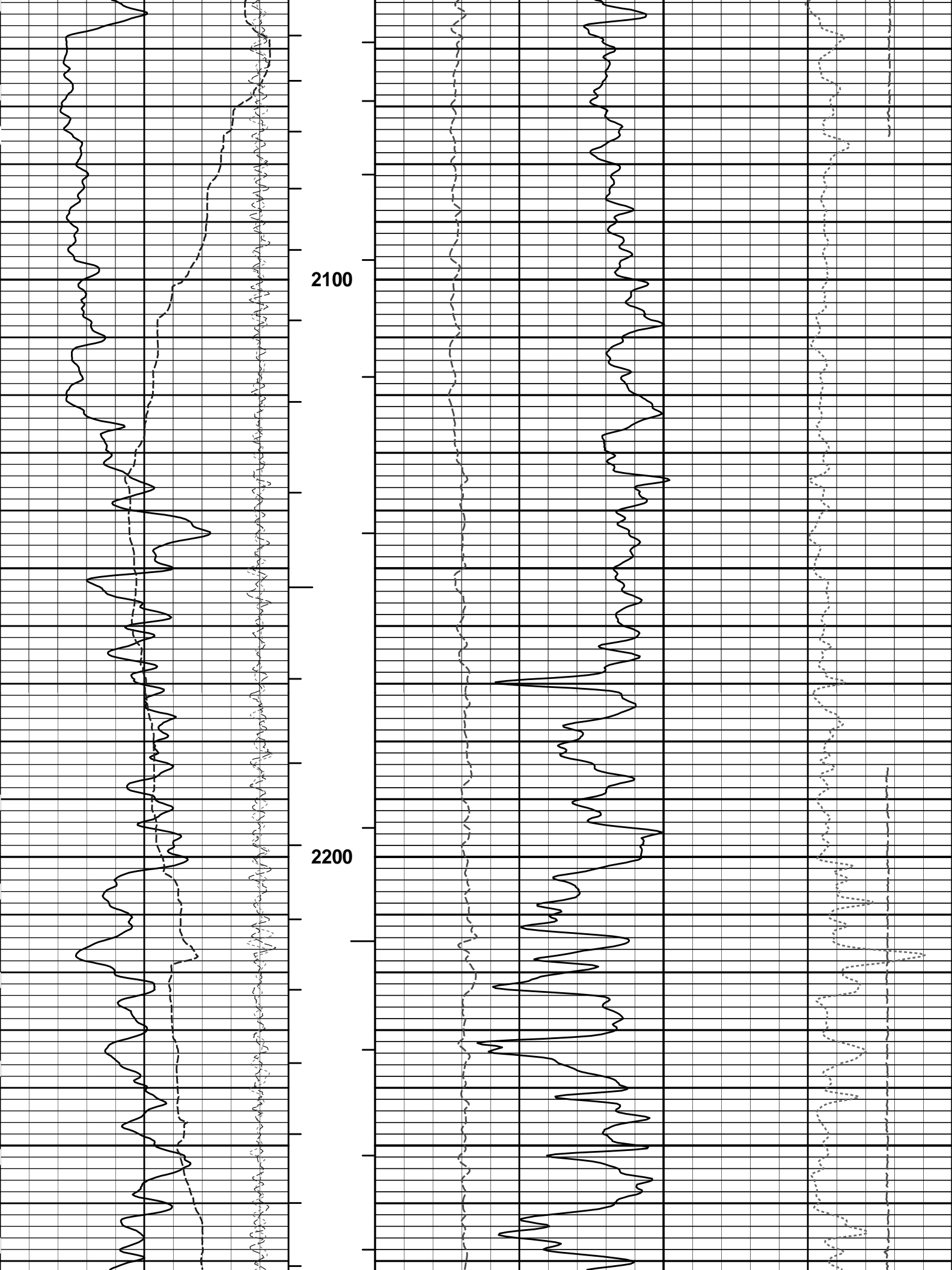

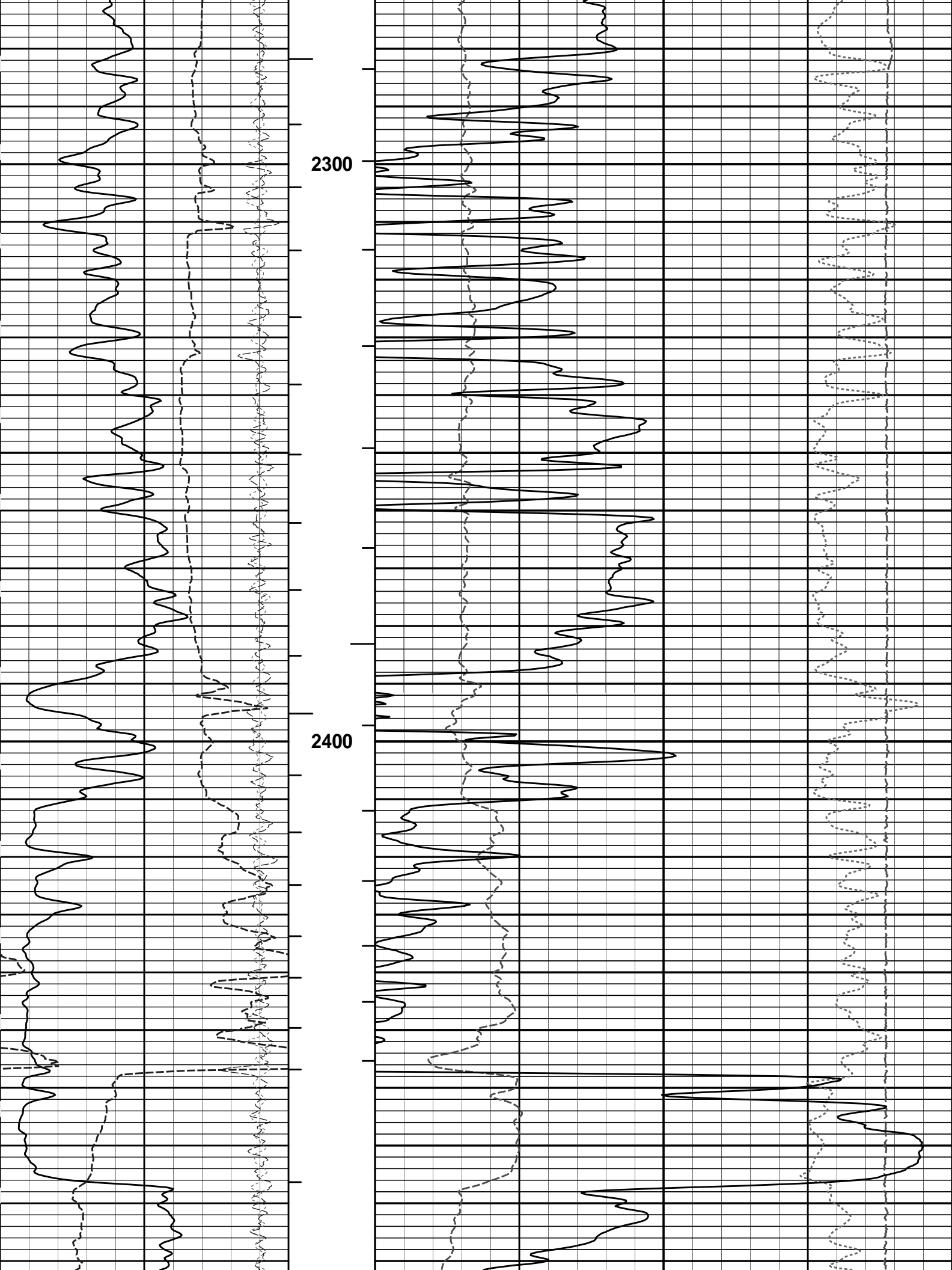

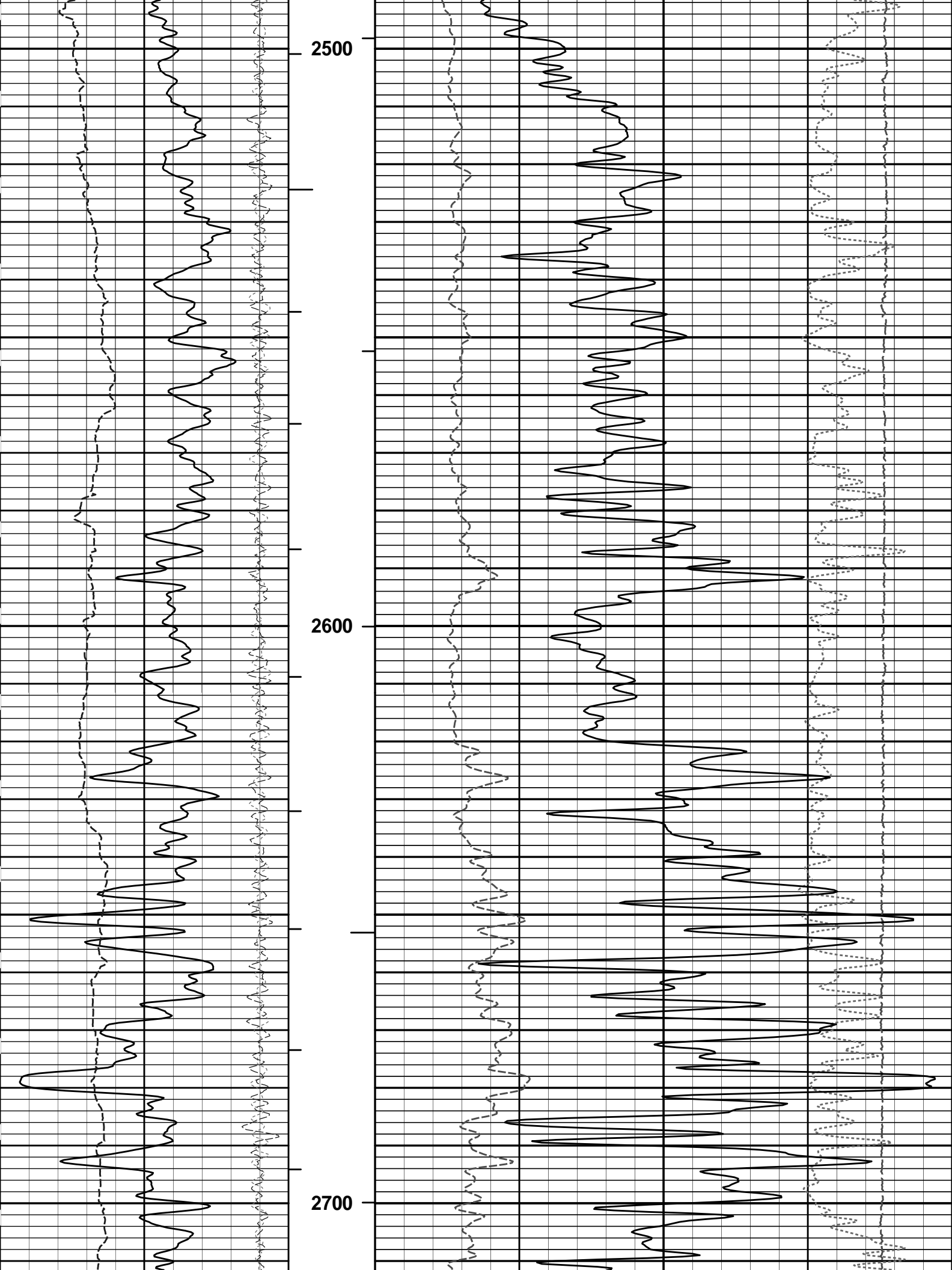

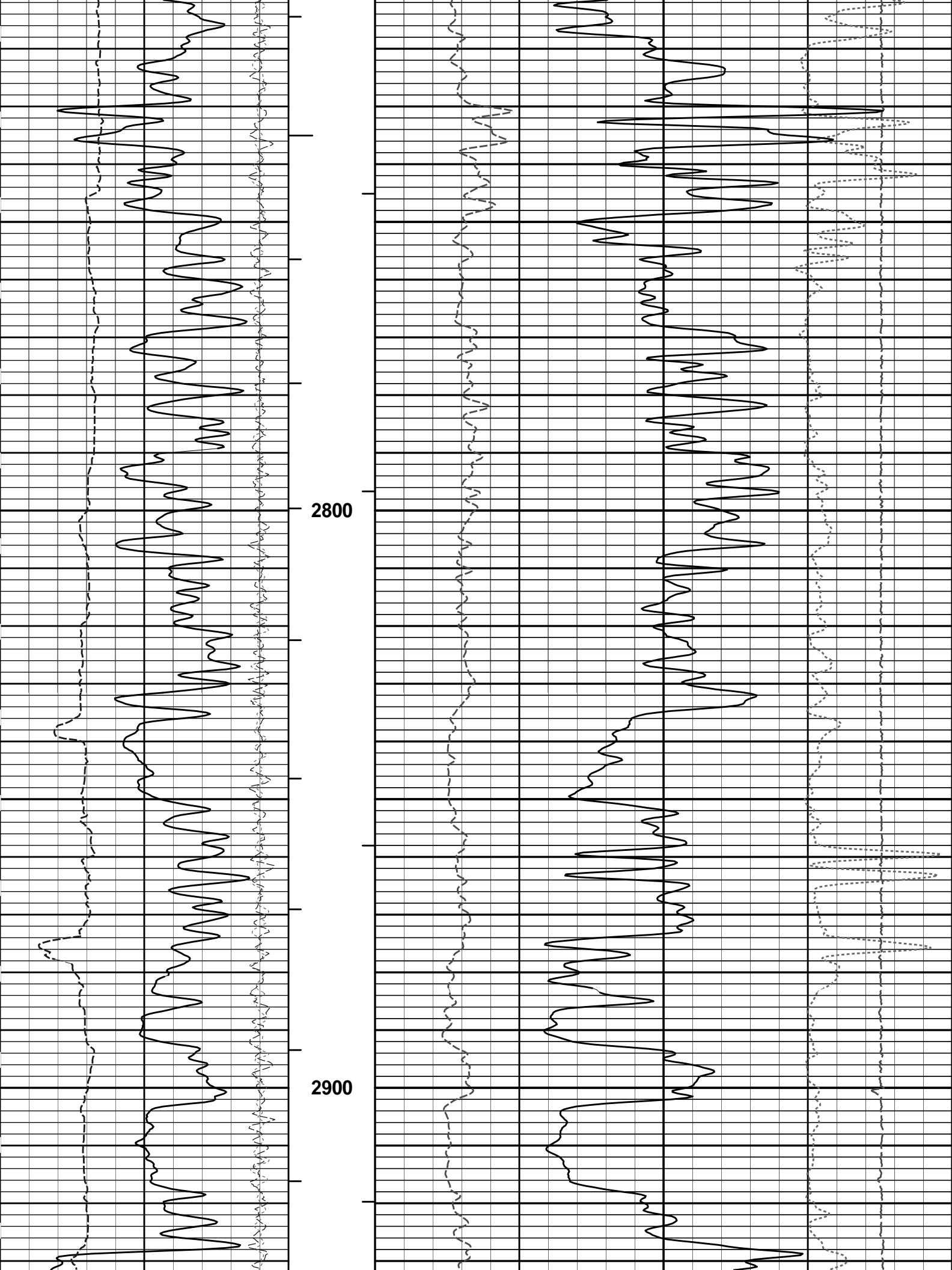

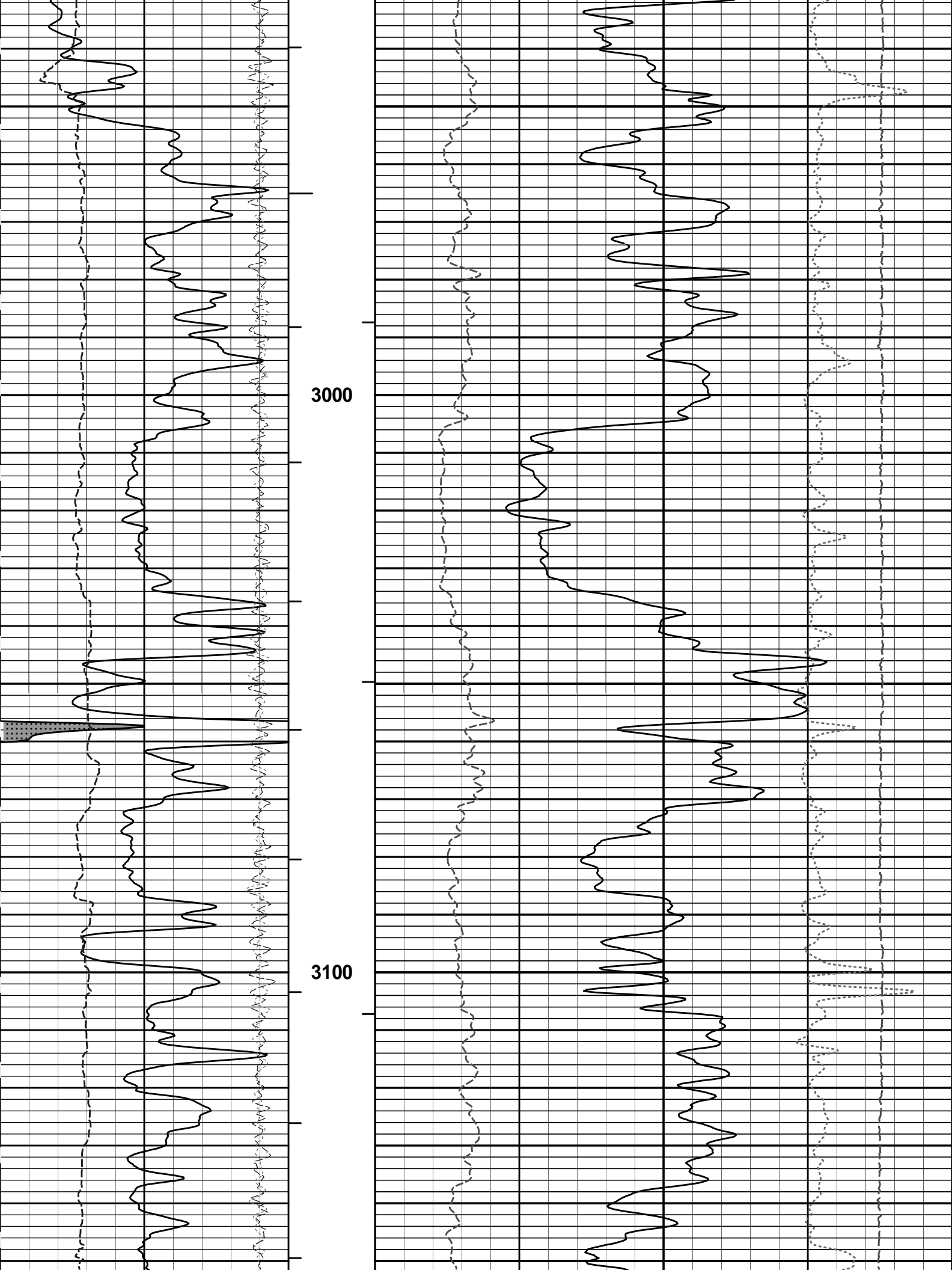

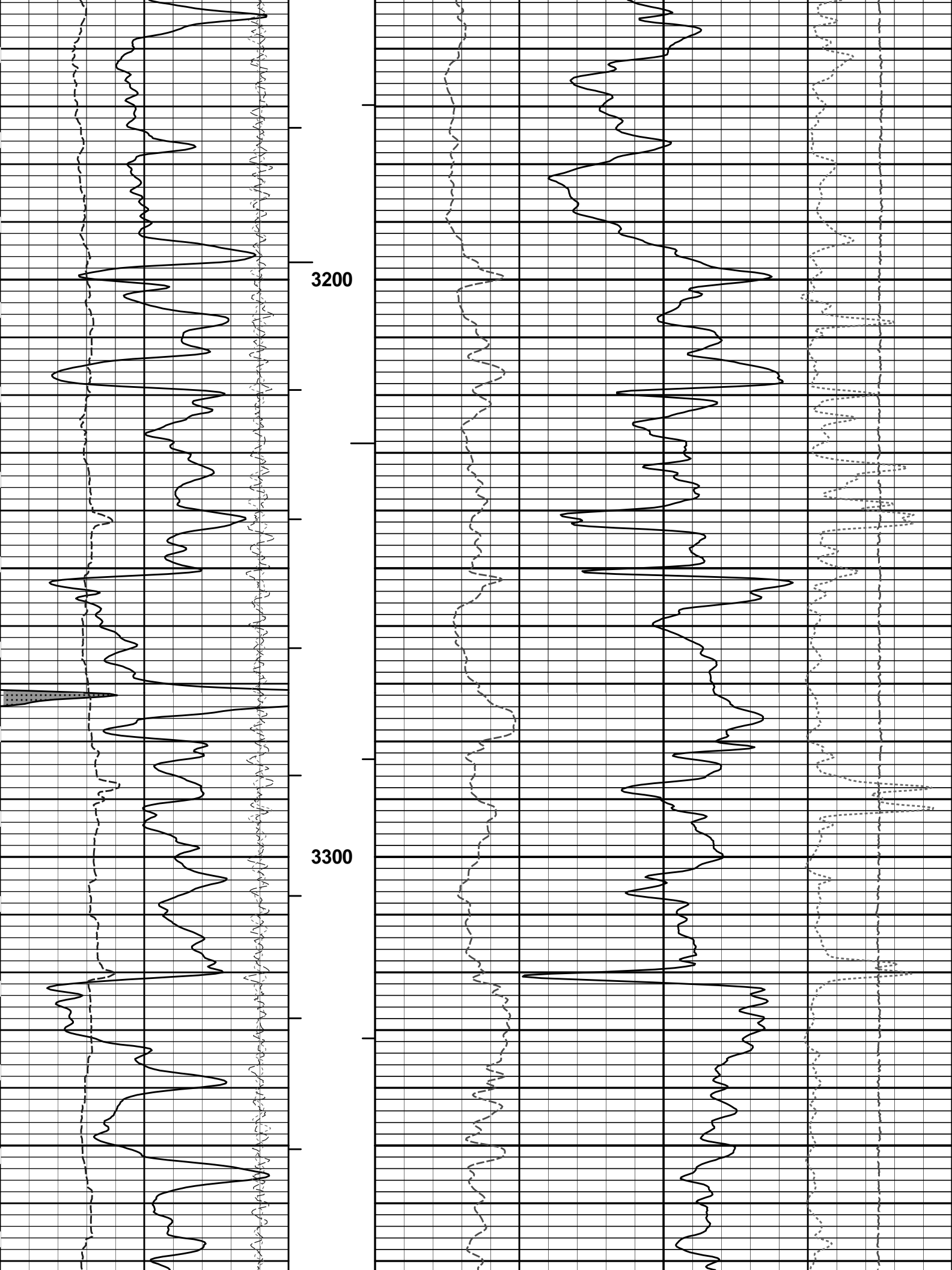

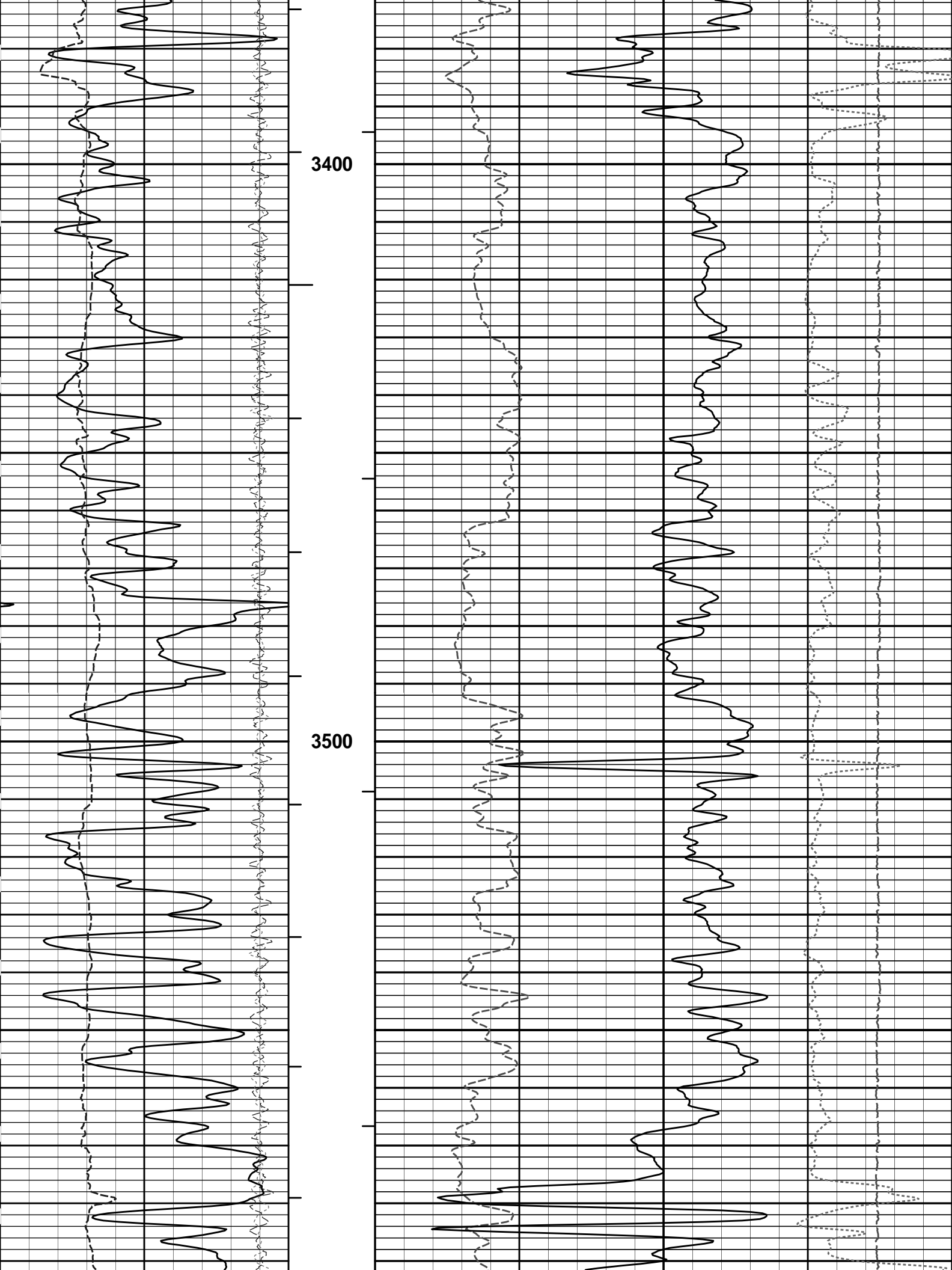

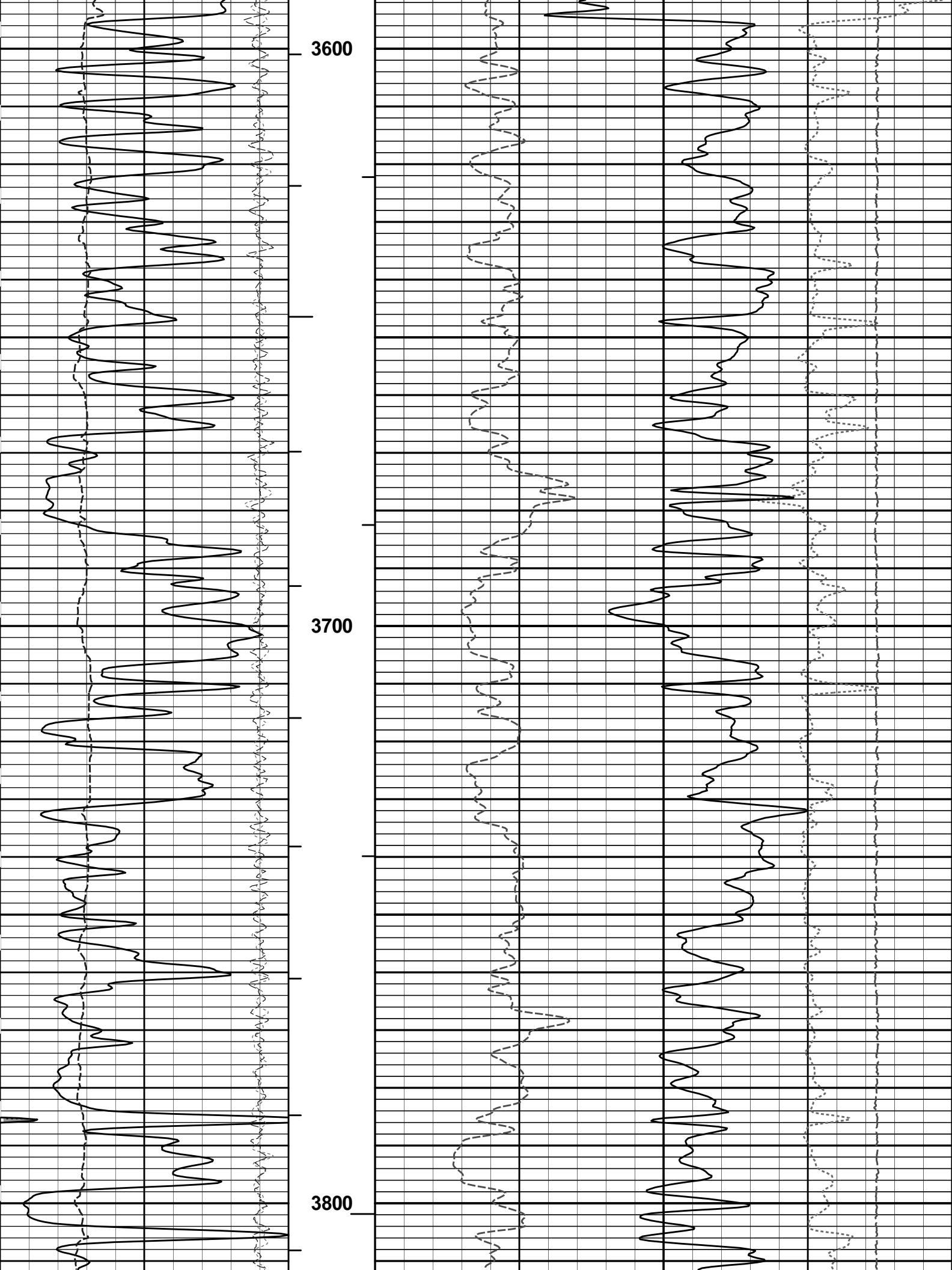

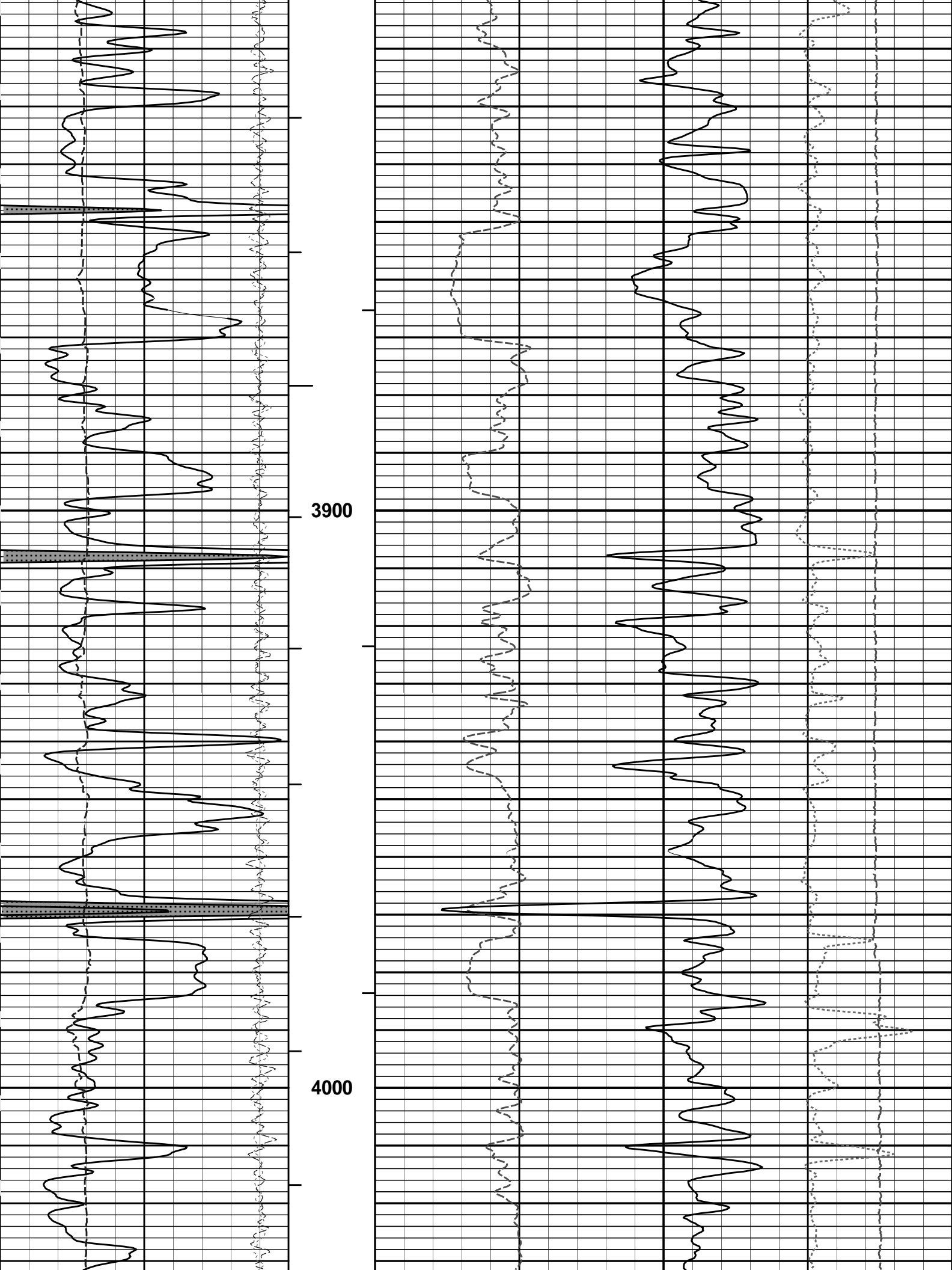

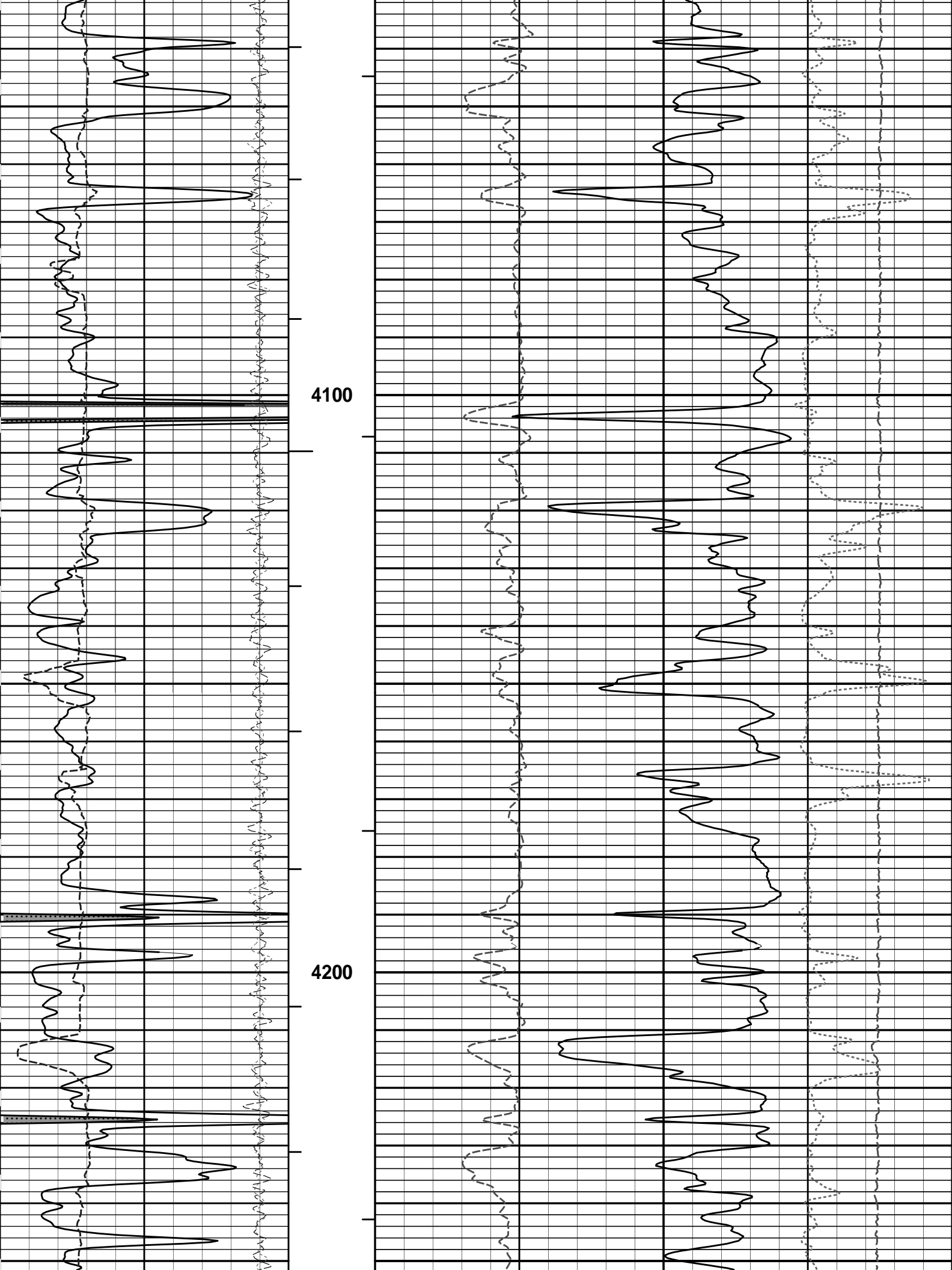

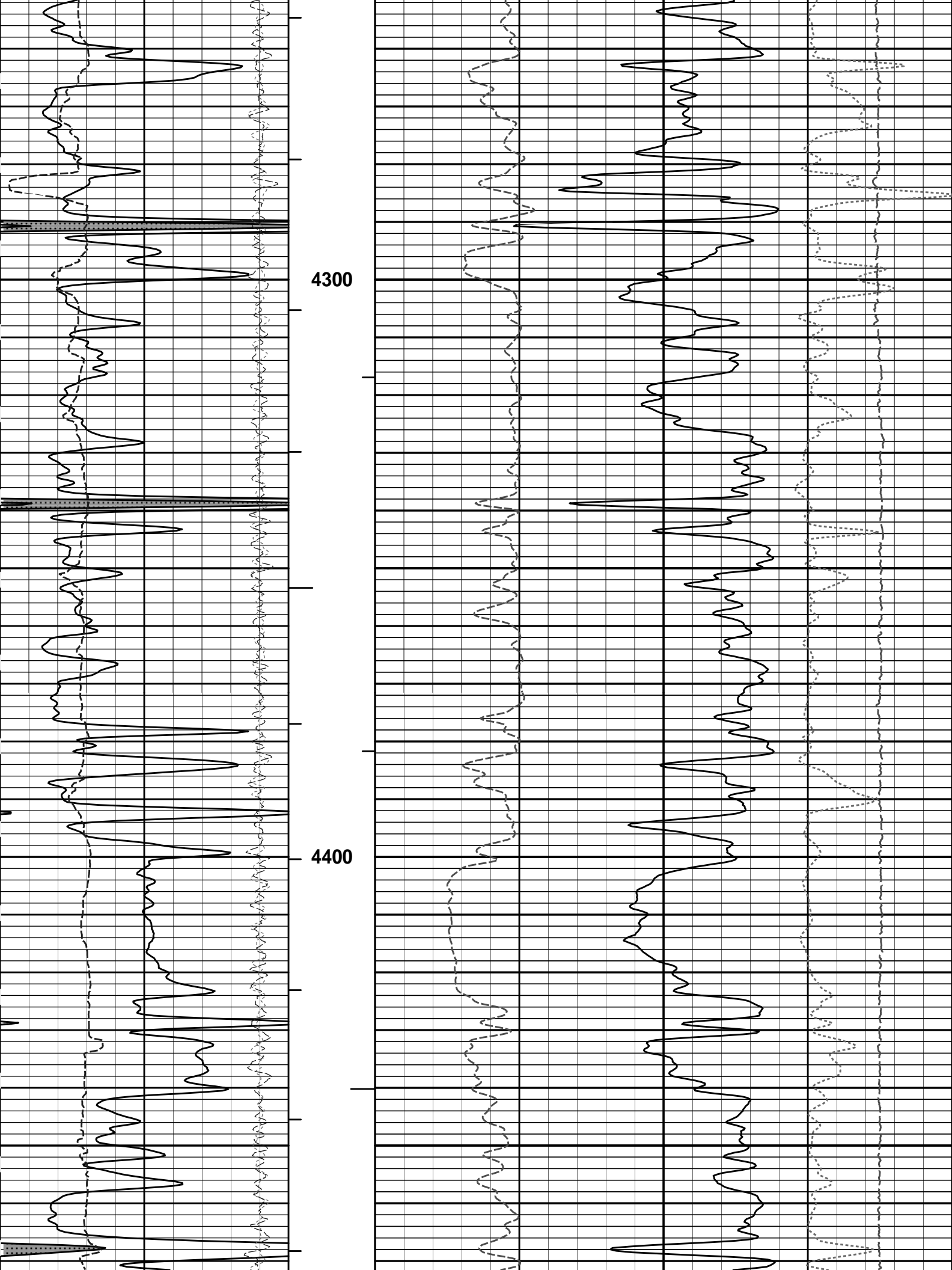

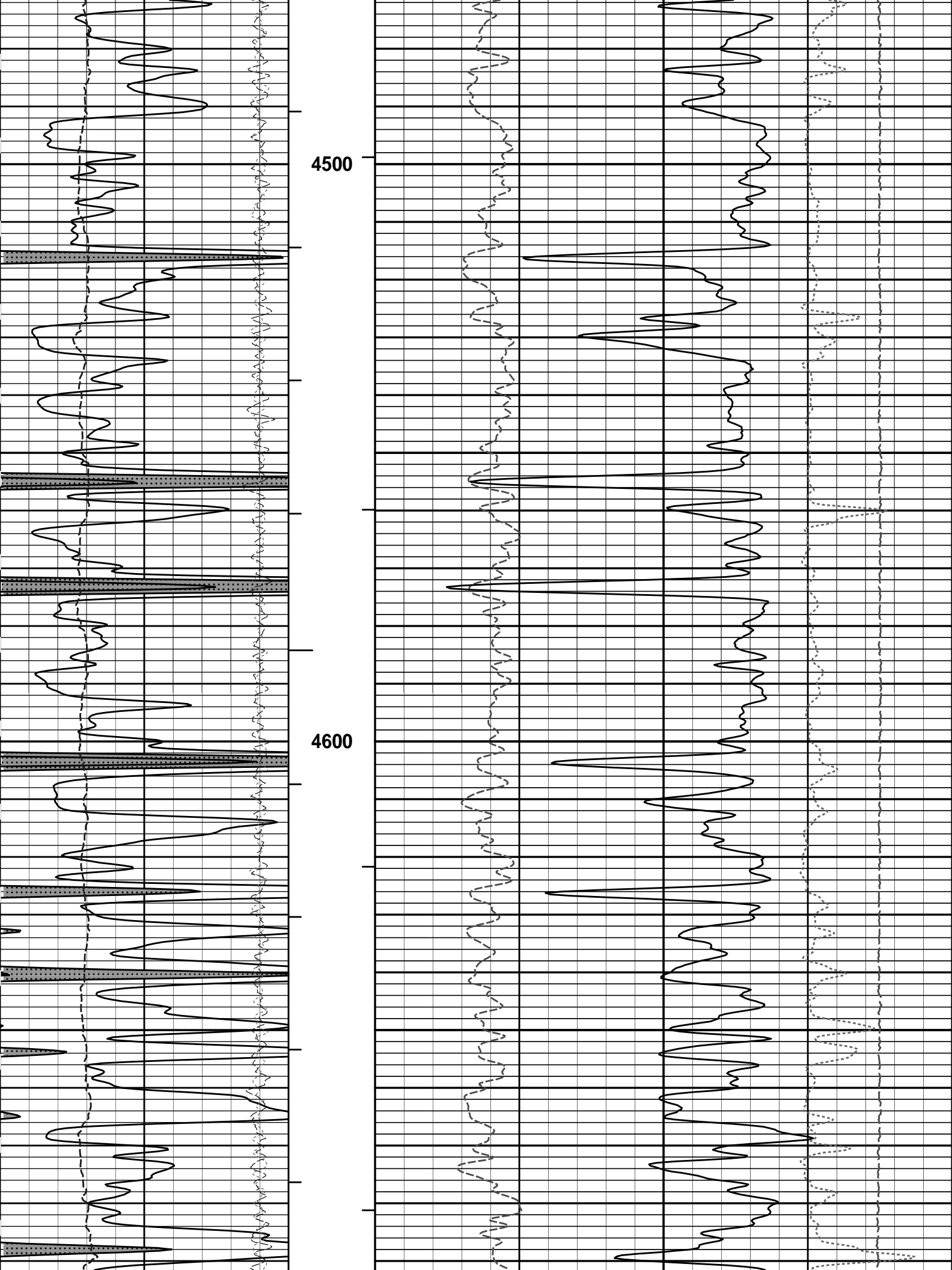

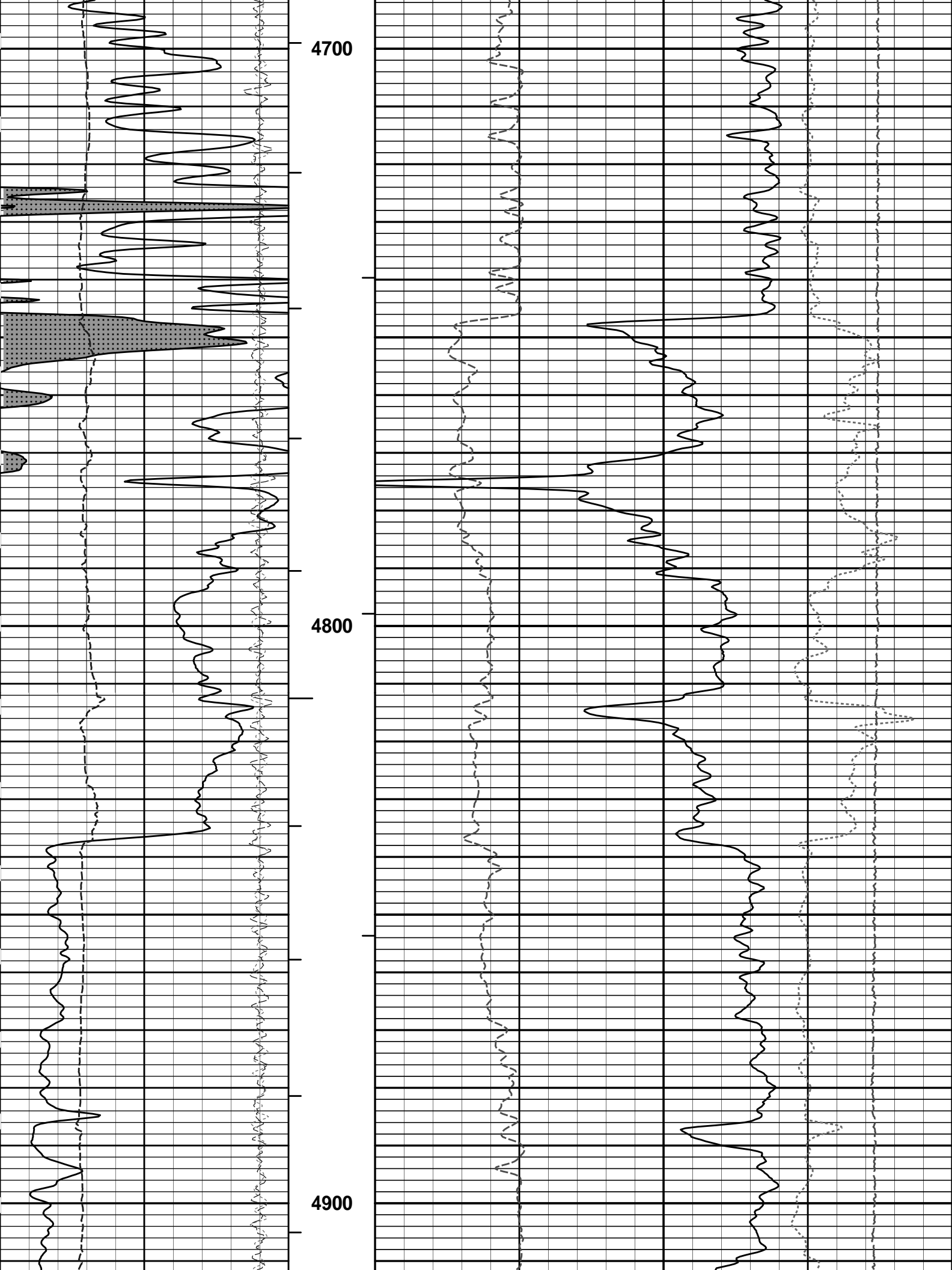

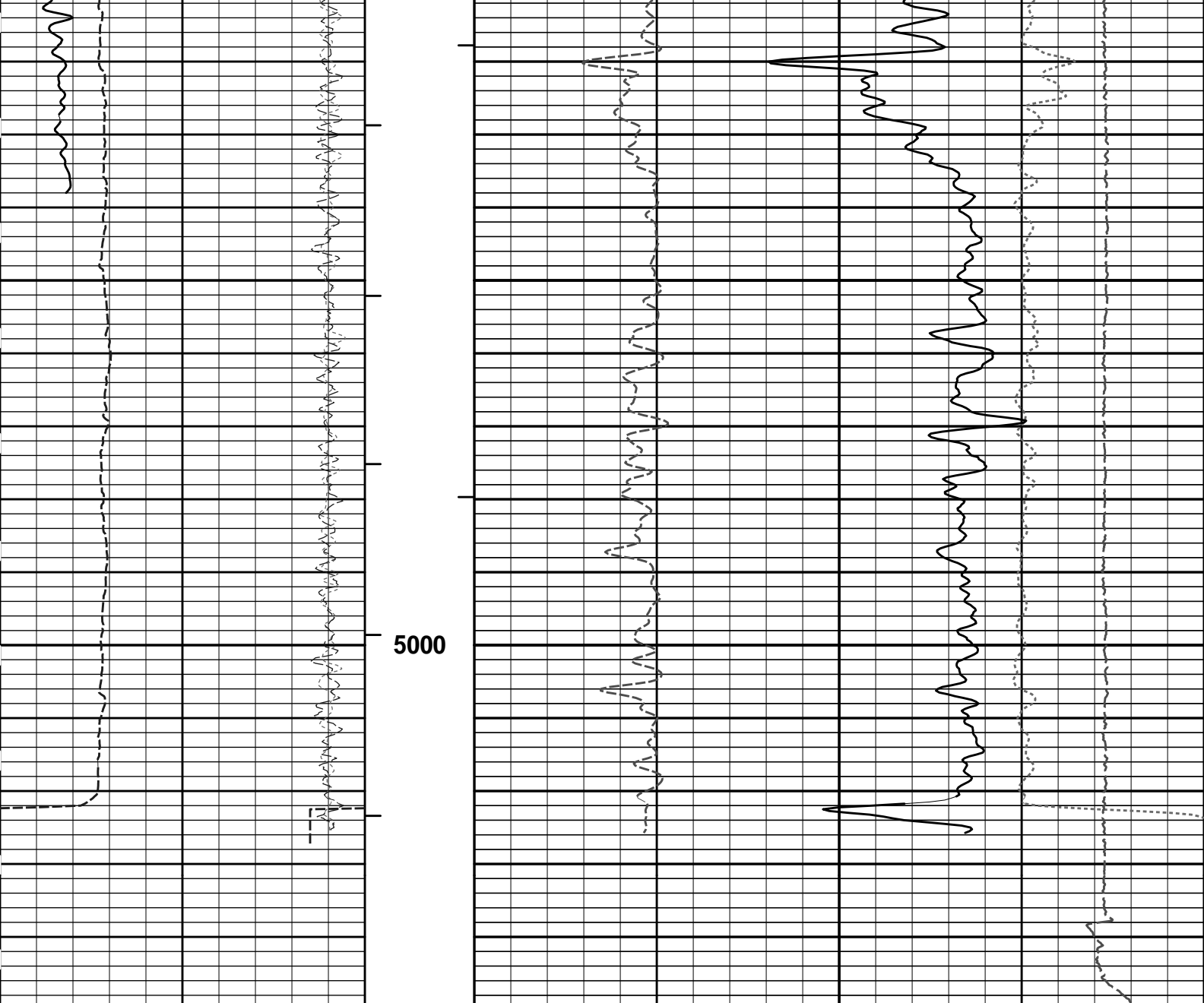

6	Caliper	16	MD	0	Pe	10	-0.25	DensityCorr	0.25
	inches		1 : 240					g/cc	
-18	NearQuality	2	AHV				15K	Tension	0
			ft3					pounds	
18	FarQuality	-2	BHV	2	Bulk Density				3
			ft3		g/cc				
0	Gamma Ray	150							
	api								
	SHALE								

HALLIBURTON

Plot Time: 25-Nov-13 15:44:08
 Plot Range: 1495.75 ft to 5049.75 ft
 Data: SIMONS_1736_112\Well Based\R1 CASING\
 Plot File: \\-LOCAL-SIMONS_1736_112\Well Based\POROSITY\BULKD_5_MAIN_LIB

5 INCH MAIN LOG

REPEAT SECTION

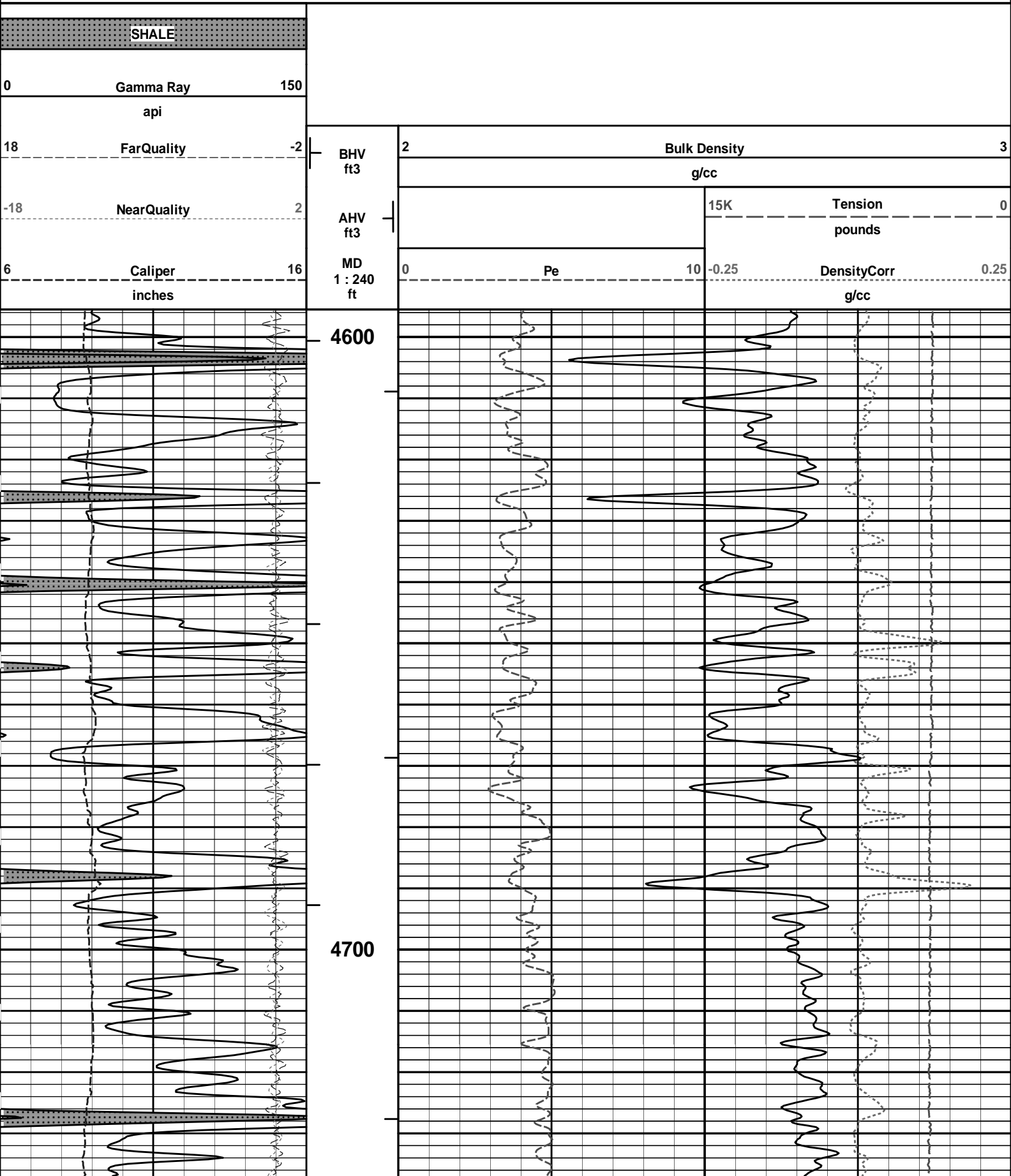

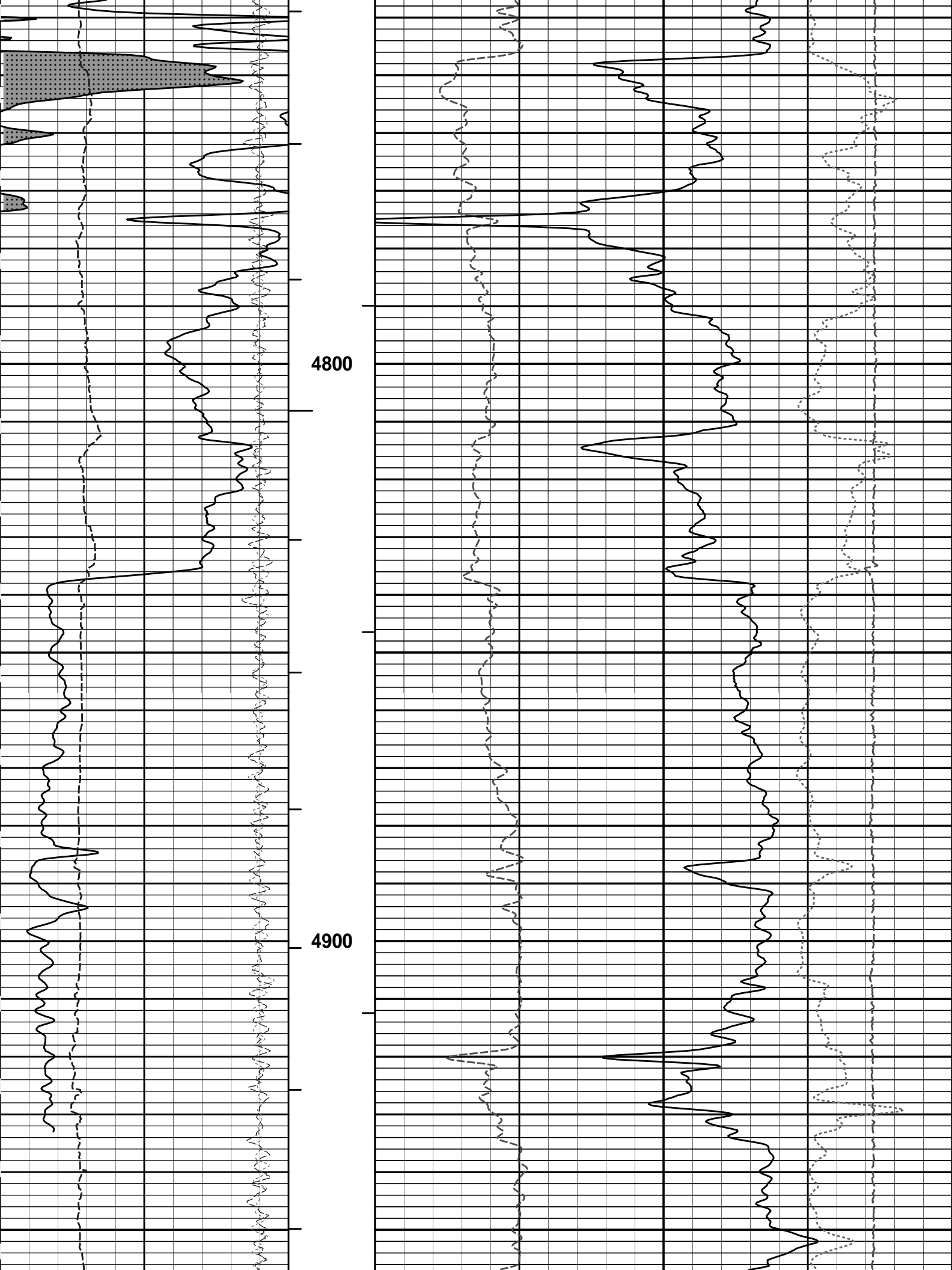

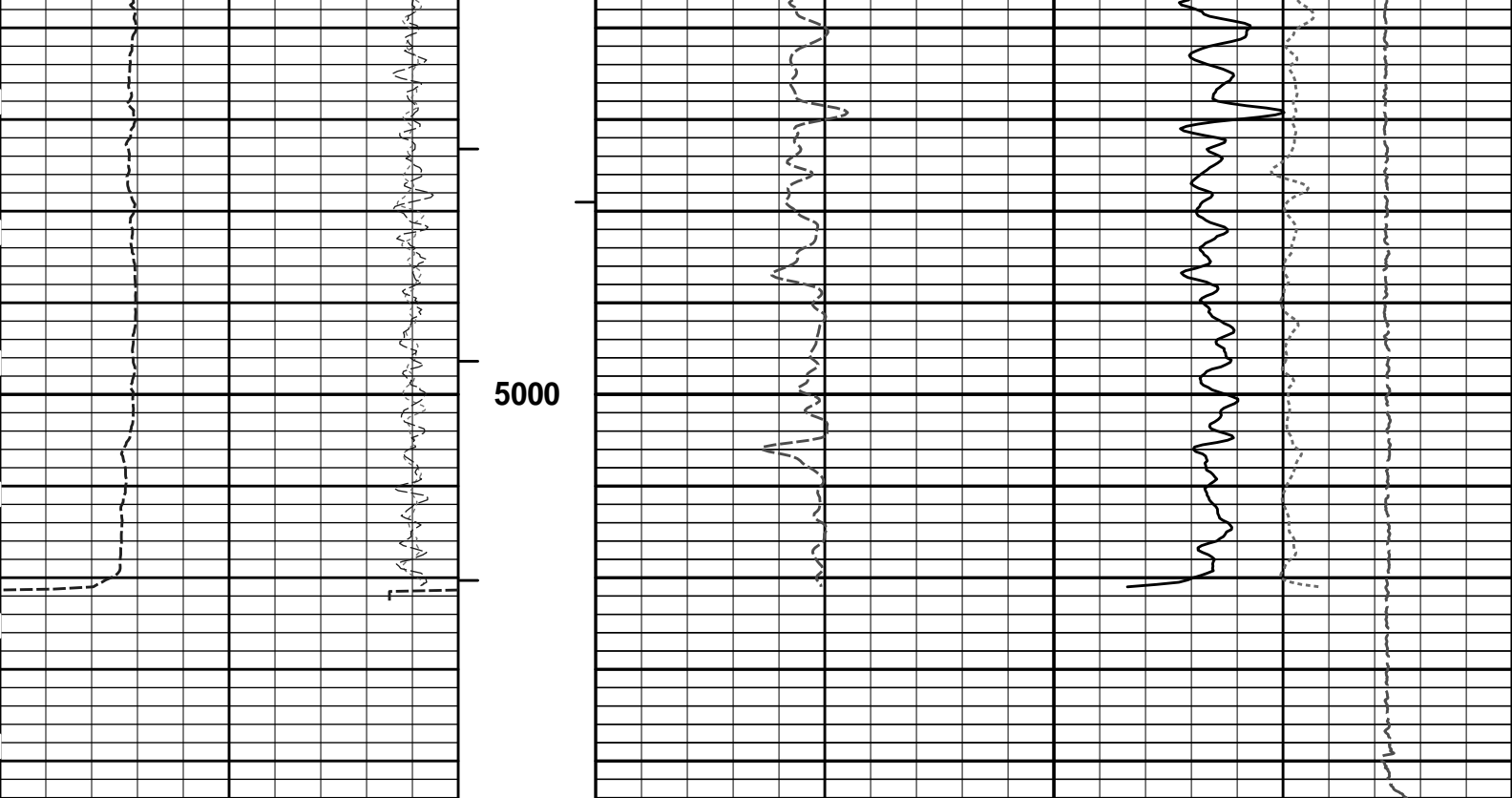

6	Caliper	16	MD	0	Pe	10	-0.25	DensityCorr	0.25
	inches		1 : 240					g/cc	
-18	NearQuality	2	AHV				15K	Tension	0
			ft3					pounds	
18	FarQuality	-2	BHV	2	Bulk Density				3
			ft3		g/cc				
0	Gamma Ray	150							
	api								
	SHALE								

HALLIBURTON

Plot Time: 25-Nov-13 15:44:10
 Plot Range: 4595.5 ft to 5044.67 ft
 Data: SIMONS_1736_112\Well Based\R1 REPEAT\
 Plot File: \\-LOCAL-\SIMONS_1736_112\Well Based\POROSITY\BULKD_5_REP_LIB

REPEAT SECTION

HALLIBURTON

TOOL STRING DIAGRAM REPORT

Description	Overbody Description	O.D.	Diagram	Sensors @ Delays	Length	Accumulated Length
RWCH-12156658 135.00 lbs		Ø 3.625 in		← Load Cell @ 123.47 ft ← BH Temperature @ 122.91 ft	6.25 ft	127.16 ft

SP Sub-11441455
60.00 lbs

Ø 3.625 in →

← SP @ 119.13 ft

3.74 ft

120.91 ft

117.17 ft

GTET-11021139
165.00 lbs

Ø 3.625 in →

← GammaRay @ 111.11 ft

8.52 ft

108.65 ft

CSNG-10965402
114.00 lbs

Ø 3.625 in →

← CSNG @ 103.02 ft

8.17 ft

100.48 ft

ICT-11204020
330.00 lbs

Ø 3.625 in →

← ICT Caliper @ 90.44 ft

12.83 ft

87.65 ft

IDT-10967514
150.00 lbs

Ø 3.625 in →

7.58 ft

80.07 ft

Centralizer 25-002
8.00 lbs

Ø 4.000 in* →

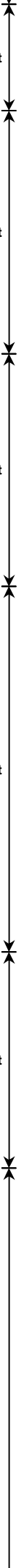
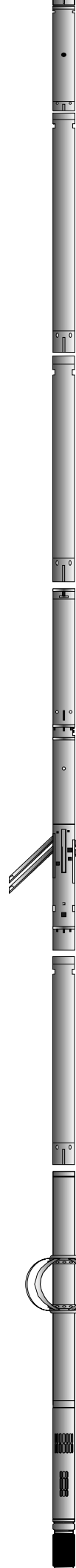
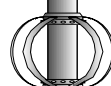

Wavesonic-I-
10753396
520.00 lbs

Ø 3.625 in →

34.07 ft

← Wavesonic Delay @ 57.50 ft

Centralizer 25-001
8.00 lbs

Ø 4.000 in* →



46.00 ft

IQ Flex-0000696
140.00 lbs

Ø 3.625 in →

5.67 ft

40.33 ft

DSN Decentralizer-
10755066
6.60 lbs

Ø 5.000 in* →

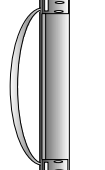

Ø 3.625 in →

9.69 ft

DSNT-11055304
174.00 lbs

← DSN Far @ 33.39 ft
← DSN Near @ 32.64 ft

30.64 ft

SDLT-11014296
360.00 lbs

SDLT Pad-10865884
65.00 lbs
Microlog Pad-11014296
8.00 lbs

Ø 4.500 in →

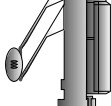

Ø 4.750 in* →

Ø 4.750 in* →

10.81 ft

← Microlog @ 22.83 ft
← SDL Caliper @ 22.65 ft
← SDL @ 22.64 ft

19.83 ft

ACRt Instrument-
11022962
50.00 lbs

Ø 3.625 in →

5.03 ft

14.80 ft

Regal Standoff 6_75-
0000058
20.00 lbs

Ø 6.750 in* →

← Mud Resistivity @ 13.44 ft

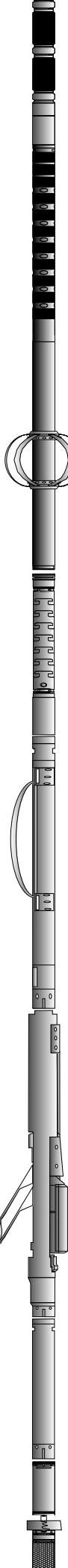

ACRt Sonde-
11005909
200.00 lbs

Ø 3.625 in →

← ACRt @ 9.46 ft

14.22 ft

Cabbage Head-
00000030
10.00 lbs

Ø 3.625 in ↘
Ø 6.000 in →

0.58 ft
0.58 ft
0.00 ft

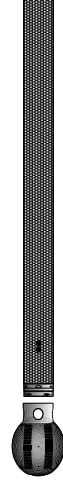

Mnemonic	Tool Name	Serial Number	Weight (lbs)	Length (ft)	Accumulated Length (ft)	Max.Log. Speed (fpm)
RWCH	Releasable Wireline Cable Head	12156658	135.00	6.25	120.91	300.00
SP	SP Sub	11441455	60.00	3.74	117.17	300.00
GTET	Gamma Telemetry Tool	11021139	165.00	8.52	108.65	60.00
CSNG	Compensated Spectral Natural Gamma	10965402	114.00	8.17	100.48	15.00
ICT	Six Independent Arm Caliper	11204020	330.00	12.83	87.65	30.00
IDT	Insite Directional Tool	10967514	150.00	7.58	80.07	30.00
WSTT	WaveSonic Insite	10753396	520.00	34.07	46.00	30.00
OBCEN	Centralizer - 25 in. Overbody	001	8.00	2.08 *	48.85	300.00
OBCEN	Centralizer - 25 in. Overbody	002	8.00	2.08 *	74.99	300.00
IQF	IQ Flex tool	00000696	140.00	5.67	40.33	300.00
DSNT	Dual Spaced Neutron	11055304	174.00	9.69	30.64	60.00
DCNT	DSN Decentralizer	10755066	6.60	5.13 *	33.97	300.00
SDLT	Spectral Density Tool	11014296	360.00	10.81	19.83	60.00
SDLP	Density Insite Pad	10865884	65.00	2.55 *	22.04	60.00
MICP	Microlog Pad	11014296	8.00	1.00 *	22.33	60.00
ACRt	Array Compensated True Resistivity Instrument Section	11022962	50.00	5.03	14.80	300.00
ACRt	Array Compensated True Resistivity Sonde Section	11005909	200.00	14.22	0.58	300.00
RSOF	Regal Standoff 6.75in	00000058	20.00	0.52 *	12.45	300.00
CBHD	Cabbage Head	00000030	10.00	0.58	0.00	300.00

Total **2,523.60** **127.16**

* Not included in Total Length and Length Accumulation.

Data: SIMONS_1736_1120001 SP-GTET-CSNG-ICT-IDT-WAVE-FLEX-DSN-SDL-ACRT-CH006 25-Nov-13 09:21 Up @5050.3f Date: 25-Nov-13 12:46:09

HALLIBURTON

PARAMETERS REPORT

Depth (ft)	Tool Name	Mnemonic	Description	Value	Units
TOP					
	SHARED	BS	Bit Size	8.750	in
	SHARED	UBS	Use Bit Size instead of Caliper for all applications.	No	
	SHARED	MDBS	Mud Base	Water	
	SHARED	MDWT	Borehole Fluid Weight	9.300	ppg
	SHARED	WAGT	Weighting Agent	Natural	
	SHARED	BSAL	Borehole salinity	0.00	ppm
	SHARED	FSAL	Formation Salinity NaCl	0.00	ppm
	SHARED	KPCT	Percent K in Mud by Weight?	0.00	%
	SHARED	RMUD	Mud Resistivity	0.500	ohmm
	SHARED	TRM	Temperature of Mud	75.0	degF
	SHARED	CSD	Logging Interval is Cased?	No	

SHARED	ICOD	AHV Casing OD	7.000	in
SHARED	ST	Surface Temperature	75.0	degF
SHARED	TD	Total Well Depth	5050.00	ft
SHARED	BHT	Bottom Hole Temperature	135.0	degF
SHARED	SVTM	Navigation and Survey Master Tool	IDT	
SHARED	AZTM	High Res Z Accelerometer Master Tool	IDT	
SHARED	TEMM	Temperature Master Tool	NONE	
SHARED	BHSM	Borehole Size Master Tool	ICT	
Rwa / CrossPlot	XPOK	Process Crossplot?	Yes	
Rwa / CrossPlot	FCHO	Select Source of F	Automatic	
Rwa / CrossPlot	AFAC	Archie A factor	0.6200	
Rwa / CrossPlot	MFAC	Archie M factor	2.1500	
Rwa / CrossPlot	RMFR	Rmf Reference	0.10	ohmm
Rwa / CrossPlot	TMFR	Rmf Ref Temp	75.00	degF
Rwa / CrossPlot	RWA	Resistivity of Formation Water	0.05	ohmm
Rwa / CrossPlot	ADP	Use Air Porosity to calculate CrossplotPhi	No	
GTET	GROK	Process Gamma Ray?	Yes	
GTET	GRSO	Gamma Tool Standoff	0.000	in
GTET	GEOK	Process Gamma Ray EVR?	No	
GTET	TPOS	Tool Position for Gamma Ray Tools.	Eccentered	
CSNG	CGOK	Process CSNG Data?	Yes	
CSNG	CENT	Is Tool Centralized?	No	
CSNG	GBOK	Gamma Enviromental Corrections?	Yes	
CSNG	BARF	Barite Correction Factor	1.00	
CSNG	ORDG	Use Fixed Gain	No	
CSNG	ORDO	Use Fixed Offset	No	
CSNG	ORDR	Use Fixed Resolution Degradation Factor	No	
ICT	CLOK	Process Caliper Outputs?	Yes	
ICT	DARM	Disable Caliper Arm	No	
ICT	ATDS	Arm To Disable	0	
ICT	REPM	Method to replace arm?	Caliper Average	
ICT	ARMV	Diameter to use for disabled arm	0.00	in
ICT	DARM	Disable Second Caliper Arm	No	
ICT	ATDS	Second Arm To Disable	0	
ICT	REPM	Method to replace second arm?	Caliper Average	
ICT	ARMV	Diameter to use for second disabled arm	0.00	in
ICT	NAVS	Navigation Source Tool	IDT	
ICT	CL10	Radius 1 Offset	0.0	in
ICT	CL20	Radius 2 Offset	0.0	in
ICT	CL30	Radius 3 Offset	0.0	in
ICT	CL40	Radius 4 Offset	0.0	in
ICT	CL50	Radius 5 Offset	0.0	in
ICT	CL60	Radius 6 Offset	0.0	in
ICT	BHVC	Radius type for borehole volume calcuations	Elliptical	
IDT	WRTI	Survey Writing Interval	30	ft
IDT	SOPT	Smoothing Option	None	
Wavesonic-I	WSOK	Process WSTT?	Yes	
Wavesonic-I	AFIL	Adaptive Filtering?	No	
Wavesonic-I	PINT	Process 1 Sample and Skip	0	
Wavesonic-I	PROM	Process Mode: M=1,MX=2,MY=3,MXY=4	4	
Wavesonic-I	DTSH	Delta -T Shale	100.00	uspf

Wavesonic-I	DTMT	Delta -T Matrix Type	User define	
Wavesonic-I	DTMA	Delta -T Matrix	47.60	uspf
Wavesonic-I	DTFL	Delta -T Fluid	189.00	uspf
Wavesonic-I	RHOM	Matrix Density	2.7100	g/cc
Wavesonic-I	RHOF	Fluid Density	1.0000	g/cc
Wavesonic-I	SMTH	Semblance Threshold	0.25	
Wavesonic-I	VPVS	VPVS Ratio for Porosity	1.40	
Wavesonic-I	APEQ	Acoustic Porosity Equation	Wylie	
Wavesonic-I	NAVS	Navigation Source Tool	IDT	
DSNT	DNOK	Process DSN?	Yes	
DSNT	DEOK	Process DSN EVR?	No	
DSNT	NLIT	Neutron Lithology	Limestone	
DSNT	DNSO	DSN Standoff - 0.25 in (6.35 mm) Recommended	0.250	in
DSNT	DNTP	Temperature Correction Type	None	
DSNT	DPRS	DSN Pressure Correction Type	None	
DSNT	SHCO	View More Correction Options	No	
DSNT	UTVD	Use TVD for Gradient Corrections?	No	
DSNT	LHWT	Logging Horizontal Water Tank?	No	
SDLT	CLOK	Process Caliper Outputs?	Yes	
SDLT Pad	DNOK	Process Density?	Yes	
SDLT Pad	DNOK	Process Density EVR?	No	
SDLT Pad	CB	Logging Calibration Blocks?	No	
SDLT Pad	SPVT	SDLT Pad Temperature Valid?	Yes	
SDLT Pad	DTWN	Disable temperature warning	No	
SDLT Pad	DMA	Formation Density Matrix	2.710	g/cc
SDLT Pad	DFL	Formation Density Fluid	1.000	g/cc
Microlog Pad	MLOK	Process MicroLog Outputs?	Yes	
ACRt Sonde	RTOK	Process ACRt?	Yes	
ACRt Sonde	MNSO	Minimum Tool Standoff	1.50	in
ACRt Sonde	TCS1	Temperature Correction Source	FP Lwr & FP Upr	
ACRt Sonde	TPOS	Tool Position	Free Hanging	
ACRt Sonde	RMOP	Rmud Source	Mud Cell	
ACRt Sonde	RMIN	Minimum Resistivity for MAP	0.20	ohmm
ACRt Sonde	RMIN	Maximum Resistivity for MAP	200.00	ohmm
ACRt Sonde	THQY	Threshold Quality	0.50	
ACRt Sonde	MRFX	Fixed mud resistivity	2000	ohmm

BOTTOM

Data: SIMONS_1736_112\0001 SP-GTET-CSNG-ICT-IDT-WAVE-FLEX-DSN-SDL-ACRT-CH\006 25-Nov-13 09:21 Up @5050.3f

Date: 25-Nov-13 12:45:41

HALLIBURTON

CALIBRATION REPORT

NATURAL GAMMA RAY TOOL SHOP CALIBRATION

Tool Name: GTET - 11021139

Reference Calibration Date: 01-Jan-70 00:00:00

Engineer: SHELDON INGERSOLL

Calibration Date: 16-Nov-13 17:40:06

Software Version: WL INSITE R3.8.4 (Build 5)

Calibration Version: 1

Calibrator Source S/N: TB146

Calibrator API Reference:265.00 api

Equivalent Calibrator API Reference:269.6 api

Measurement	Measured	Calibrated	Units
Background	47.8	47.8	api
Background + Calibrator	317.5	317.5	api

NATURAL GAMMA RAY TOOL FIELD CALIBRATION**Tool Name:** GTET - 11021139**Reference Calibration Date:** 16-Nov-13 17:40:06**Engineer:** SHELDON INGERSOLL**Calibration Date:** 24-Nov-13 21:38:26**Software Version:** WL INSITE R3.8.4 (Build 5)**Calibration Version:** 1

Calibrator Source S/N: TB146

Calibrator API Reference:265.00 api

Equivalent Calibrator API Reference:269.6 api

Field Verification	Shop	Field	Units
Background	47.8	94.1	api
Background + Calibrator	317.5	372.2	api
Calibrator	269.6	278.1	api
Shop	Field	Difference	Tolerance
269.6	278.1	-8.5	+/- 9.00

DUAL SPACED NEUTRON SHOP CALIBRATION**Tool Name:** DSNT - 11055304**Reference Calibration Date:** 19-Nov-13 15:04:23**Engineer:** SHELDON INGERSOLL**Calibration Date:** 19-Nov-13 15:17:39**Software Version:** WL INSITE R3.8.4 (Build 5)**Calibration Version:** 1

Logging Source S/N: 696

Tank Serial Number: LIBERAL_NEUTRON

Reference value assigned to Tank: 51.680

Snow Block S/N: 696

Calibration Tank Water Temperature: 68 degF

Min. Tool Housing Outside Diameter: 3.625 in

CALIBRATION CONSTANTS

Measurement	Prev. Value	New Value	Control Limit On New Value
Gain:	0.987	0.989	0.900 - 1.100

WATER TANK SUMMARY (Horizontal Water Tank)

Measurement	Current Reading (Previous Coef.)	Calibrated (New Coef.)	Change	Control Limit On Change
Porosity (decp):	0.2105	0.2110	0.0005	+/- 0.0020
Calibrated Ratio:	9.71	9.73	0.017	+/- 0.050

VERIFIER

Measurement	Value	Control Limit
Snow-Block Porosity (decp):	0.0675	0.02000 - 0.09000

PASS/FAIL SUMMARY

Background Check:	Passed
Gain-Range Check:	Passed
Snow-Block Check:	Passed

DUAL SPACED NEUTRON FIELD CALIBRATION**Tool Name:** DSNT - 11055304**Reference Calibration Date:** 19-Nov-13 15:17:39**Engineer:** SHELDON INGERSOLL**Calibration Date:** 24-Nov-13 21:29:01**Software Version:** WL INSITE R3.8.4 (Build 5)**Calibration Version:** 1

NEUTRON FIELD-CHECK SUMMARY

	Shop	Field	Difference	Control Limit On Change
Snow-Block Porosity (decp):	0.0675	0.0569	-0.0106	+/- 0.0150

PASS/FAIL SUMMARY

Block Change Check:	Passed
Snow Block Stat Check:	Passed
Temperature Check:	Passed

DENSITY CALIPER SHOP CALIBRATION

Tool Name:	SDLT - 11014296	Reference Calibration Date:	19-Sep-13 09:10:42
Engineer:	SHELDON INGERSOLL	Calibration Date:	19-Nov-13 13:55:03
Software Version:	WL INSITE R3.8.4 (Build 5)	Calibration Version:	1
Host Tool Name:	DSNT - 11055304		

CALIBRATION COEFFICIENTS

Measurement	Previous Value	New Value	Control Limit On New Value
Pad Offset	-4038.27	-4114.71	-7000.00 - -1000.00
Pad Gain	0.0003784	0.0003832	0.000200 - 0.000600
Arm Offset	-2841.83	-2593.84	-5000.00 - 3000.00
Arm Gain	0.0005152	0.0005041	0.000300 - 0.000700
Arm Power	-0.000004712	-0.000004571	-0.000010000 - 0.000010000

The ring diameter is computed from: $DIAMETER = PAD\ EXTENSION + ARM\ EXTENSION + TOOL\ DIAMETER$

Tool Diameter: 4.50 in

CALIBRATION RINGS

Measurement	Current Reading (Previous Coeff.)	Calibrated (New Coeff.)	Change	Control Limit On New Value
PAD EXTENSION:				
Small Ring (in)	2.00	2.00	0.00	+/- 0.20
Medium Ring (in)	3.73	3.75	0.02	+/- 0.20
RING DIAMETER:				
Small Ring (in)	6.45	6.50	0.05	+/- 0.20
Medium Ring (in)	8.24	8.25	0.01	+/- 0.20
Large Ring (in)	15.12	15.00	-0.12	+/- 0.20

PASS/FAIL SUMMARY

Calibration-Coefficients Range Check:	Passed
Ring-Measurement Check:	Passed

PASS/FAIL SUMMARY

Calibration-Coefficients Range Check:	Passed
---------------------------------------	--------

SDLT CALIPER FIELD CALIBRATION

Tool Name:	SDLT - 11014296	Reference Calibration Date:	19-Nov-13 13:55:03
Engineer:	SHELDON INGERSOLL	Calibration Date:	24-Nov-13 20:54:18
Software Version:	WL INSITE R3.8.4 (Build 5)	Calibration Version:	1

MEASURED CALIPER VALUES

Measurement	Shop	Field	Change	Control Limit On New Value
Pad Extension	3.75	3.71	-0.04	+/- 0.10
Ring Diameter	8.25	8.26	0.01	+/- 0.15

PASS/FAIL SUMMARY

Pad Extension Check:	Passed
Diameter Check:	Passed

SPECTRAL DENSITY SHOP CALIBRATION

Tool Name:	SDLT Pad - 10865884	Reference Calibration Date:	19-Sep-13 08:18:40
Engineer:	SHELDON INGERSOLL	Calibration Date:	19-Nov-13 11:40:39
Software Version:	WL INSITE R3.8.4 (Build 5)	Calibration Version:	1

Logging Source S/N: 5168GW

Aluminum Block S/N: LIBERAL

Density: 2.598g/cc

Pe: 3.170

Magnesium Block S/N: LIBERAL

Density: 1.684g/cc

Pe: 2.598

DENSITY CALIBRATION SUMMARY

Measurement	Previous Value	New Value	Control Limit
Near Bar Gain	1.0495	1.0464	0.90 - 1.10
Near Dens Gain	1.0132	1.0141	0.90 - 1.10
Near Peak Gain	1.0054	1.0122	0.90 - 1.10
Near Lith Gain	0.9823	0.9876	0.90 - 1.10
Far Bar Gain	1.0130	1.0153	0.90 - 1.10
Far Dens Gain	1.0009	0.9983	0.90 - 1.10
Far Peak Gain	0.9948	0.9929	0.90 - 1.10
Far Lith Gain	0.9633	0.9693	0.90 - 1.10
Near Bar Offset	-0.2477	-0.2148	NONE
Near Dens Offset	0.0515	0.0483	NONE
Near Peak Offset	0.0931	0.0409	NONE
Near Lith Offset	0.2387	0.2003	NONE
Far Bar Offset	0.0293	0.0112	NONE
Far Dens Offset	0.1028	0.1316	NONE
Far Peak Offset	0.1184	0.1394	NONE
Far Lith Offset	0.3075	0.2702	NONE
Near Bar Background	820.33	814.59	700 - 1450
Near Dens Background	273.67	271.61	230 - 480
Near Peak Background	118.78	118.46	100 - 210
Near Lith Background	145.79	144.35	125 - 260
Far Bar Background	505.61	504.83	450 - 900
Far Dens Background	198.48	197.77	175 - 345
Far Peak Background	77.38	77.67	70 - 140
Far Lith Background	81.67	81.18	75 - 145

CALIBRATION BLOCK SUMMARY

Measurement	Current Reading (Previous Coef)	Calibrated (New Coef)	Change	Control Limit On Change
MAGNESIUM				
Density (g/cc)	1.682	1.684	0.002	+/- 0.015
Pe	2.579	2.556	-0.023	+/- 0.150
ALUMINUM				
Density (g/cc)	2.596	2.598	0.002	+/- 0.01500
Pe	3.123	3.124	0.001	+/- 0.150

TOOL SUMMARY

Measurement	Near Detector		Far Detector	
	Value	Control Limits	Value	Control Limits
QUALITY				
Background	-0.0009	+/- 0.0110	-0.0009	+/- 0.0140
Magnesium Block	-0.0002	+/- 0.0110	-0.0014	+/- 0.0140
Aluminum Block	-0.0000	+/- 0.0110	-0.0000	+/- 0.0140
Resolution	9.11	6.00 - 11.50	8.86	6.00 - 11.50
Internal Verifier(B+D+P+L)	1349	1200 - 2700	861	800 - 1700

PASS/FAIL SUMMARY	
Background Quality Check:	Passed
Background Range Check:	Passed
Background Resolution Check:	Passed
Background Verification Check:	Passed
Magnesium Quality Check:	Passed
Aluminum Quality Check:	Passed
Gains Check:	Passed
Changes in Calibration Blocks:	Passed

SPECTRAL DENSITY FIELD CHECK

Tool Name: SDLT Pad - 10865884	Reference Calibration Date: 19-Nov-13 11:40:39
Engineer: SHELDON INGERSOLL	Calibration Date: 24-Nov-13 20:50:16
Software Version: WL INSITE R3.8.4 (Build 5)	Calibration Version: 1

Pad Temperature: 61.1 degF

DENSITY FIELD CALIBRATION SUMMARY				
Measurement	Shop	Field	Change	Control Limit +/-
Near (B+D+P+L) cps	1349.007	1353.790	4.783	14.851
Far (B+D+P+L) cps	861.455	861.823	0.368	16.069
Near Resolution	9.11	9.24	0.130	0.50
Far Resolution	8.86	9.04	0.180	1.00

PASS/FAIL SUMMARY	
Bkg Quality Check:	Passed
Bkg Resolution Check:	Passed
Bkg Verification Check:	Passed

CALIBRATION SUMMARY

Sensor	Shop	Field	Post	Difference	Tolerance	Units
GTET-11021139						
Gamma Ray Calibrator	269.6	278.1	-----	-8.5	+/- 9.00	api
DSNT-11055304						
Snow-Block Porosity	0.0675	0.0569	-----	0.0106	+/- 0.0150	decp
SDLT-11014296						
Pad Extension	3.75	3.71	-----	0.04	+/-0.10	in
Ring Diameter	8.25	8.33	-----	-0.08	+/-0.15	in
SDLT Pad-10865884						
Near(B+D+P+L)	1349.007	1353.790	-----	-4.783	+/-14.851	cps
Far(B+D+P+L)	861.455	861.823	-----	-0.368	+/-16.069	cps

INPUTS, DELAYS AND FILTERS TABLE

Mnemonic	Input Description	Delay (ft)	Filter Type	Filter Length (ft)
Depth Panel				
TENS	Tension	0.00	NO	
RWCH				
DHTN	Downhole Tension	0.00	BLK	0.000
SP Sub				
PLTC	Plot Control Mask	119.13	NO	
SP	Spontaneous Potential	119.13	BLK	1.250
SPR	Raw Spontaneous Potential	119.13	NO	
SPO	Spontaneous Potential Offset	119.13	NO	
GTET				
TPUL	Tension Pull	111.11	NO	
GR	Natural Gamma Ray API	111.11	TRI	1.750
GRU	Unfiltered Natural Gamma Ray API	111.11	NO	
EGR	Natural Gamma Ray API with Enhanced Vertical Resolution	111.11	W	1.416 , 0.750
ACCZ	Accelerometer Z	0.00	BLK	0.083
DEVI	Inclination	0.00	NO	
CSNG				
TPUL	Tension Pull	103.02	NO	
STAT	Status	103.02	NO	
FRMC	Tool Frame Count	103.02	BLK	0.250
TFRM	Total Frames	103.02	NO	
LSPD	Line Speed	103.02	BLK	0.250
CTIM	Accumulation time for sample	103.02	BLK	0.250
NOIS	Spectral Noise	103.02	BLK	0.250
STAB	Stabilizer Voltage in mv	103.02	BLK	0.250
STBP	Stabilizer 60 KEV Peak	103.02	BLK	0.250
AMER	Americium	103.02	BLK	0.250
FTMP	Flask PCB Temperature	103.02	BLK	0.250
SPEL	Low Energy Spectrum	103.02	BLK	0.250
SPEH	High Energy Spectrum	103.02	BLK	0.250
SSP	Stabilization Energy Spectrum	103.02	BLK	0.250
CSPC	CSNG Lo Hi Spectrum Data	103.02	NO	
ICT				
TPUL	Tension Pull	90.44	NO	
	Arm Potentiometer excitation V	87.65	NO	
	Caliper 1 measurement	90.44	BLK	1.250
	Caliper 2 measurement	90.44	BLK	1.250
	Caliper 3 measurement	90.44	BLK	1.250
	Caliper 4 measurement	90.44	BLK	1.250
	Caliper 5 measurement	90.44	BLK	1.250
	Caliper 6 measurement	90.44	BLK	1.250
	Caliper Global measurement	90.44	BLK	1.250
MOTI	Motor Current	87.65	NO	
MOT1	Motor Voltage Monitor 1	87.65	NO	
STA1	Status word #1	87.65	NO	
STA2	Status word #2	87.65	NO	

TAZ	Status word #2	87.03	NO
PRES	Caliper percentage of total compression of the spring	87.65	NO
HAZI	Hole Azimuth	90.44	NO
RB	Relative Bearing	90.44	NO
AZI1	PAD1 Azimuth	90.44	NO
DEVI	Inclination	90.44	NO
IDT			
TPUL	Tension Pull	81.07	NO
ACCX	Accelerometer X	81.07	NO
ACCY	Accelerometer Y	81.07	NO
ACCZ	Accelerometer Z	81.07	NO
MAGX	magnetometer x with unit	81.07	NO
MAGY	Magnetometer Y with unit	81.07	NO
MAGZ	magnetometer z with unit	81.07	NO
IAMP	Accelerometer Temperature	81.07	NO
MTMP	Magnetometer Temperature	81.07	NO
Wavesonic-I			
TPUL	Tension Pull	57.50	NO
DPSX	Dipole Source X Structurel	46.00	NO
DPSY	Dipole Source Y Structurel	46.00	NO
DPSM	Monopole Source Structure	46.00	NO
WVST	Wavesonic Compressed Data	57.50	NO
TPUL	Tension Pull	57.50	NO
XMS1	Wave Sonic Status Word 1	46.00	NO
XMS2	Wave Sonic Status Word 2	46.00	NO
XMS1	Wave Sonic XMITStatus Word 1	46.00	NO
XMS1	Wave Sonic XMITStatus Word 2	46.00	NO
F1HA	Dipole 1 HV After	46.00	NO
F1HB	Dipole 1 HV Before	46.00	NO
F2HA	Dipole 2 HV After	46.00	NO
F2HB	Dipole 2 HV Before	46.00	NO
F3HA	Monopole HV After	46.00	NO
F3HB	Monopole HV Before	46.00	NO
INVT	Input Voltage	46.00	NO
5VOL	5 Volts	46.00	NO
MI5A	Minus 5 Volts Analog	46.00	NO
ITMP	Instrument Temperature	46.00	NO
PL5A	Plus 5 Volts Analog	46.00	NO
5VD	Plus 5 Volts Digital	46.00	NO
TCUR	Tool Current	46.00	NO
SUPV	Supply Voltage	46.00	NO
PRVT	Preregulated voltage	46.00	NO
PRVT	Pre-regulated voltage Xmter	46.00	NO
TEMP	Temperature	46.00	NO
ACQN	Acquisition Number	46.00	NO
XDP	Delay Reference	57.50	NO
MITM	MIT Mode	57.50	NO
VERS	Version	46.00	NO
D1CT	Dipole 1 Compressed Word Count	57.50	NO
D2CT	Dipole 2 Compressed Word Count	57.50	NO
MCNT	Monopole Compressed Word Count	57.50	NO
SEQN	Sequence Number	46.00	NO
FREV	Firmware Revision	46.00	NO
MSMP	Monopole Sample Rate	46.00	NO

MSMP	Dipole Sample Rate	46.00	NO
MFWF	Monopole Firing Waveform	46.00	NO
MFRQ	Monopole Frequency	46.00	NO
MDLY	Monopole Delay	46.00	NO
DXWF	Dipole X Firing Waveform	46.00	NO
XFRQ	Dipole X Frequency	46.00	NO
XDLY	Dipole X Delay	46.00	NO
DYWF	Dipole Y Firing Waveform	46.00	NO
YFRQ	Dipole Y Frequency	46.00	NO
YDLY	Dipole Y Delay	46.00	NO
DPSX	Dipole Source X Structure1	46.00	NO
DPSY	Dipole Source Y Structure1	46.00	NO
DPSM	Monopole Source Structure	46.00	NO
WVST	Wavesonic Compressed Data	57.50	NO
AUTM	Auto Mode	46.00	NO
SONM	tool mode for sonic - 0 for normal or 3 for calibration	46.00	NO
MSL	Monopole Lower Travel Time	57.50	NO
MSH	Monopole Upper Travel Time	57.50	NO
MLFC	Monopole-1 Lower Filter Bandpass Frequency Cut-off	46.00	NO
MUFC	Monopole-1 Upper Filter Bandpass Frequency Cut-off	46.00	NO
DLTT	Dipole Lower Travel Time	46.00	NO
DUTT	Dipole Upper Travel Time	46.00	NO
DLFC	Dipole Lower Filter Bandpass Frequency Cut-off	46.00	NO
DUFC	Dipole Upper Filter Bandpass Frequency Cut-off	46.00	NO
MUTE	WaveSonic Mute/Enable Channels and Sides map	46.00	NO
MUTS	Mute/Enable Sides	46.00	NO
WSRB	Relative Bearing	57.50	NO
WSAZ	WSX Azimuth Pad 1	57.50	NO
TPUL	Tension Pull	57.50	NO
WMP	Summed array of Monopole for SIDES - A,B,C,D	57.50	NO
WXX	Dipole X for SIDES - A-C	57.50	NO
WYY	Dipole Y for SIDES - B-D	57.50	NO
WXY	Dipole X for SIDES - B-D	57.50	NO
WYX	Dipole Y for SIDES - A-C	57.50	NO
TPUL	Tension Pull	57.50	NO
WMA	Monopole Waveform Side A - Channel 1 to Channel 8 Receivers	57.50	NO
WMB	Monopole Waveform Side B - Channel 1 to Channel 8 Receivers	57.50	NO
WMC	Monopole Waveform Side C - Channel 1 to Channel 8 Receivers	57.50	NO
WMD	Monopole Waveform Side D - Channel 1 to Channel 8 Receivers	57.50	NO
WXA	Dipole X Waveform Side A - Channel 1 to Channel 8 Receivers	57.50	NO
WXB	Dipole X Waveform Side B - Channel 1 to Channel 8 Receivers	57.50	NO
WXC	Dipole X Waveform Side C - Channel 1 to Channel 8 Receivers	57.50	NO
WXD	Dipole X Waveform Side D - Channel 1 to Channel 8 Receivers	57.50	NO
WYA	Dipole Y Waveform Side A - Channel 1 to Channel 8 Receivers	57.50	NO
WYB	Dipole Y Waveform Side B - Channel 1 to Channel 8 Receivers	57.50	NO
WYC	Dipole Y Waveform Side C - Channel 1 to Channel 8 Receivers	57.50	NO
WYD	Dipole Y Waveform Side D - Channel 1 to Channel 8 Receivers	57.50	NO
GAR1	Gain Side A Receiver 1	46.00	NO
GAR2	Gain Side A Receiver 2	46.00	NO

GAR3	Gain Side A Receiver 3	46.00	NO	
GAR4	Gain Side A Receiver 4	46.00	NO	
GAR5	Gain Side A Receiver 5	46.00	NO	
GAR6	Gain Side A Receiver 6	46.00	NO	
GAR7	Gain Side A Receiver 7	46.00	NO	
GAR8	Gain Side A Receiver 8	46.00	NO	
GBR1	Gain Side B Receiver 1	46.00	NO	
GBR2	Gain Side B Receiver 2	46.00	NO	
GBR3	Gain Side B Receiver 3	46.00	NO	
GBR4	Gain Side B Receiver 4	46.00	NO	
GBR5	Gain Side B Receiver 5	46.00	NO	
GBR6	Gain Side B Receiver 6	46.00	NO	
GBR7	Gain Side B Receiver 7	46.00	NO	
GBR8	Gain Side B Receiver 8	46.00	NO	
GCR1	Gain Side C Receiver 1	46.00	NO	
GCR2	Gain Side C Receiver 2	46.00	NO	
GCR3	Gain Side C Receiver 3	46.00	NO	
GCR4	Gain Side C Receiver 4	46.00	NO	
GCR5	Gain Side C Receiver 5	46.00	NO	
GCR6	Gain Side C Receiver 6	46.00	NO	
GCR7	Gain Side C Receiver 7	46.00	NO	
GCR8	Gain Side C Receiver 8	46.00	NO	
GDR1	Gain Side D Receiver 1	46.00	NO	
GDR2	Gain Side D Receiver 2	46.00	NO	
GDR3	Gain Side D Receiver 3	46.00	NO	
GDR4	Gain Side D Receiver 4	46.00	NO	
GDR5	Gain Side D Receiver 5	46.00	NO	
GDR6	Gain Side D Receiver 6	46.00	NO	
GDR7	Gain Side D Receiver 7	46.00	NO	
GDR8	Gain Side D Receiver 8	46.00	NO	
DSNT				
TPUL	Tension Pull	32.54	NO	
RNDS	Near Detector Telemetry Counts	32.64	BLK	1.417
RFDS	Far Detector Telemetry Counts	33.39	TRI	0.583
DN TT	DSN Tool Temperature	32.64	NO	
DSNS	DSN Tool Status	32.54	NO	
ERND	Near Detector Telemetry Counts EVR	32.64	BLK	0.000
ERFD	Far Detector Telemetry Counts EVR	33.39	BLK	0.000
ENTM	DSN Tool Temperature EVR	32.64	NO	
SDLT				
TPUL	Tension Pull	22.65	NO	
PCAL	Pad Caliper	22.65	TRI	0.250
ACAL	Arm Caliper	22.65	TRI	0.250
ACRt Sonde				
TPUL	Tension Pull	2.97	NO	
F1R1	ACRT 12KHz - 80in R value	9.22	BLK	0.000
F1X1	ACRT 12KHz - 80in X value	9.22	BLK	0.000
F1R2	ACRT 12KHz - 50in R value	6.72	BLK	0.000
F1X2	ACRT 12KHz - 50in X value	6.72	BLK	0.000
F1R3	ACRT 12KHz - 29in R value	5.22	BLK	0.000
F1X3	ACRT 12KHz - 29in X value	5.22	BLK	0.000
F1R4	ACRT 12KHz - 17in R value	4.22	BLK	0.000
F1X4	ACRT 12KHz - 17in X value	4.22	BLK	0.000

F1X4	ACRT 12KHz - 17in X value	4.22	BLK	0.000
F1R5	ACRT 12KHz - 10in R value	3.72	BLK	0.000
F1X5	ACRT 12KHz - 10in X value	3.72	BLK	0.000
F1R6	ACRT 12KHz - 6in R value	3.47	BLK	0.000
F1X6	ACRT 12KHz - 6in X value	3.47	BLK	0.000
F2R1	ACRT 36KHz - 80in R value	9.22	BLK	0.000
F2X1	ACRT 36KHz - 80in X value	9.22	BLK	0.000
F2R2	ACRT 36KHz - 50in R value	6.72	BLK	0.000
F2X2	ACRT 36KHz - 50in X value	6.72	BLK	0.000
F2R3	ACRT 36KHz - 29in R value	5.22	BLK	0.000
F2X3	ACRT 36KHz - 29in X value	5.22	BLK	0.000
F2R4	ACRT 36KHz - 17in R value	4.22	BLK	0.000
F2X4	ACRT 36KHz - 17in X value	4.22	BLK	0.000
F2R5	ACRT 36KHz - 10in R value	3.72	BLK	0.000
F2X5	ACRT 36KHz - 10in X value	3.72	BLK	0.000
F2R6	ACRT 36KHz - 6in R value	3.47	BLK	0.000
F2X6	ACRT 36KHz - 6in X value	3.47	BLK	0.000
F3R1	ACRT 72KHz - 80in R value	9.22	BLK	0.000
F3X1	ACRT 72KHz - 80in X value	9.22	BLK	0.000
F3R2	ACRT 72KHz - 50in R value	6.72	BLK	0.000
F3X2	ACRT 72KHz - 50in X value	6.72	BLK	0.000
F3R3	ACRT 72KHz - 29in R value	5.22	BLK	0.000
F3X3	ACRT 72KHz - 29in X value	5.22	BLK	0.000
F3R4	ACRT 72KHz - 17in R value	4.22	BLK	0.000
F3X4	ACRT 72KHz - 17in X value	4.22	BLK	0.000
F3R5	ACRT 72KHz - 10in R value	3.72	BLK	0.000
F3X5	ACRT 72KHz - 10in X value	3.72	BLK	0.000
F3R6	ACRT 72KHz - 6in R value	3.47	BLK	0.000
F3X6	ACRT 72KHz - 6in X value	3.47	BLK	0.000
RMUD	Mud Resistivity	12.76	BLK	0.000
F1RT	Transmitter Current Raw 12K X Receiver	2.97	BLK	0.000
F1XT	Transmitter Reference 12 KHz Imaginary Signal	2.97	BLK	0.000
F2RT	Transmitter Reference 36 KHz Real Signal	2.97	BLK	0.000
F2XT	Transmitter Reference 36 KHz Imaginary Signal	2.97	BLK	0.000
F3RT	Transmitter Reference 72 KHz Real Signal	2.97	BLK	0.000
F3XT	Transmitter Reference 72 KHz Imaginary Signal	2.97	BLK	0.000
TFPU	Upper Feedpipe Temperature Calculated	2.97	BLK	0.000
TFPL	Lower Feedpipe Temperature Calculated	2.97	BLK	0.000
ITMP	Instrument Temperature	2.97	BLK	0.000
TCVA	Temperature Correction Values Loop Off	2.97	NO	
TIDV	Instrument Temperature Derivative	2.97	NO	
TUDV	Upper Temperature Derivative	2.97	NO	
TLDV	Lower Temperature Derivative	2.97	NO	
TRBD	Receiver Board Temperature	2.97	NO	
SDLT Pad				
TPUL	Tension Pull	22.64	NO	
NAB	Near Above	22.46	BLK	0.920
NHI	Near Cesium High	22.46	BLK	0.920
NLO	Near Cesium Low	22.46	BLK	0.920
NVA	Near Valley	22.46	BLK	0.920
NBA	Near Barite	22.46	BLK	0.920
NDE	Near Density	22.46	BLK	0.920
NPK	Near Peak	22.46	BLK	0.920
NLI	Near Lithology	22.46	BLK	0.920
NBAU	Near Barite Unfiltered	22.46	BLK	0.250

NLIU	Near Lithology Unfiltered	22.46	BLK	0.250
FAB	Far Above	22.81	BLK	0.250
FHI	Far Cesium High	22.81	BLK	0.250
FLO	Far Cesium Low	22.81	BLK	0.250
FVA	Far Valley	22.81	BLK	0.250
FBA	Far Barite	22.81	BLK	0.250
FDE	Far Density	22.81	BLK	0.250
FPK	Far Peak	22.81	BLK	0.250
FLI	Far Lithology	22.81	BLK	0.250
PTMP	Pad Temperature	22.65	BLK	0.920
NHV	Near Detector High Voltage	22.04	NO	
FHV	Far Detector High Voltage	22.04	NO	
ITMP	Instrument Temperature	22.04	NO	
DDHV	Detector High Voltage	22.04	NO	

Microlog Pad

TPUL	Tension Pull	22.83	NO	
MINV	Microlog Lateral	22.83	BLK	0.750
MNOR	Microlog Normal	22.83	BLK	0.750

Data: SIMONS_1736_112\0001 SP-GTET-CSNG-ICT-IDT-WAVE-FLEX-DSN-SDL-ACRT-CH\006 25-Nov-13 09:21 Up @5050.3f Date: 25-Nov-13 12:45:00

HALLIBURTON Plot Time: 25-Nov-13 15:44:11
Plot Range: 1495.75 ft to 5049.75 ft
Data: SIMONS_1736_112\Well Based\RR1 CASING\
Plot File: \\-LOCAL-\SIMONS_1736_112\Well Based\POROSITY\AHV_2_IQ_LIB

ANNULAR HOLE VOLUME PLOT

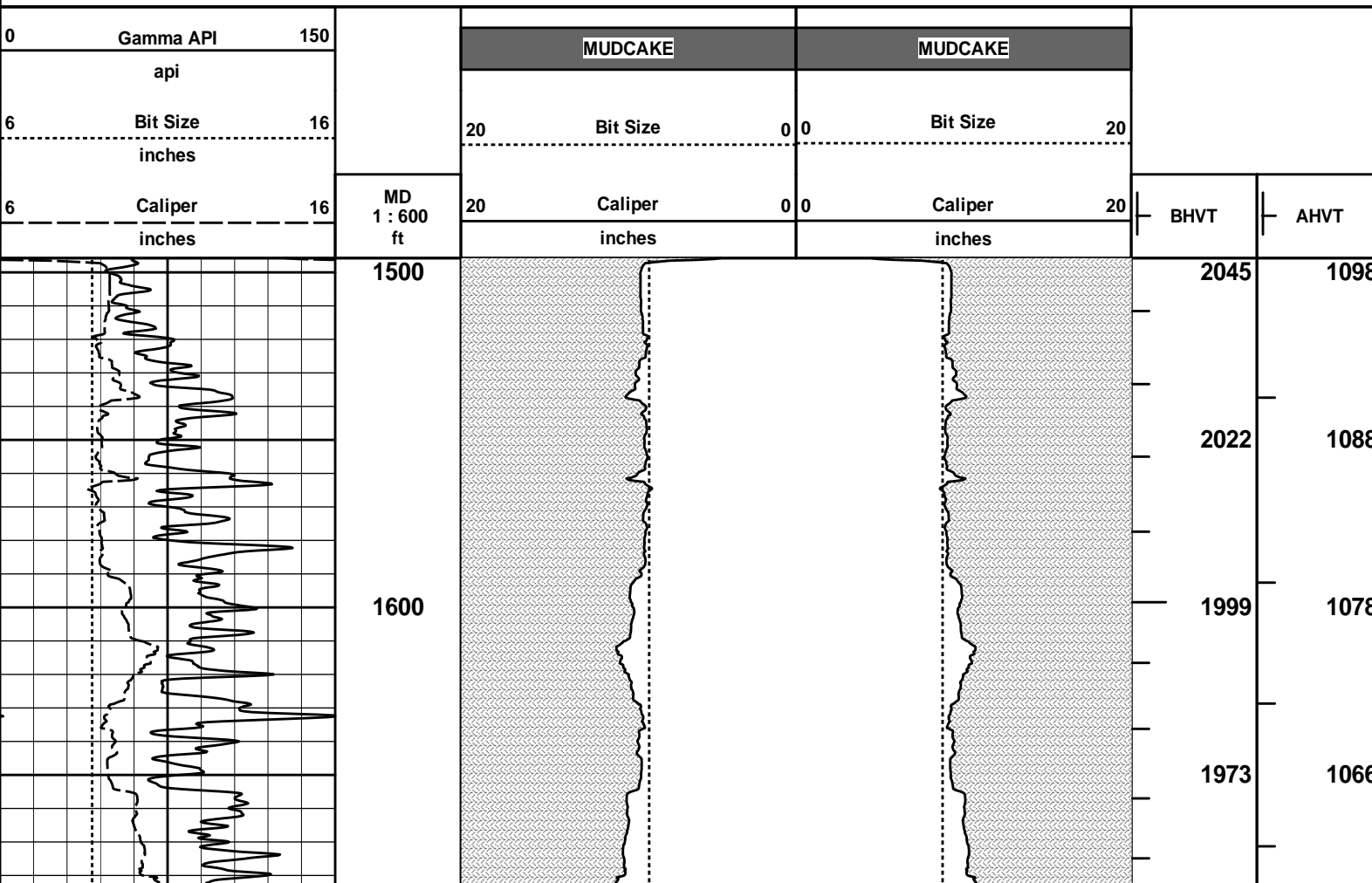

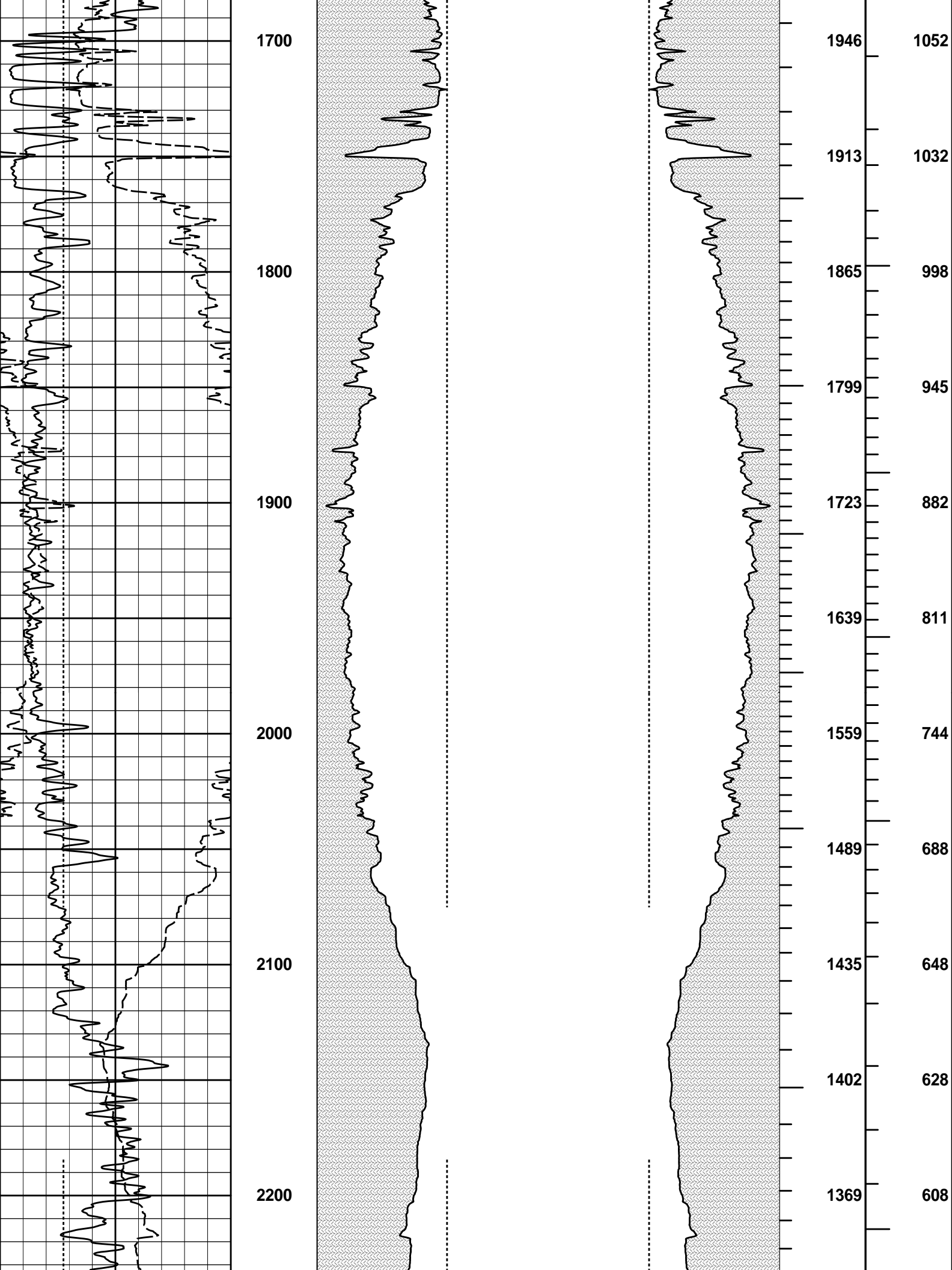

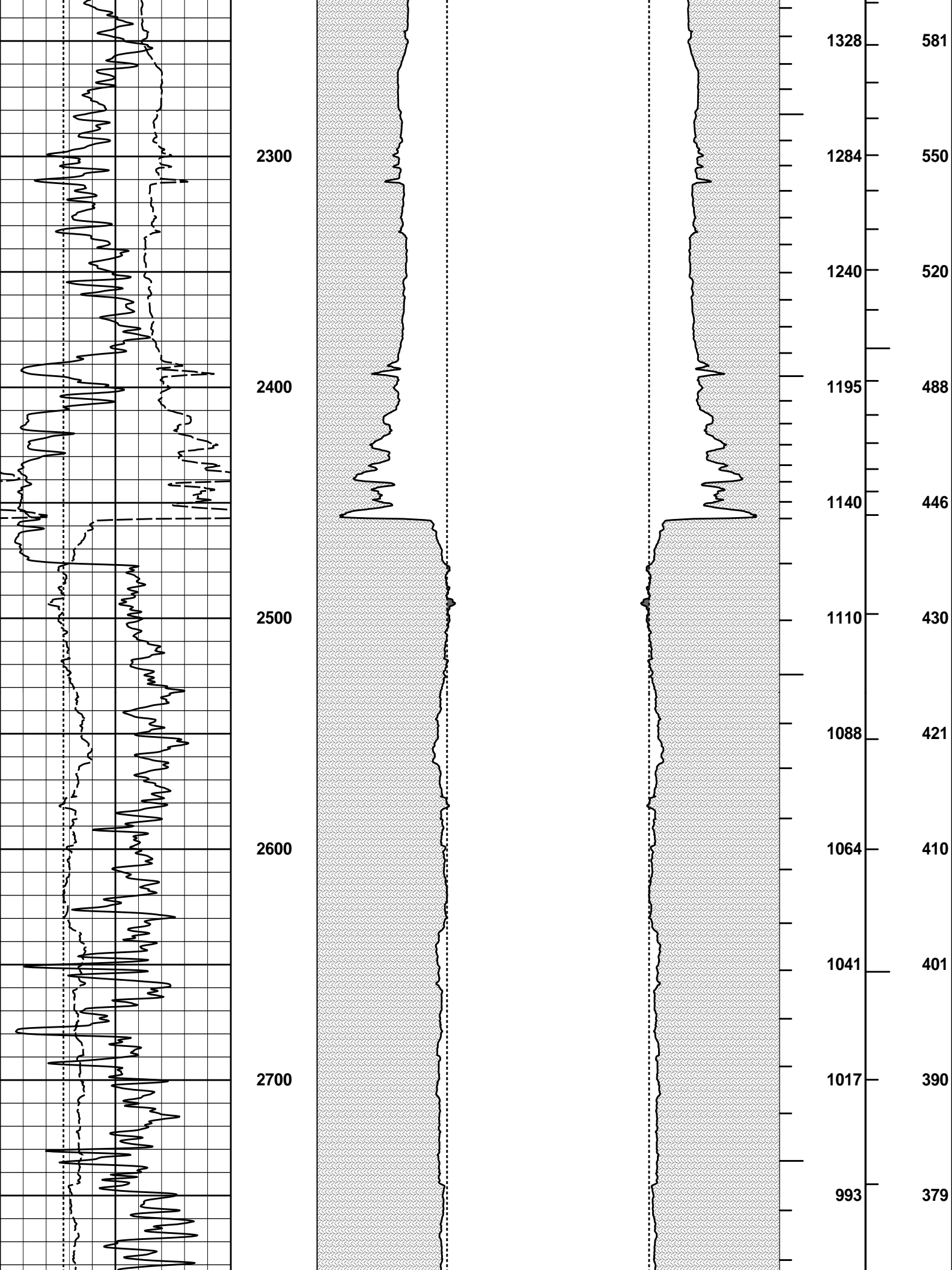

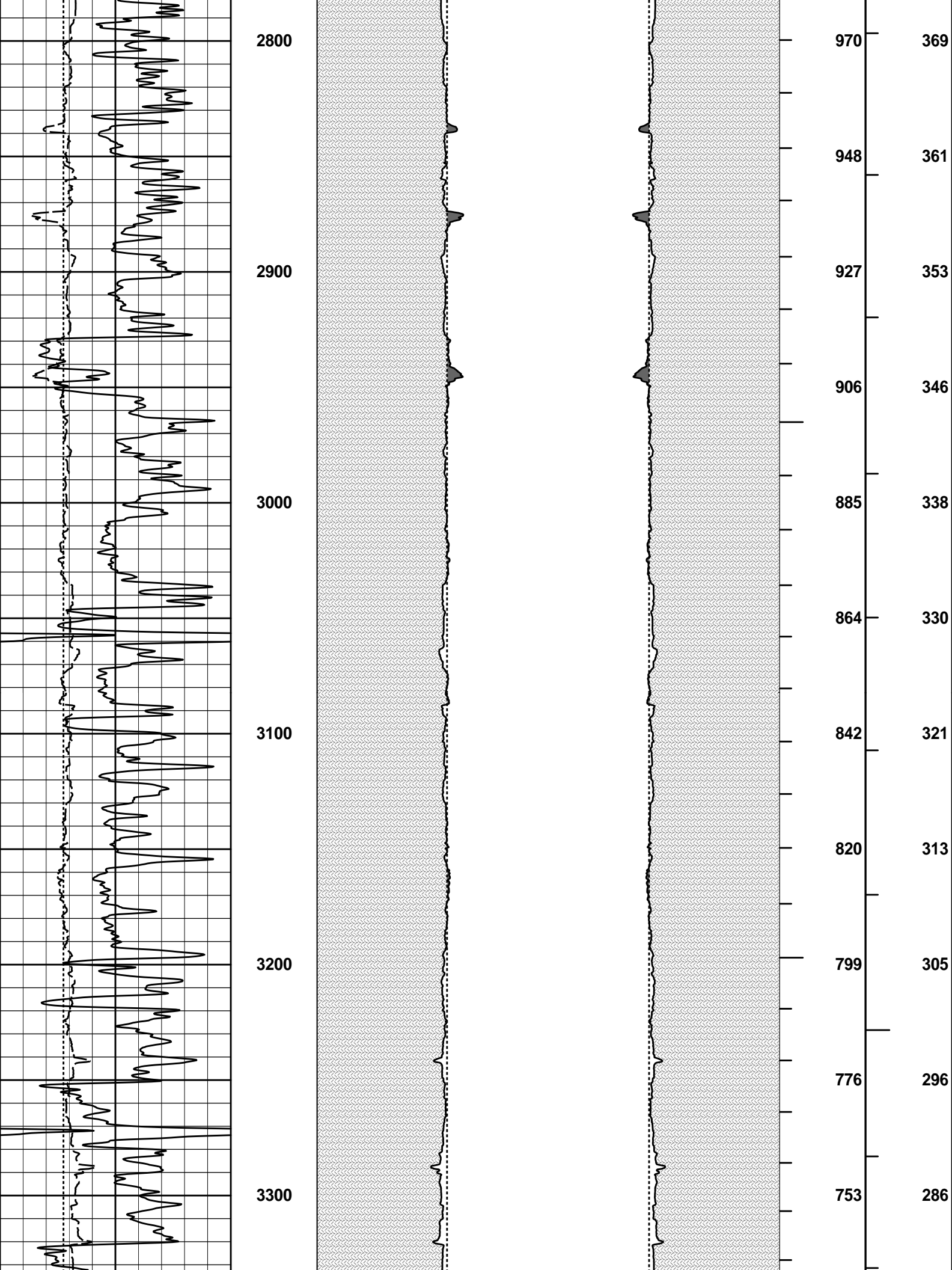

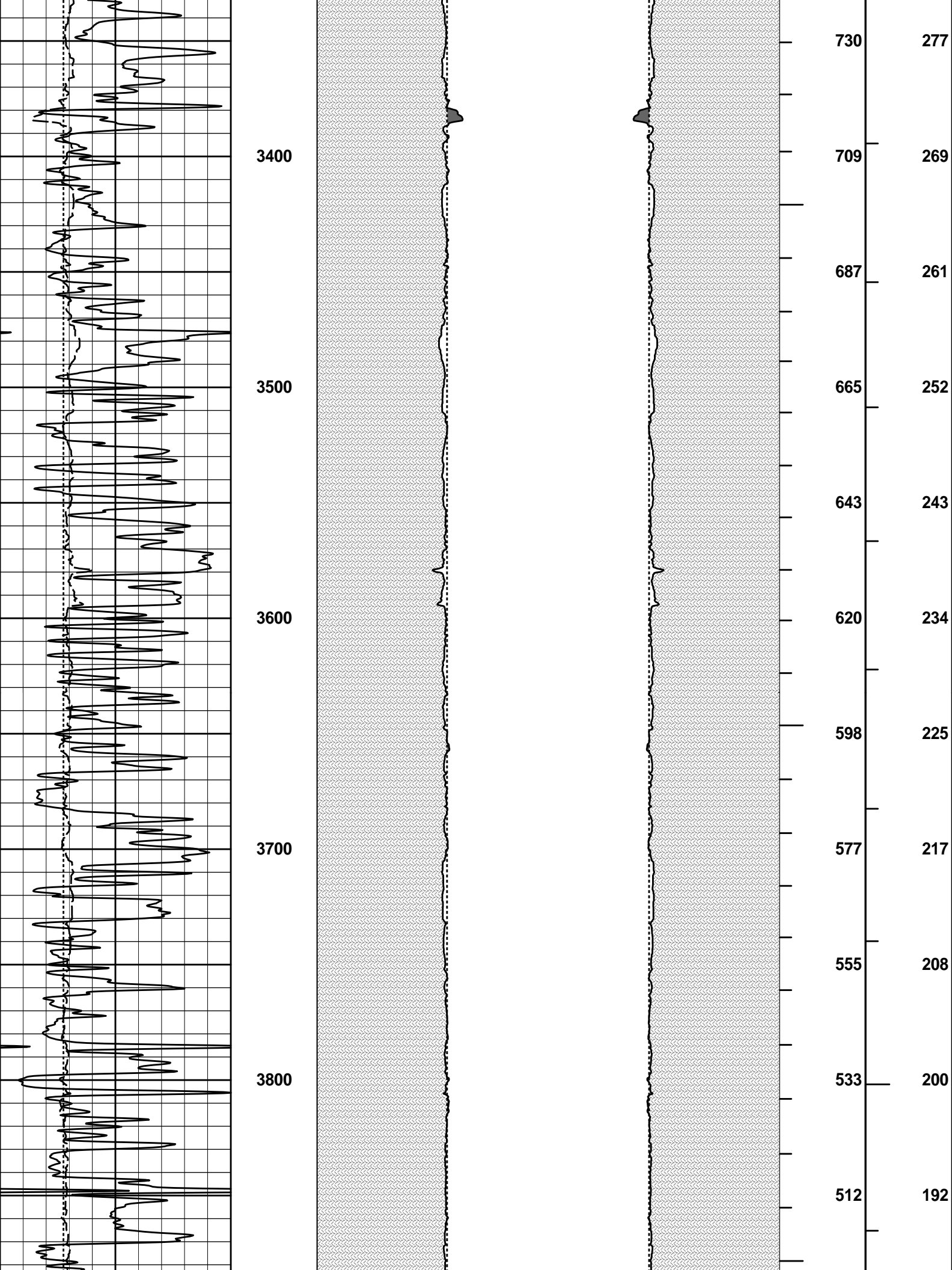

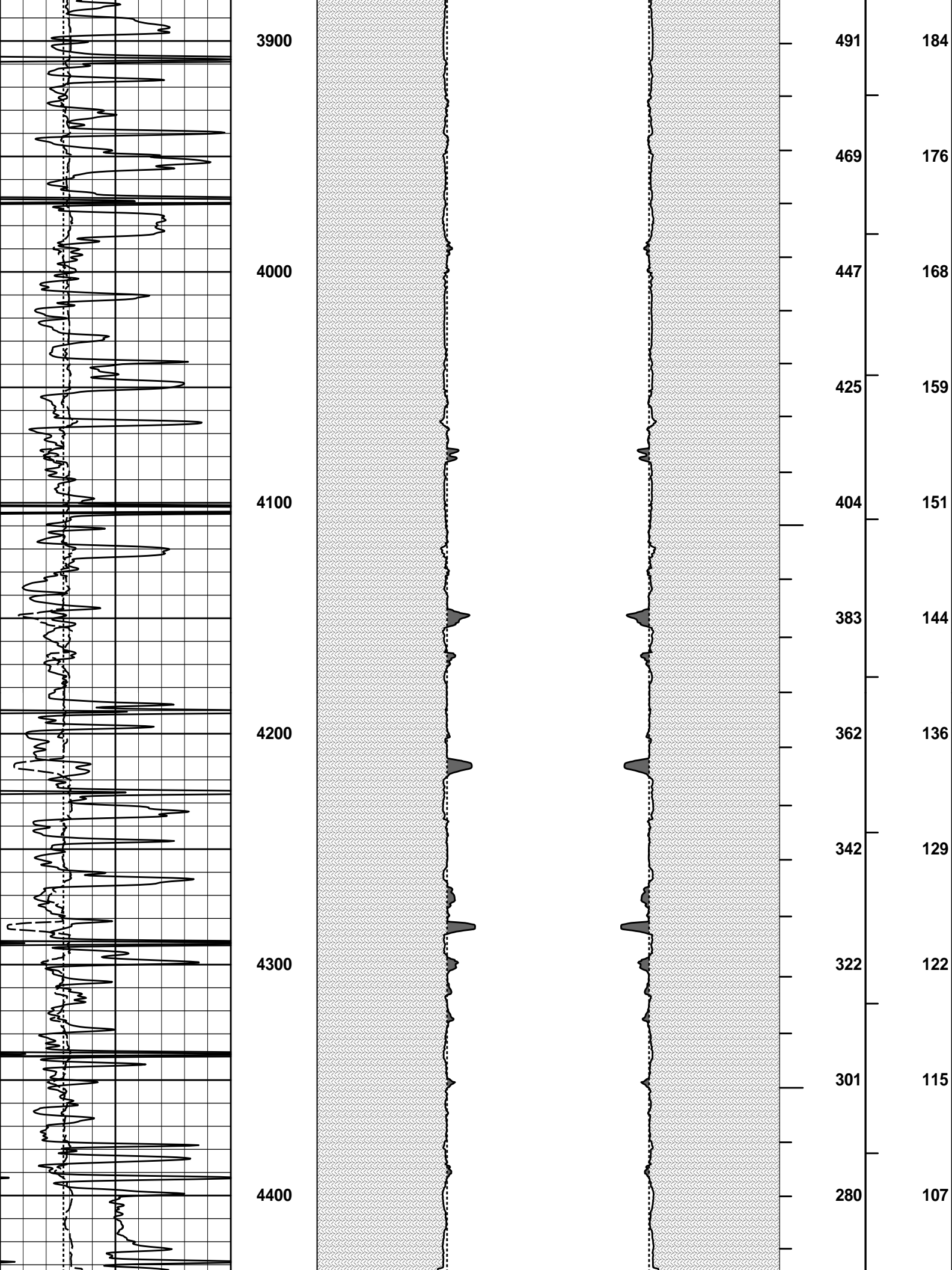

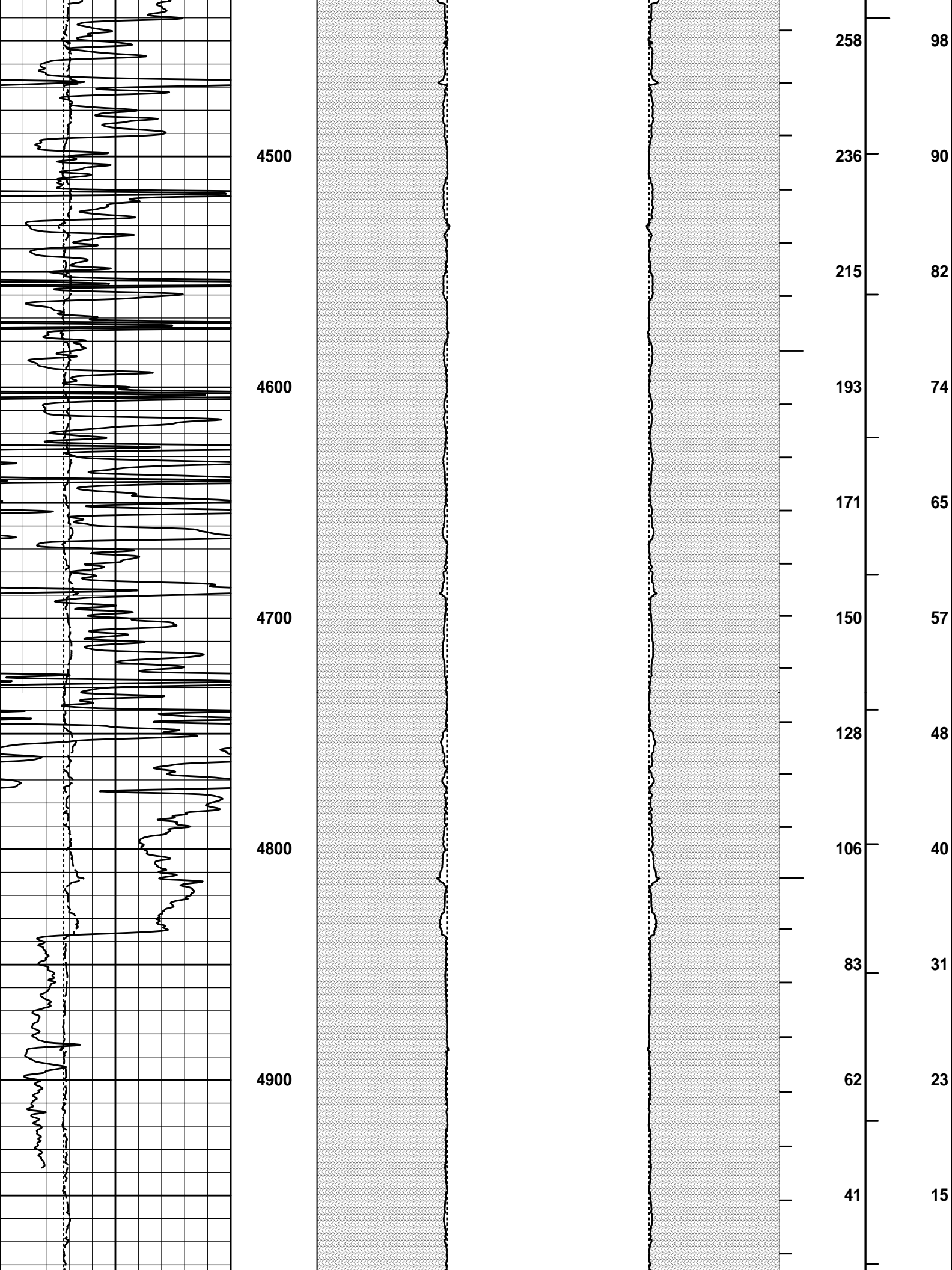

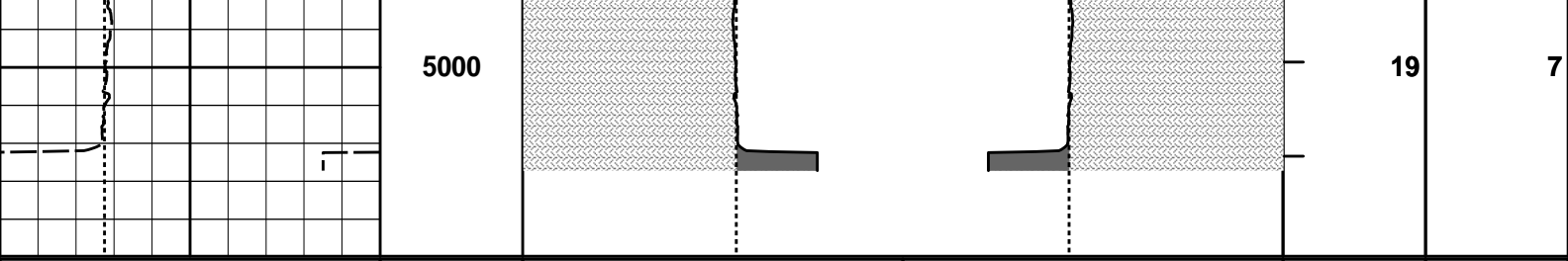

6	Caliper	16	MD 1 : 600 ft	20	Caliper	0 0	20	BHVT	AHVT
	inches					inches			
6	Bit Size	16			20	Bit Size	0 0	20	
	inches								
0	Gamma API	150							
	api								
					MUDCAKE		MUDCAKE		

HALLIBURTON

Plot Time: 25-Nov-13 15:44:17
 Plot Range: 1495.75 ft to 5049.75 ft
 Data: SIMONS_1736_112\Well Based\R1 CASING\
 Plot File: \\-LOCAL-SIMONS_1736_112\Well Based\POROSITY\AHV_2_IQ_LIB

ANNULAR HOLE VOLUME PLOT

COMPANY	SANDRIDGE ENERGY		
WELL	SIMONS 1736 1-12		
FIELD	BEAVER CLIFF NW		
COUNTY	WICHITA	STATE	KANSAS

HALLIBURTON

SPECTRAL DENSITY
 DUAL SPACED NEUTRON
 LOG