



Weatherford[®]

MICRORESISTIVITY LOG

COMPANY

SHAKESPEARE OIL CO., INC.

WELL

RUDOLPH 1-23

FIELD

WILDCAT

PROVINCE/COUNTY

SCOTT

COUNTRY/STATE

U.S.A. / KANSAS

LOCATION

1300' FNL & 1050' FWL

PERMIT NUMBER

SE SE NW NW

SEC 23

TWP 17S

RGE 33W

Other Services

Latitude

38.565719897

MAIMFE

MPD/MDN

Longitude

-100.940172130

API Number

15-171-21114

Permanent Datum GL, Elevation 3016 feet

Log Measured From KB

Drilling Measured From KB @ 10 FEET

Date

10-DEC-2014

Run Number

ONE

Service Order

7036-105380343

Depth Driller

4770.00 feet

Depth Logger

4775.00 feet

First Reading

4741.76 feet

Last Reading

3800.00 feet

Casing Driller

267.00 feet

Casing Logger

265.00 feet

Bit Size

7.875 inches

Hole Fluid Type

CHEMICAL

Density / Viscosity

9.20 lb/USg 58.00 CP

PH / Fluid Loss

10.50 6.40 ml/30Min

Sample Source

MUDPIT

Rm @ Measured Temp

0.598 @ 75.0 ohm-m

Rmf @ Measured Temp

0.479 @ 75.0 ohm-m

Rmc @ Measured Temp

0.718 @ 75.0 ohm-m

Source Rmf / Rmc

CALC CALC

Rm @ BHT

0.386 @ 119.0 ohm-m

Time Since Circulation

4.5 HOURS

Max Recorded Temp

119.00 deg F

Equipment / Base

13096 LIB

Recorded By

DEREK CARTER

Witnessed By

TIM PRIEST

JOB #

LB14-377

Elevations:
KB 3026.00
DF 3024.00
GL 3016.00

BOREHOLE RECORD

Last Edited: 10-DEC-2014 03:16

Bit Size inches	Depth From feet	Depth To feet
7.875	267.00	4770.00

CASING RECORD

Type	Size inches	Depth From feet	Shoe Depth feet	Weight pounds/ft
SURFACE	8.625	0.00	267.00	24.00

REMARKS

- SOFTWARE ISSUE: WLS 14.05.5280
- TOOLSTRING: MCG, MML, MDN, MPD, MFE, MAI RUN IN COMBINATION
- HARDWARE:
MDN: DUAL BOWSPRING ECCENTRALIZER
MFE: 1 X 0.5 INCH STANDOFF
MAI: 2 X 0.5 INCH STANDOFF
- 2.71 G/CC LIMESTONE DENSITY MATRIX USED TO CALCULATE POROSITY
- BOREHOLE RUGOSITY, TIGHT PULLS, AND WASHOUTS WILL AFFECT DATA QUALITY
- ALL INTERVALS LOGGED AND SCALED PER CUSTOMER'S REQUEST
- TOTAL HOLE VOLUME FROM TD TO 3800 FT.: 320 CU.FT.
- ANNUJ AR HOLE VOLUME WITH 5.5 INCH PRODUCTION CASING FROM TD TO 3800 FT.: 160 CU.FT.

- RIG: H. D. DRILLING #2
 - ENGINEER: DEREK CARTER
 - OPERATOR: CARLOS RAMIREZ

In interpreting, communicating or providing information and/or making recommendations, either written or oral, as to logs or test or other data, type or amount of material, or Work or other service to be furnished, or manner of performance, or in predicting results to be obtained, the Contractor will give the Company the benefit of the Contractor's best judgment based on its experience and will perform all such Work in a good and workmanlike manner. Any interpretation of test or other data, and any recommendation or reservoir description based upon such interpretations, are opinions based upon inferences from measurements and empirical relationships and assumptions, which inferences and assumptions are not infallible, and with respect to which professional engineers and analysts may differ. ACCORDINGLY ANY INTERPRETATION OR RECOMMENDATION RESULTING FROM THE SERVICES WILL BE AT THE SOLE RISK OF THE COMPANY, AND THE CONTRACTOR CANNOT AND DOES NOT WARRANT THE ACCURACY, CORRECTNESS OR COMPLETENESS OF ANY SUCH INTERPRETATION OR RECOMMENDATION, WHICH INTERPRETATIONS AND RECOMMENDATIONS SHOULD NOT, THEREFORE, UNDER ANY CIRCUMSTANCES BE RELIED UPON AS THE SOLE OR MAIN BASIS FOR ANY DRILLING, COMPLETION, WELL TREATMENT, PRODUCTION OR FINANCIAL DECISION, OR ANY PROCEDURE INVOLVING ANY RISK TO THE SAFETY OF ANY DRILLING ACTIVITY, DRILLING RIG OR ITS CREW OR ANY OTHER INDIVIDUAL. THE COMPANY HAS FULL RESPONSIBILITY FOR ALL DECISIONS CONCERNING THE SERVICES.

5 INCH MAIN

Depth Based Data - Maximum Sampling Increment 10.0cm Plotted on 10-DEC-2014 10:26
 Filename: C:\Minimus 14.05\Log Data\Shakespeare Rudolph 1-23\Shakespeare Rudolph 1-23 Main.dta Recorded on 10-DEC-2014 08:02
 System Versions: Logged with 14.05.5280 Plotted with 14.05.5280

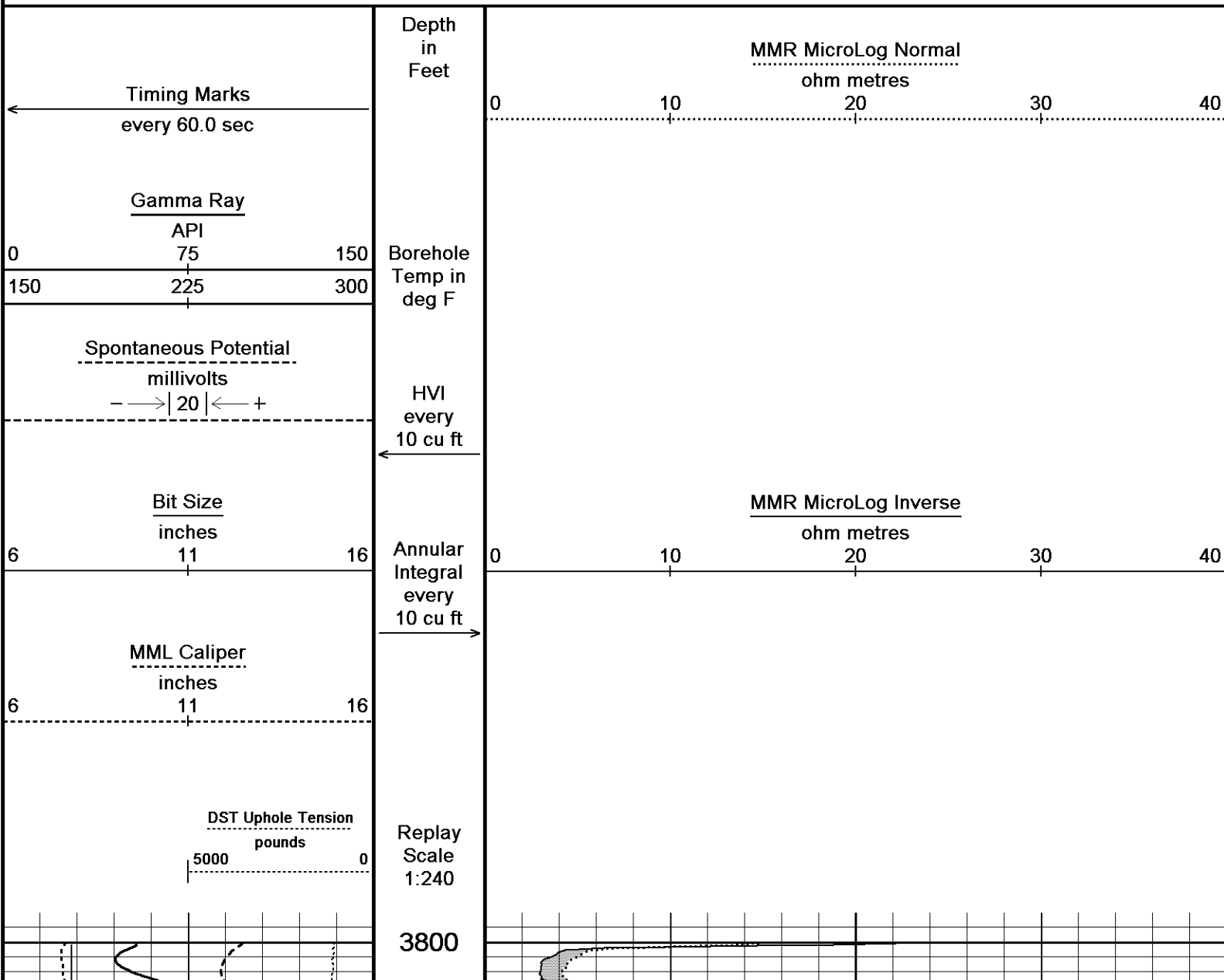

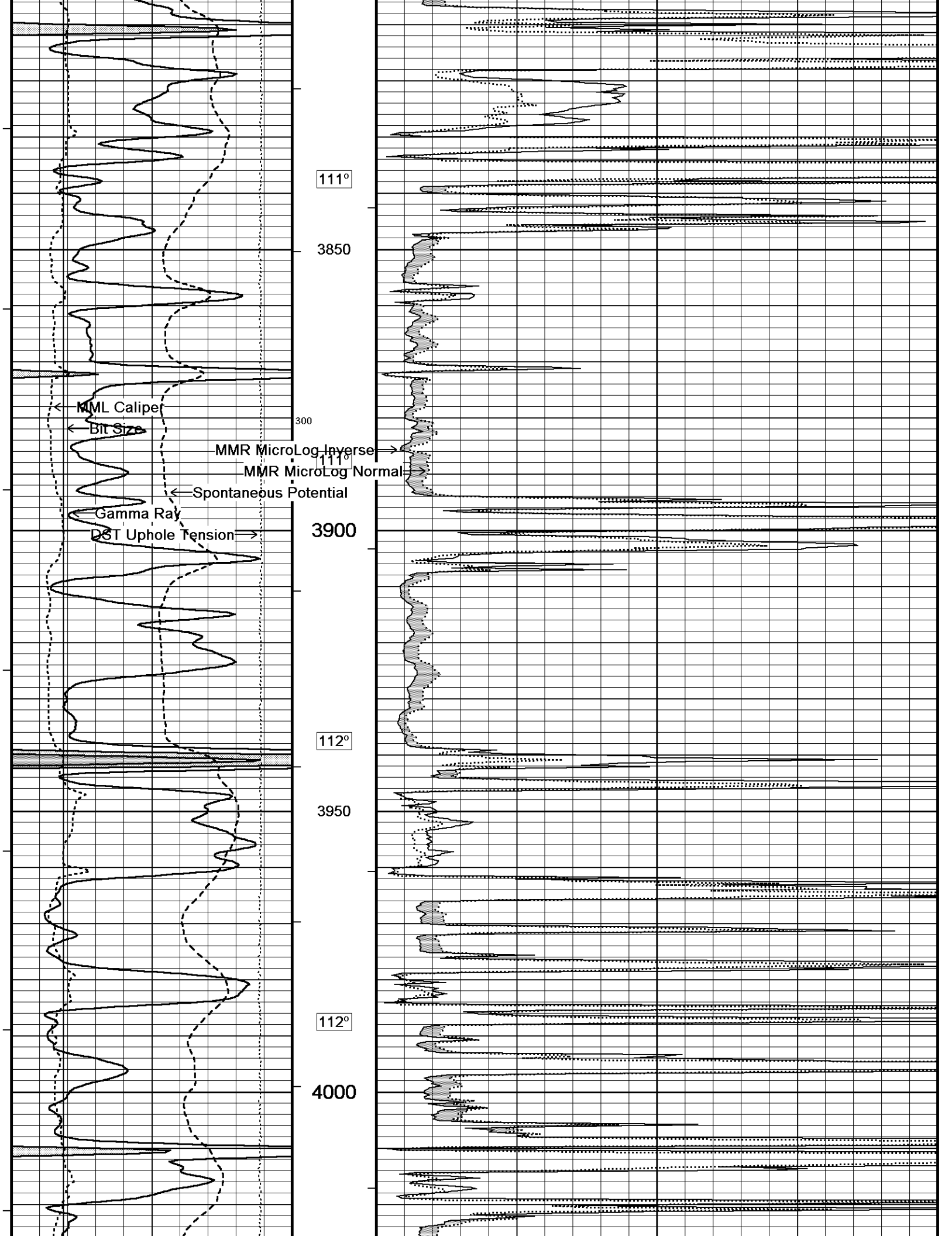

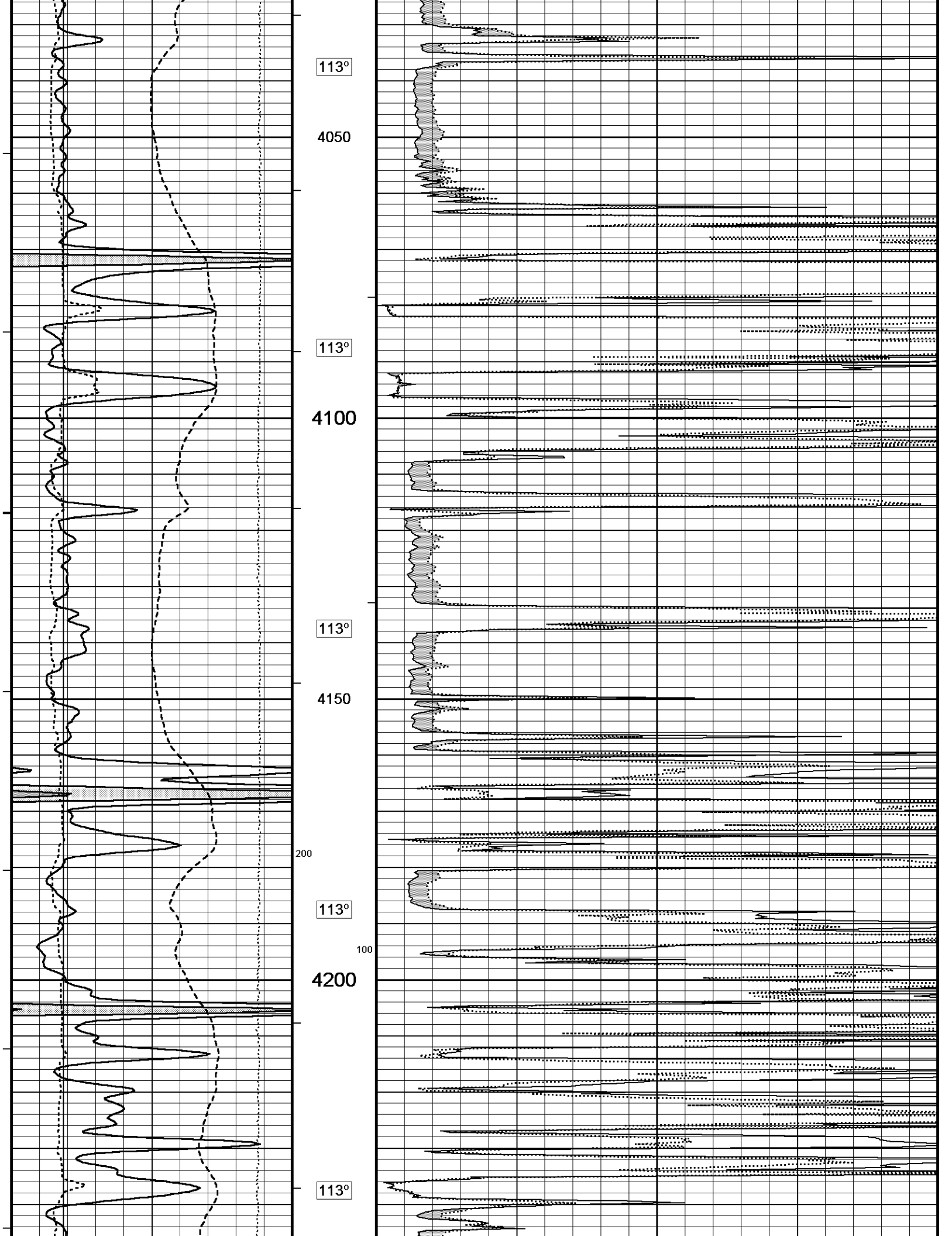

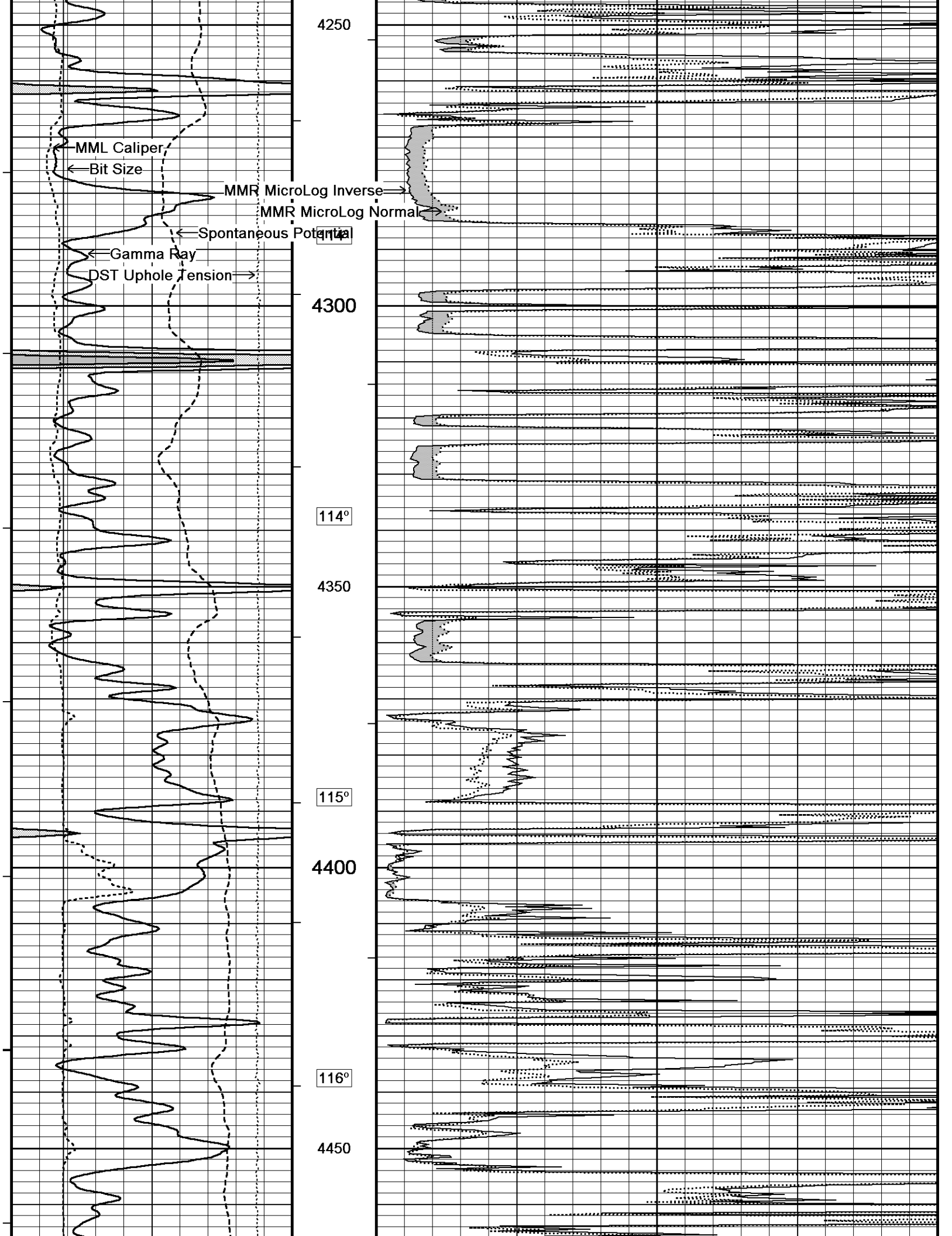

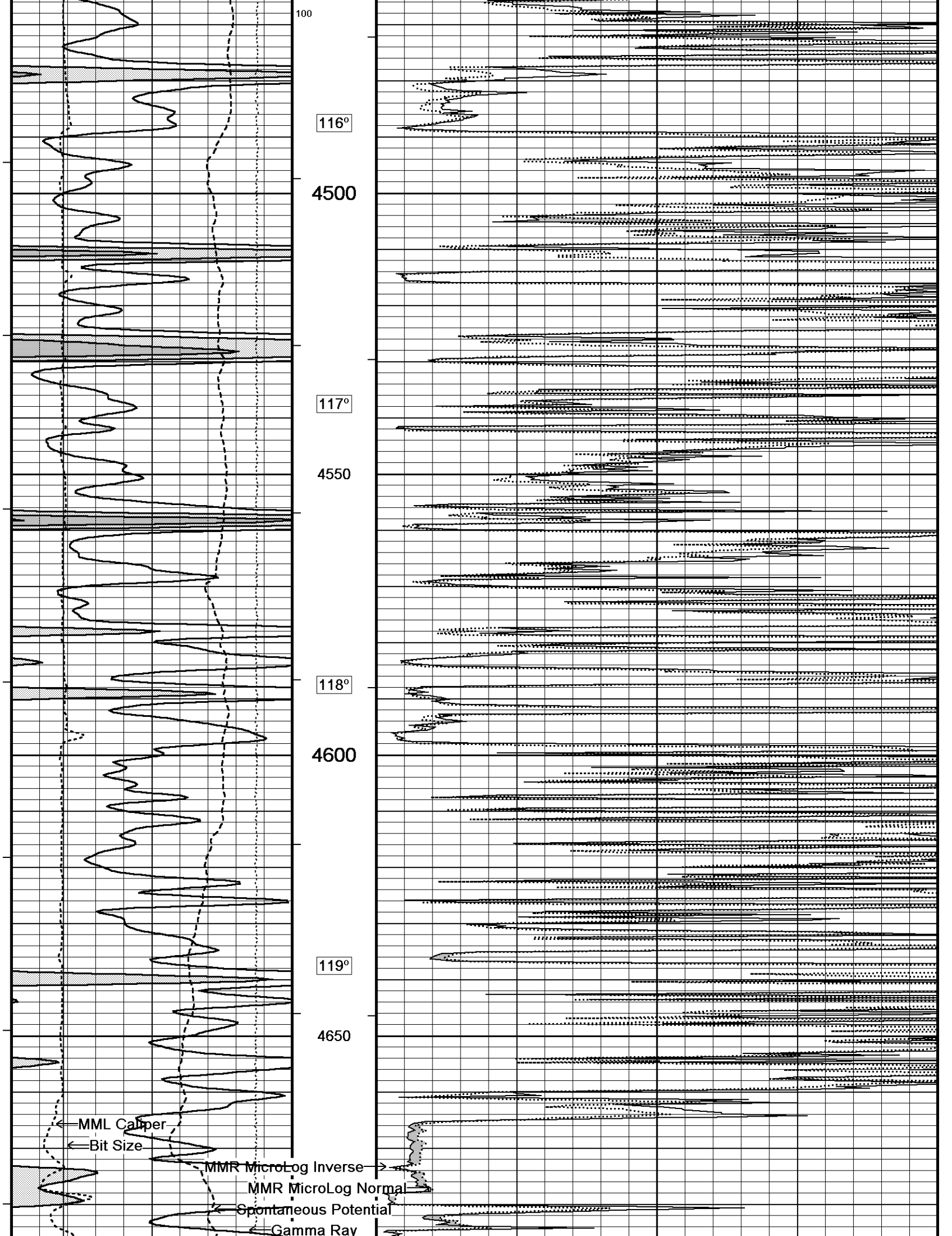

116°

4500

117°

4550

118°

4600

119°

4650

← MML Caliper
← Bit Size

MMR MicroLog Inverse →

MMR MicroLog Normal

← Spontaneous Potential

← Gamma Ray

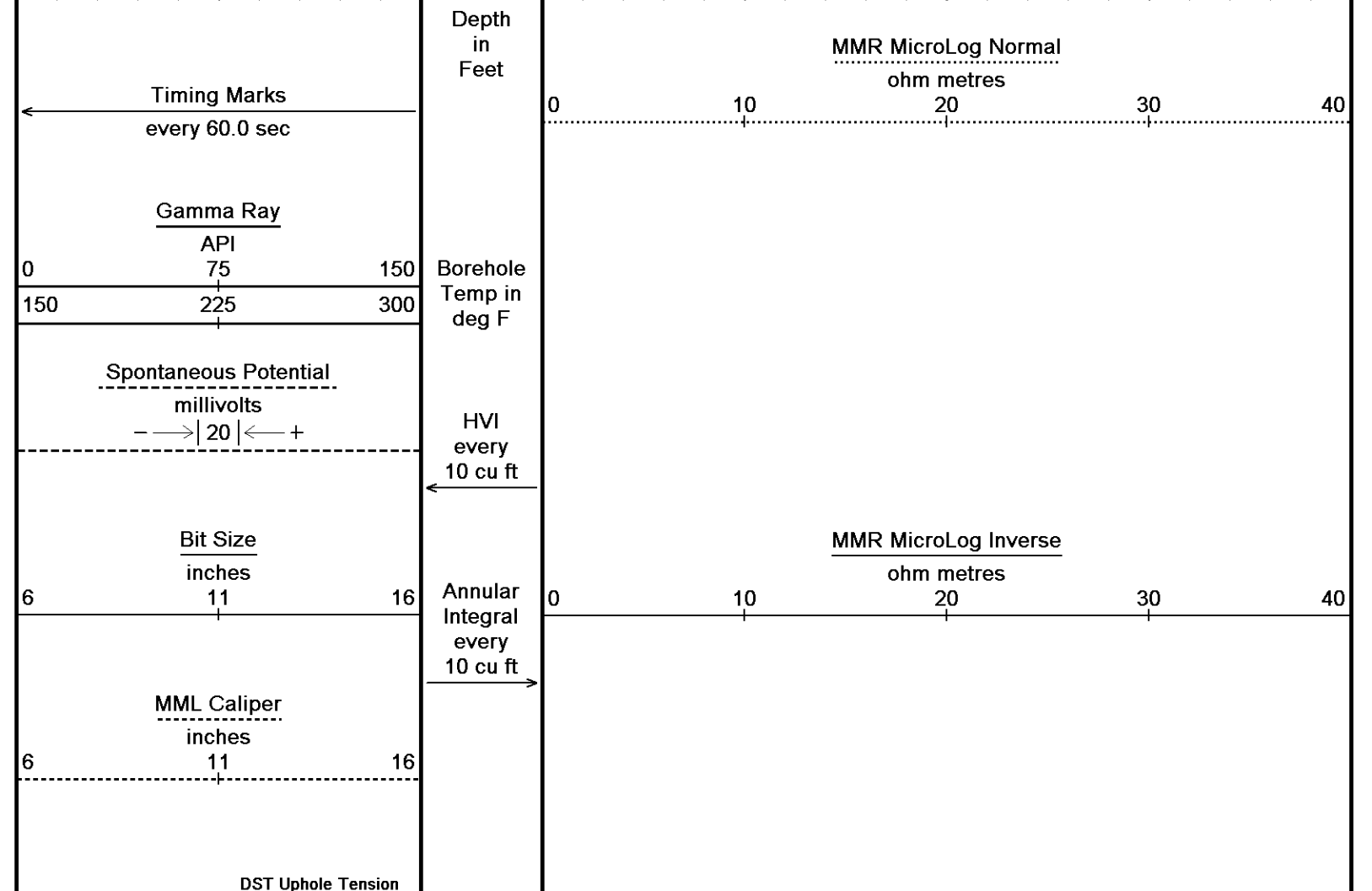
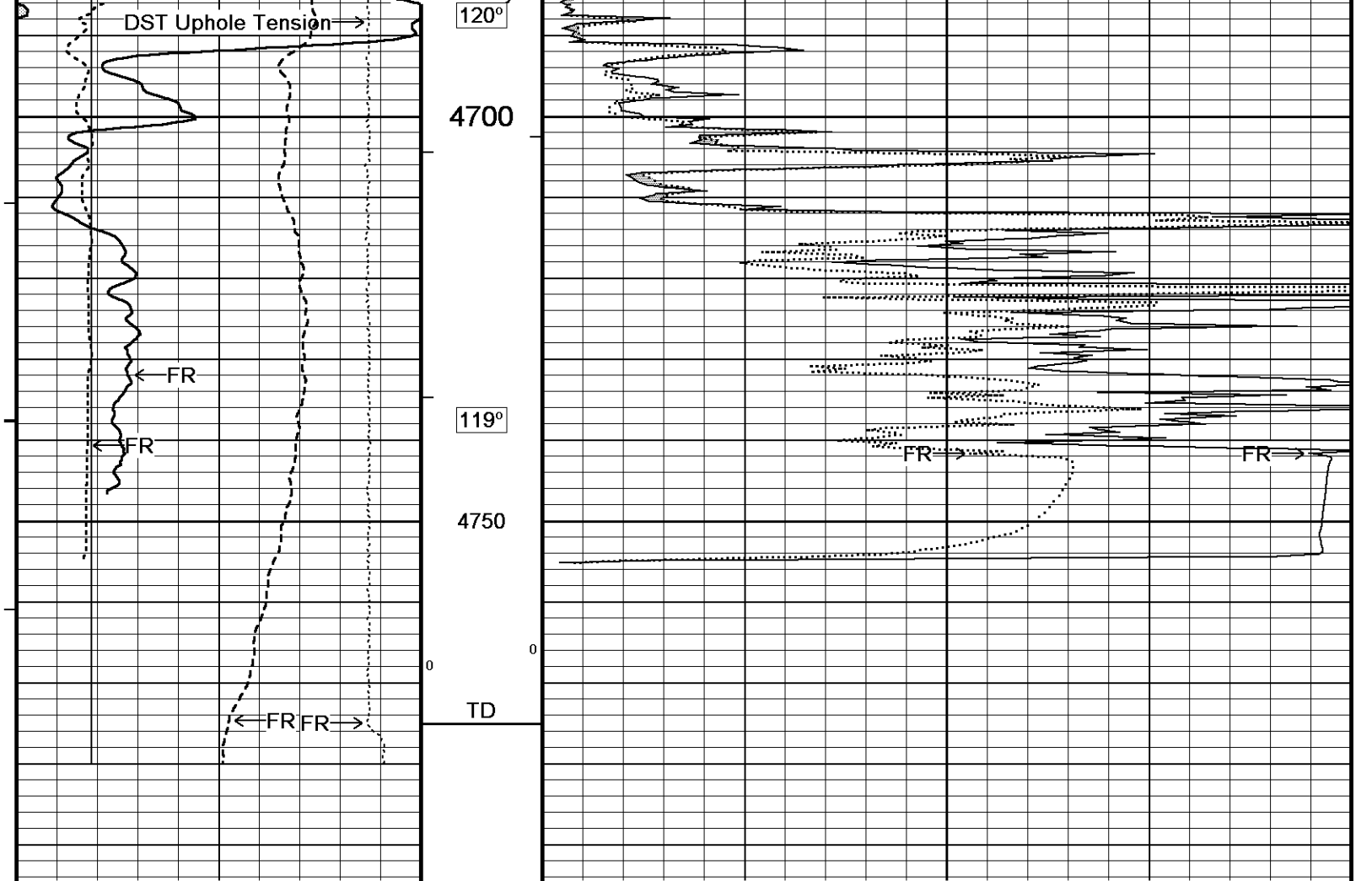

5000 pounds 0
 Replay Scale 1:240

Depth Based Data - Maximum Sampling Increment 10.0cm
 Plotted on 10-DEC-2014 10:26
 Filename: C:\Minimus 14.05\Log Data\Shakespeare Rudolph 1-23\Shakespeare Rudolph 1-23 Main.dta
 Recorded on 10-DEC-2014 08:02
 System Versions: Logged with 14.05.5280 Plotted with 14.05.5280

↑ 5 INCH MAIN ↑

↓ REPEAT SECTION ↓

Depth Based Data - Maximum Sampling Increment 10.0cm
 Plotted on 10-DEC-2014 10:26
 Filename: C:\Minimus 14.05\Log Data\Shakespeare Rudolph ...\Shakespeare Rudolph 1-23 Repeat.dta
 Recorded on 10-DEC-2014 07:45
 System Versions: Logged with 14.05.5280 Plotted with 14.05.5280

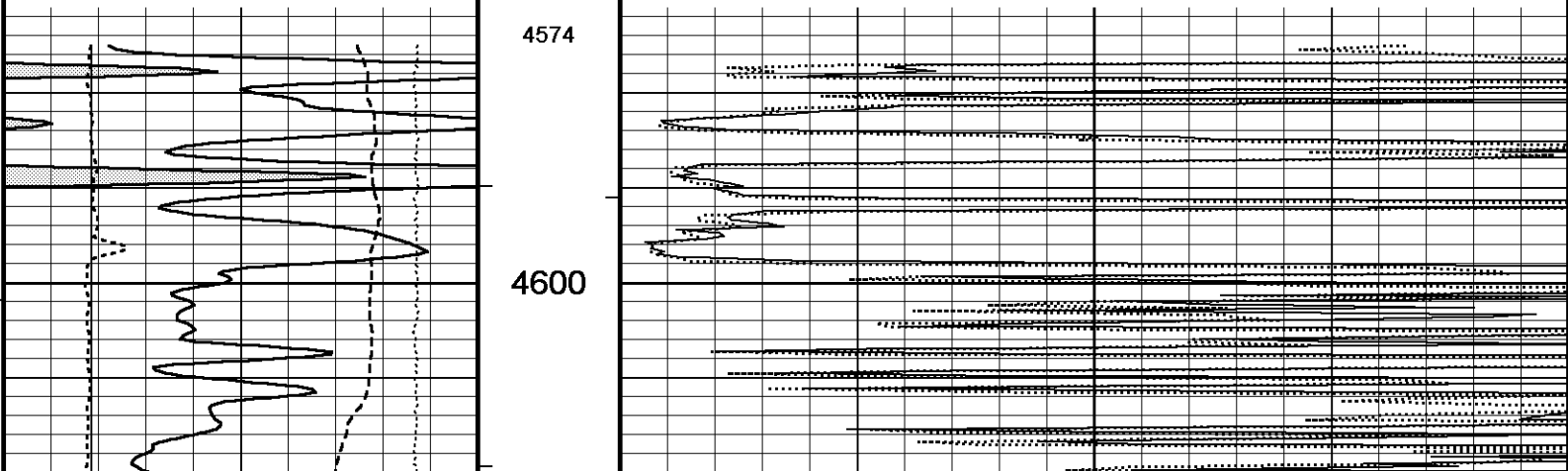
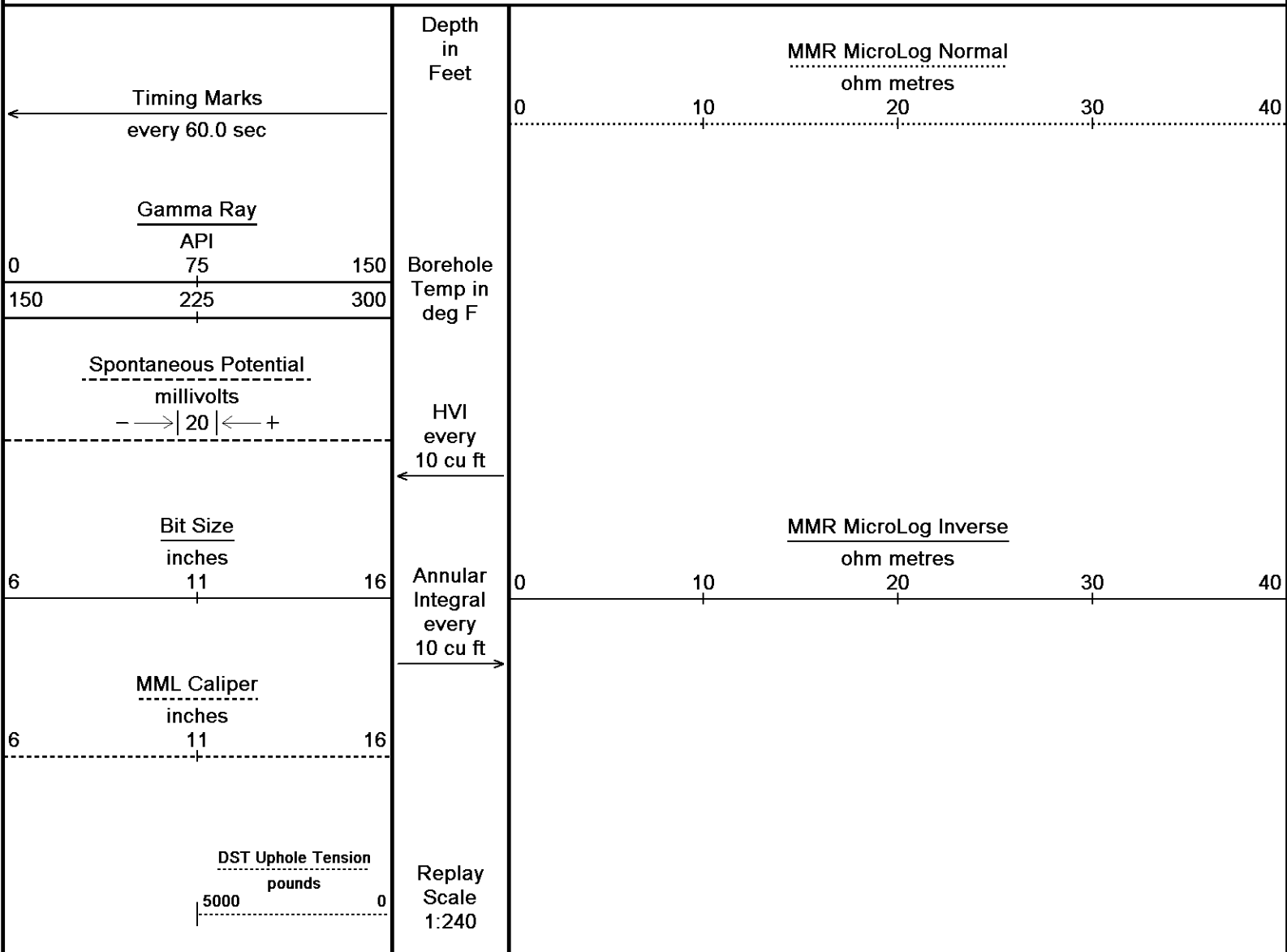

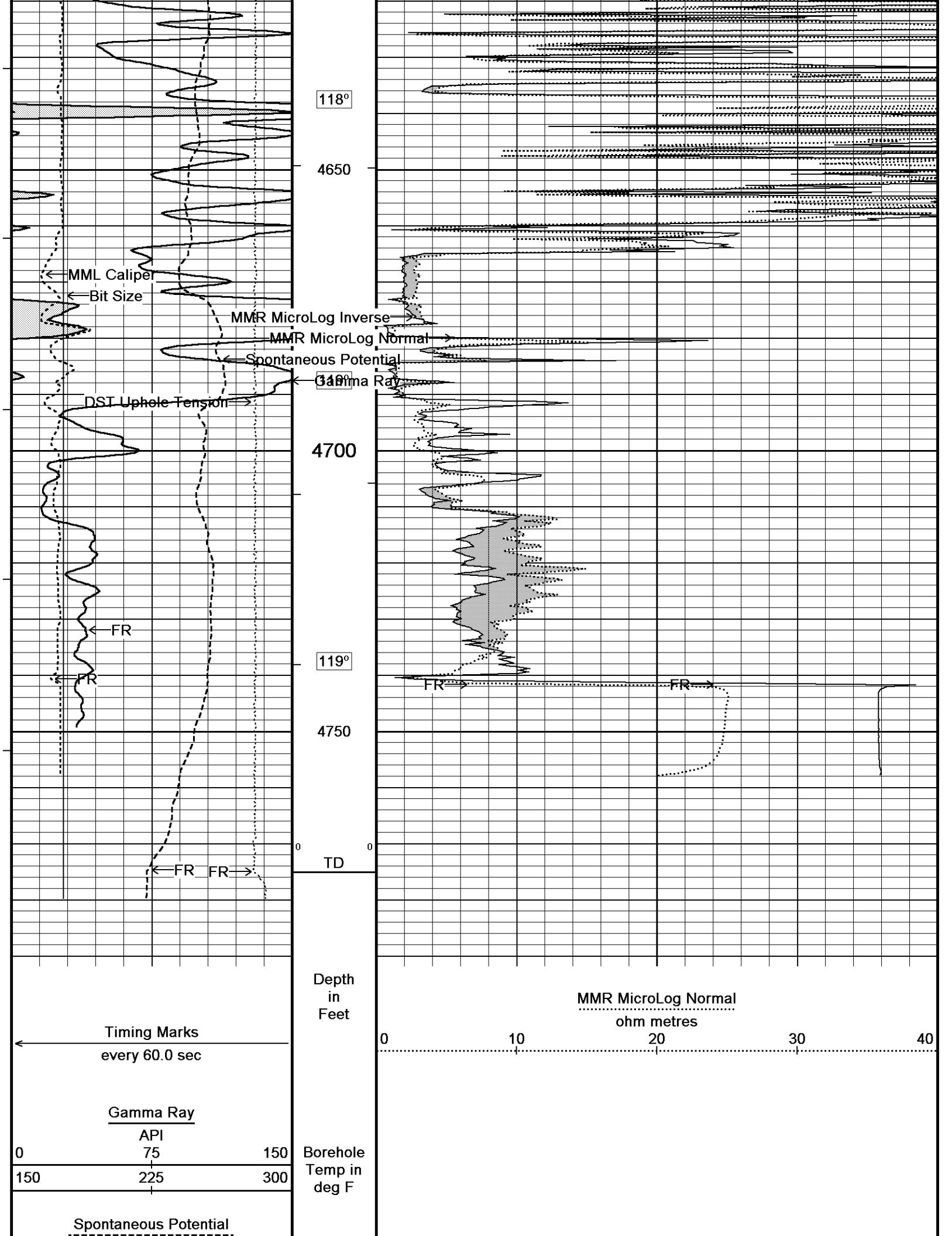

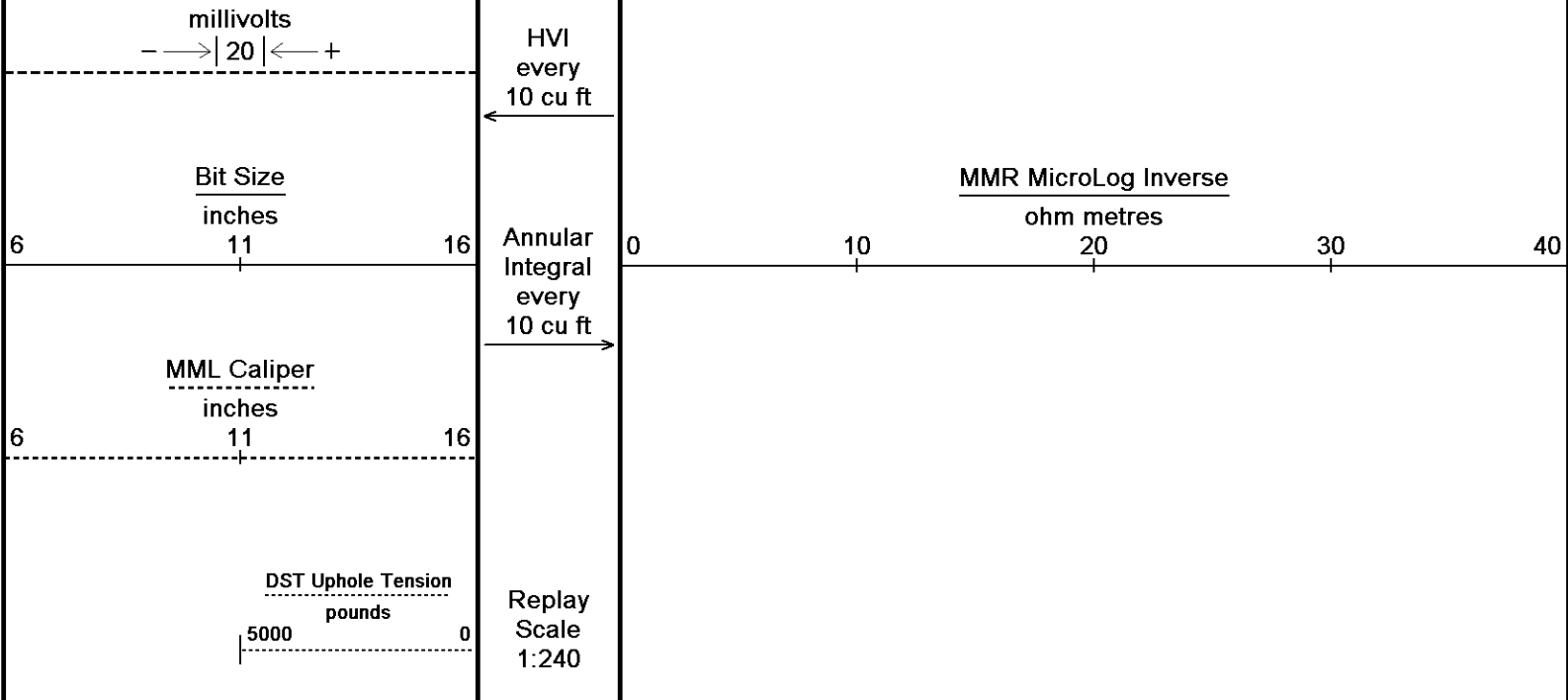

Depth Based Data - Maximum Sampling Increment 10.0cm
 Plotted on 10-DEC-2014 10:26
 Filename: C:\Minimus 14.05\Log Data\Shakespeare Rudolph ...\Shakespeare Rudolph 1-23 Repeat.dta
 Recorded on 10-DEC-2014 07:45
 System Versions: Logged with 14.05.5280 Plotted with 14.05.5280

↑ REPEAT SECTION ↑

BEFORE SURVEY CALIBRATION
 C:\Minimus 14.05\Log Data\Shakespeare Rudolph 1-23\Shakespeare Rudolph 1-23.dta

General Constants All 000 Last Edited on 10-DEC-2014,07:05

General Parameters		
Mud Resistivity	0.598	ohm-metres
Mud Resistivity Temperature	75.000	degrees F
Water Level	0.000	feet
Borehole Fluid Processing	Wet Hole	
Hole/Annular Volume and Differential Caliper Parameters		
HVOL Method	Single Caliper	
HVOL Caliper 1	Density Caliper	
HVOL Caliper 2	N/A	
Annular Volume Diameter	5.500	inches
Caliper for Differential Caliper	Density Caliper	
Rwa Parameters		
Porosity used	Crossplot Porosity	
Resistivity used	Array Ind. One Res Rt	
RWA Constant A	0.610	
RWA Constant M	2.150	
SW/APOR Tool Source	0.000	

Down-hole Tension Calibration SMS 0 Field Calibration on 10-DEC-2014 06:54

Reading No	Measured	Calibrated (lbs)
1	14625.10	0.00
2	15498.90	393.00

High Resolution Temperature Calibration MCG-B 39 Field Calibration on 24-NOV-2014,12:05

	Measured	Calibrated(Deg F)
Lower	10.00	10.00
Upper	100.00	100.00

High Resolution Temperature Constants MCG-B 39 Last Edited on 28-AUG-2014,01:02

Pre-filter Length	11
-------------------	----

	Measured	Calibrated (mV)
Reference 1	102.6	99.9
Reference 2	-97.9	-100.0

Gamma Calibration MCG-B 39

Field Calibration on 09-DEC-2014 16:20

	Measured	Calibrated (API)
Background	78	53
Calibrator (Gross)	1146	778
Calibrator (Net)	1069	725

Gamma Calibration Tolerances MCG-B 39

Ratio	1.474	<input type="text" value="1.40"/>	<input type="text" value="1.475"/>	<input type="text" value="1.55"/>	Counts/API
-------	-------	-----------------------------------	------------------------------------	-----------------------------------	------------

Gamma Constants MCG-B 39

Last Edited on 10-DEC-2014,03:21

Gamma Calibrator Number	GRC038	
GRC-M Calibrator Jig in Use?	NO	
Inactive Background Jig in Use?	NO	
Mud Density	1.10	gm/cc
Caliper Source for Processing	Density Caliper	
Tool Position	Eccentred	
Concentration of KCl		kppm
K Mud Type	Chloride	
K Mud Concentration	0.00	%

Micro Normal and Micro Inverse Calibration MML-A 3

Base Calibration on 01-DEC-2014 10:30

Field Check on 09-DEC-2014 16:40

Base Calibration		Measured		Calibrated (ohm-m)	
Channel	Resistor 1	Resistor 2	Resistor 1	Resistor 2	
Micro Normal	10.0	49.9	5.1	25.6	
Micro Inverse	10.0	49.9	3.4	16.9	

Channel	Base Check (ohm-m)	Field Check (ohm-m)
Micro Normal	77.4	77.4
Micro Inverse	51.3	51.3

Micro Normal & Micro Inverse Calibration Tolerance MML-A 3

Micro Normal Res. 1	10.0	<input type="text" value="10.0"/>	ohm	Micro Normal Res. 2	49.9	<input type="text" value="49.9"/>	ohm
Micro Inverse Res. 1	10.0	<input type="text" value="10.0"/>	ohm	Micro Inverse Res. 2	49.9	<input type="text" value="49.9"/>	ohm
Micro Normal Base Check	77.4	<input type="text" value="77.26"/>	ohm-m				
Micro Inverse Base Check	51.3	<input type="text" value="51.18"/>	ohm-m				
Micro Normal Field Check	77.4	<input type="text" value="77.4"/>	ohm-m				
Micro Inverse Field Check	51.3	<input type="text" value="51.3"/>	ohm-m				

Micro Normal and Micro Inverse Constants MML-A 3

Last Edited on 09-DEC-2014,16:38

Pad Type	8-12 in Soft Rubber Inflatable 006-9011-159	
Micro Normal K Factor	0.5110	
Micro Inverse K Factor	0.3380	
Standoff Offset	N/A	inches

Caliper Calibration MML-A 3

Base Calibration on 01-DEC-2014 10:40

Field Calibration on 09-DEC-2014 16:38

Base Calibration		Measured	Calibrator Size (in)
Reading No			
1		15291	5.98
2		18492	7.97
3		21784	9.86
4		25739	11.92
5		0	0.00
6		N/A	N/A

Field Calibration

Measured Caliper (in)
7.96

Actual Caliper (in)
7.97

Caliper Calibration Tolerances MML-A 3

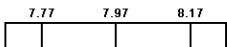
Short Arm Field Cal. 7.96  in

Neutron Calibration MDN-A.B 152

Base Calibration on 09-DEC-2014 15:34
Field Check on 09-DEC-2014 15:59

Base Calibration

	Measured		Calibrated (cps)	
	Near	Far	Near	Far
Ratio	2888	88	3714	110
	32.811		33.764	

Field Calibrator at Base

	Calibrated (cps)
Ratio	1761 2584
	0.681

Field Check

	Calibrated (cps)
Ratio	1761 2586
	0.681

Neutron Calibration Tolerances MDN-A.B 152

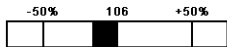
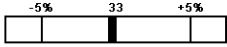
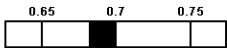
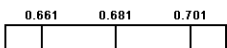
Near Reading	2888		cps	Far Reading	88		cps
Ratio	32.811						
Base Check	0.681						
Field Check	0.681						

Neutron Constants MDN-A.B 152

Last Edited on 10-DEC-2014,03:21

Neutron Source Id	P0204NN	
Neutron Jig Number	5824NE	
Air Hole Processing	Legacy	
Caliper Source for Processing	Density Caliper	
Stand-off	0.00	inches
Mud Density	1.00	gm/cc
Limestone Sigma	7.10	cu
Sandstone Sigma	4.26	cu
Dolomite Sigma	4.70	cu
Formation Pressure Source	None	
Formation Pressure	N/A	kpsi
Temperature Source	Constant Value	
Temperature	68.00	degrees F
Mud Salinity	0.00	kppm
Salinity Correction	Not Applied	
Formation Fluid Salinity Source	None	
Formation Fluid Salinity	N/A	kppm
Barite Mud Correction	Not Applied	

FE Calibration MFE-B.J 353

Base Calibration on 01-DEC-2014 10:12
Field Check on 09-DEC-2014 16:35

Base Calibration

	Measured	Calibrated (ohm-m)
Reference 1	0.0	0.0
Reference 2	975.8	126.8

Base Check 277.9

Field Check 277.8

FE Calibration Tolerances MFE-B.J 353

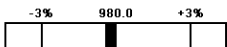
Reference 2 975.8  ohm

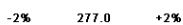

Base Check 277.9  ohm-m

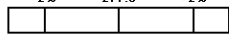
Field Check 277.8  ohm-m

FE Constants MFE-B.J 353

Last Edited on 10-DEC-2014,03:20

Running Mode No Sleeve
MFE K Factor 0.1268
Caliper Source for FE correction Density Caliper
Caliper Value for FE correction N/A inches
Rm Source for FE correction MCG External Temperature Corrected
Temp. for Rm Corr. MCG External Temperature
Stand-off 0.5 inches

High Resolution Temperature Calibration MAI-A.A 111

Field Calibration on 24-NOV-2014,10:23

	Measured	Calibrated(Deg F)
Lower	10.00	10.00
Upper	100.00	100.00

High Resolution Temperature Constants MAI-A.A 111

Last Edited on 26-JUN-2014,15:06

Pre-filter Length 11

Induction Calibration MAI-A.A 111

Base Calibration on 05-AUG-2014,09:34
Field Check on 09-DEC-2014 16:33

Base Calibration



Test Loop Calibration Channel	Measured		Calibrated (mmho/m)	
	Low	High	Low	High
1	17.6	473.6	9.3	966.2
2	6.4	385.9	7.6	821.4
3	3.2	264.0	5.2	566.0
4	2.1	135.5	2.6	279.2

Array Temperature 23.0 Deg F

Test Loop Calibration Verified

Channel	Base Check (mmho/m)		Field Check (mmho/m)		
	Low	High	Low	High	
1	0.0	0.0	11.9	3872.3	
2	0.0	0.0	29.7	3527.5	
3	0.0	0.0	29.0	3020.8	
4	0.0	0.0	19.1	2058.0	
Deep			17.7	1961.6	
Medium			43.1	3975.9	
Shallow			44.3	5232.1	
Array Temperature		0.0		61.6	Deg F

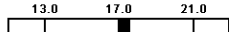
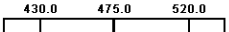
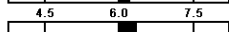
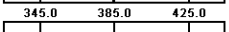
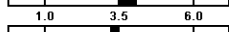
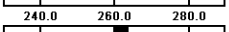
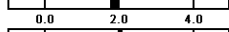
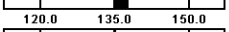
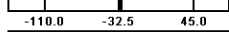
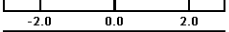
Induction Calibration Tolerances MAI-A.A 111

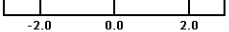
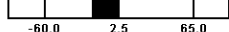
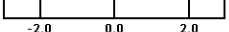
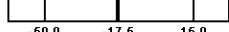
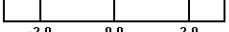
Low Conductivity 1	17.6		mmho/m	High Conductivity 1	473.6		mmho/m
Low Conductivity 2	6.4		mmho/m	High Conductivity 2	385.9		mmho/m
Low Conductivity 3	3.2		mmho/m	High Conductivity 3	264.0		mmho/m
Low Conductivity 4	2.1		mmho/m	High Conductivity 4	135.5		mmho/m
Background Vx 1	0.0		mmho/m	Phase Check Loop 1	0.0		%
Background Vx 2	0.0		mmho/m	Phase Check Loop 2	0.0		%
Background Vx 3	0.0		mmho/m	Phase Check Loop 3	0.0		%
Background Vx 4	0.0		mmho/m	Phase Check Loop 4	0.0		%

Induction Constants MAI-A.A 111

Last Edited on 10-DEC-2014,03:19

Induction Model RtAP-WBM
Caliper for Borehole Corr. Density Caliper
Hole Size for Borehole Correction N/A inches
Tool Centred No
Stand-off Type Fins
Stand-off 0.50 inches

Number of Fins on Stand-off	8.0000	mmhos
Stand-off Fin Angle	45.00	degrees
Stand-off Fin Width	0.5000	inches
Borehole Corr. Rm Slope Value: Temperature Corrected		
Temp. for Rm Corr.	MCG External Temperature	
Squasher Start	0.0020	mhos/metre
Squasher Offset	N/A	mhos/metre

Borehole Normalisation			
DRM1	0.0000	DRC1	0.0000
DRM2	0.0000	DRC2	0.0000
MRM1	0.0000	MRC1	0.0000
MRM2	0.0000	MRC2	0.0000
SRM1	0.0000	SRC1	0.0000
SRM2	0.0000	SRC2	0.0000

Calibration Site Corrections			
Channel 1	0.00	mmhos/metre	
Channel 2	0.00	mmhos/metre	
Channel 3	0.00	mmhos/metre	
Channel 4	0.00	mmhos/metre	

Apparent Porosity and Water Saturation Constants			
Archie Constant (A)	1.00		
Cementation Exponent (M)	2.00		
Saturation Exponent (N)	2.00		
Saturation of Water for Apor	100.00	percent	
Resistivity of Water for Apor and Sw	0.05	ohm-m	
Resistivity of Mud Filtrate for Sw	0.00	ohm-m	
Source for Rt	0.00		
Source for Rxo	0.00		

Caliper Calibration MPD-C.A 216

Base Calibration on 09-DEC-2014 13:29
Field Calibration on 09-DEC-2014 13:33

Base Calibration			
Reading No	Measured	Calibrator Size (in)	
1	19120	3.99	
2	29184	5.98	
3	39328	7.97	
4	49072	9.86	
5	60273	11.92	
6	N/A	N/A	

Field Calibration			
	Measured Caliper (in)	Actual Caliper (in)	
	7.97	7.97	

Caliper Calibration Tolerances MPD-C.A 216

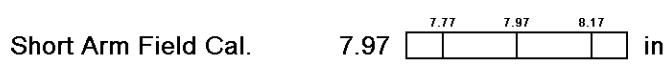

Photo Density Calibration MPD-C.A 216

Base Calibration on 09-DEC-2014 13:48
Field Check on 09-DEC-2014 13:54

Density Calibration				
Base Calibration		Measured		Calibrated (sdu)
	Near	Far	Near	Far
Background	1092	1289		
Reference 1	58913	30669	59556	30836
Reference 2	24800	2733	24941	2541

Field Check at Base			
	1091.9	1288.6	

Field Check			
	1102.4	1312.8	

PE Calibration				
Base Calibration		Measured		Calibrated
	WS	WH	Ratio	Ratio
Background	200	972		
Reference 1	24229	58725	0.416	0.371

Reference 1	24229	38723	0.418	0.371
Reference 2	6999	24668	0.287	0.272

Field Check at Base

200.5 971.7

Field Check

200.8 980.3

Photo Density Calibration Tolerances MPD-C.A 216

Near Density Ratio 2.44 

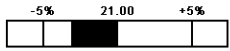
Far Density Ratio 20.34 

PE Calibration 0.120 

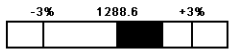
Far Den. Field Check 1312.8 

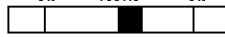
Near Den. Field Check 1102.4 

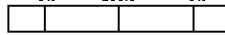
PE WS Field Check 200.8 

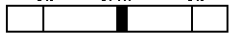
PE WH Field Check 980.3 

Density Constants MPD-C.A 216

Last Edited on 10-DEC-2014,03:21

Density Source Id	18235B	
Nylon Calibrator Number	DNCE695	
Aluminium Calibrator Number	DACD698	
Density Shoe Profile	8 inch	
Caliper Source for Processing	Density Caliper	
PE Correction to Density	Not Applied	
Mud Density	1.10	gm/cc
Mud Density Z/A Multiplier	1.11	
Mud Filtrate Density	1.00	gm/cc
Dry Hole Mud Filtrate Density	1.00	gm/cc
DNCT	0.00	gm/cc
CRCT	0.00	gm/cc
Density Z/A Correction	Hybrid	

Matrix Density (gm/cc)	Depth (ft)
2.71	0.00
0.00	0.00
0.00	0.00
0.00	0.00
0.00	0.00
0.00	0.00
0.00	0.00
0.00	0.00
0.00	0.00
0.00	0.00

DOWNHOLE EQUIPMENT

C:\Minimus 14.05\Log Data\Shakespeare Rudolph 1-23\Shakespeare Rudolph 1-23.dta

3/8" Triple Cone Cable Head (MCB C A)
MCB-C.A 233 LG: 1.58 ft WT: 15.4 lb OD: 2.240 in

Compact Comms Gamma
MCG-B 39 LG: 8.70 ft WT: 63.9 lb OD: 2.244 in

Compact Micro-log
MML-A 3 LG: 7.97 ft WT: 81.6 lb OD: 2.240 in

Compact Neutron
MDN-A.B 152 LG: 5.04 ft WT: 50.7 lb OD: 2.244 in

Compact Density/Caliper
MPD-C.A 216 LG: 9.59 ft WT: 90.4 lb OD: 2.449 in

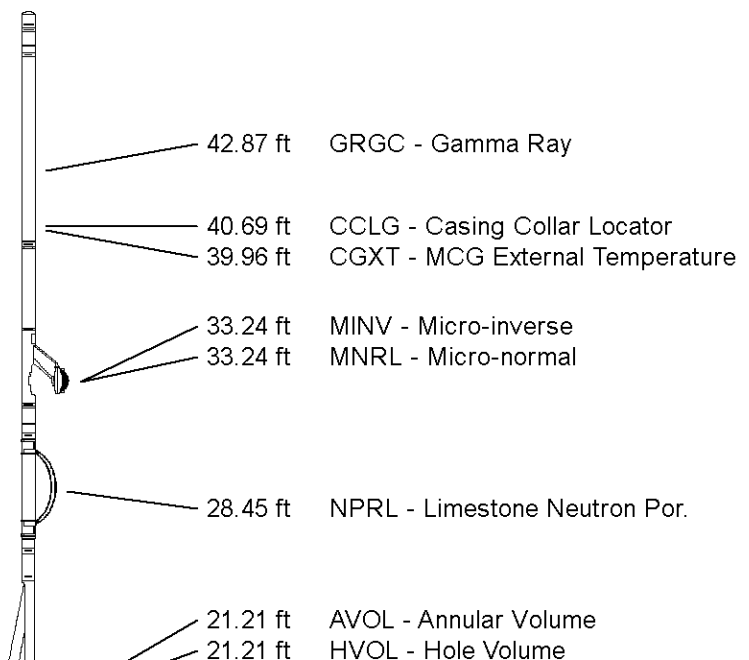

Compact Focussed Electric
 MFE-B.J 353 LG: 6.05 ft WT: 48.5 lb OD: 2.244 in

Compact Induction
 MAI-A.A 111 LG: 10.81 ft WT: 48.5 lb OD: 2.244 in

Total Length: 49.73 ft Weight: 399.0 lb

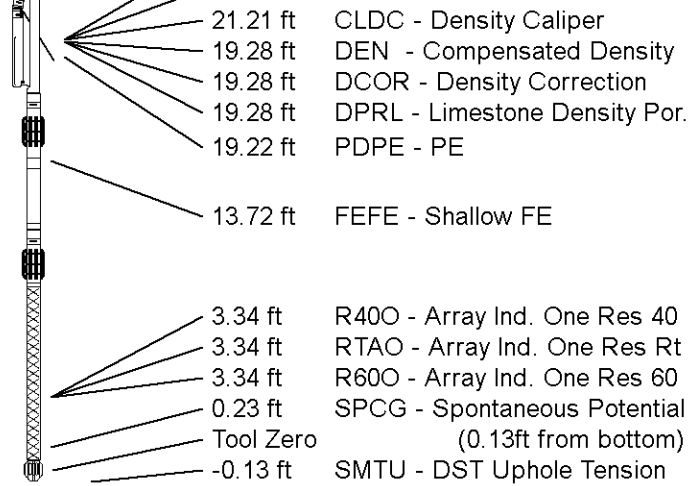

COMPANY SHAKESPEARE OIL CO., INC.
 WELL RUDOLPH 1-23
 FIELD WILDCAT
 PROVINCE/COUNTY SCOTT
 COUNTRY/STATE U.S.A. / KANSAS

Elevation Kelly Bushing	3026.00	feet	First Reading	4741.76	feet
Elevation Drill Floor	3024.00	feet	Depth Driller	4770.00	feet
Elevation Ground Level	3016.00	feet	Depth Logger	4775.00	feet



Weatherford[®]

MICRORESISTIVITY LOG