



**Weatherford**

**COMPACT PHOTO DENSITY  
COMPENSATED NEUTRON  
MICRORESISTIVITY LOG**

COMPANY	MCCOY PETROLEUM CORPORATION		
WELL	UMCC 'A' #2-17		
FIELD	WILDCAT		
PROVINCE/COUNTY	MEADE		
COUNTRY/STATE	U.S.A. / KANSAS		
LOCATION	660' FSL & 1980' FWL		
SEC 17	TWP 30S	RGE 30W	Other Services
Latitude	MAI/MFE		
Longitude			
API Number	15-119-21379		
Permanent Datum GL, Elevation	2819 feet		
Log Measured From	KB		
Drilling Measured From	KB @ 11 FEET		
Date	31-OCT-2014		Elevations: KB 2830.00 DF 2828.00 GL 2819.00
Run Number	ONE		
Service Order	4558-101987382		
Depth Driller	5700.00	feet	
Depth Logger	5700.00	feet	
First Reading	5681.00	feet	
Last Reading	4000.00	feet	
Casing Driller	1828.00	feet	
Casing Logger	1829.00	feet	
Bit Size	7.875	inches	
Hole Fluid Type	CHEMICAL		
Density / Viscosity	9.20 lb/USg	48.00 CP	
PH / Fluid Loss	10.00	8.80 ml/30Min	
Sample Source	FLOWLINE		
Rm @ Measured Temp	0.98 @ 86.0	ohm-m	
Rmf @ Measured Temp	0.78 @ 86.0	ohm-m	
Rmc @ Measured Temp	1.18 @ 86.0	ohm-m	
Source Rmf / Rmc	CALC	CALC	
Rm @ BHT	0.69 @ 122.0	ohm-m	
Time Since Circulation	5 HOURS		
Max Recorded Temp	122.00	deg F	
Equipment / Base	13244	LIB	
Recorded By	ADAM SILL		
Witnessed By	DAVE WILLIAMS		
JOB #	LB14-341		

**BOREHOLE RECORD**

Last Edited: 31-OCT-2014 21:49

Bit Size inches	Depth From feet	Depth To feet
7.875	1828.00	5700.00

**CASING RECORD**

Type	Size inches	Depth From feet	Shoe Depth feet	Weight pounds/ft
SURFACE	8.625	0.00	1828.00	24.00

**REMARKS**

- SOFTWARE ISSUE: WLS 14.03.4558.
- RUN ONE: MCG, MML, MDN, MPD, MFE, MAI RUN IN COMBINATION.
  - HARDWARE: DUAL BOWSPRING USED ON MDN.
  - 0.5 INCH STANDOFF USED ON MFE.
  - 0.5 INCH STANDOFF USED ON MAI.
- 2.71 G/CC LIMESTONE DENSITY MATRIX USED TO CALCULATE POROSITY.
- BOREHOLE RUGOSITY, TIGHT PULLS, AND WASHOUTS WILL AFFECT DATA QUALITY.
- ALL INTERVALS LOGGED AND SCALED PER CUSTOMER'S REQUEST.
- TOTAL HOLE VOLUME FROM TD TO SURFACE CASING: 1332 CU.FT.
- ANNULAR HOLE VOLUME WITH 5.5 INCH PRODUCTION CASING FROM TD TO 4000 FEET: 277 CU.FT.
- RIG: STERLING #2

RIS: OPERING #2.

- ENGINEER: A. SILL.

- OPERATOR: J. DUNLAP, N. ADAME.

In interpreting, communicating or providing information and/or making recommendations, either written or oral, as to logs or test or other data, type or amount of material, or Work or other service to be furnished, or manner of performance, or in predicting results to be obtained, the Contractor will give the Company the benefit of the Contractor's best judgment based on its experience and will perform all such Work in a good and workmanlike manner. Any interpretation of test or other data, and any recommendation or reservoir description based upon such interpretations, are opinions based upon inferences from measurements and empirical relationships and assumptions, which inferences and assumptions are not infallible, and with respect to which professional engineers and analysts may differ. ACCORDINGLY ANY INTERPRETATION OR RECOMMENDATION RESULTING FROM THE SERVICES WILL BE AT THE SOLE RISK OF THE COMPANY, AND THE CONTRACTOR CANNOT AND DOES NOT WARRANT THE ACCURACY, CORRECTNESS OR COMPLETENESS OF ANY SUCH INTERPRETATION OR RECOMMENDATION, WHICH INTERPRETATIONS AND RECOMMENDATIONS SHOULD NOT, THEREFORE, UNDER ANY CIRCUMSTANCES BE RELIED UPON AS THE SOLE OR MAIN BASIS FOR ANY DRILLING, COMPLETION, WELL TREATMENT, PRODUCTION OR FINANCIAL DECISION, OR ANY PROCEDURE INVOLVING ANY RISK TO THE SAFETY OF ANY DRILLING ACTIVITY, DRILLING RIG OR ITS CREW OR ANY OTHER INDIVIDUAL. THE COMPANY HAS FULL RESPONSIBILITY FOR ALL DECISIONS CONCERNING THE SERVICES.

**5 INCH MAIN**

Depth Based Data - Maximum Sampling Increment 10.0cm Plotted on 01-NOV-2014 04:56  
 Filename: C:\Minimus 14.03.4558\Logs\McCoy UMCC 'A' #2-17\McCoy UMCC 'A' #2-17\_004.dta Recorded on 01-NOV-2014 02:34  
 System Versions: Logged with 14.03.4558 Processed with 14.03.4558 Plotted with 14.03.4558

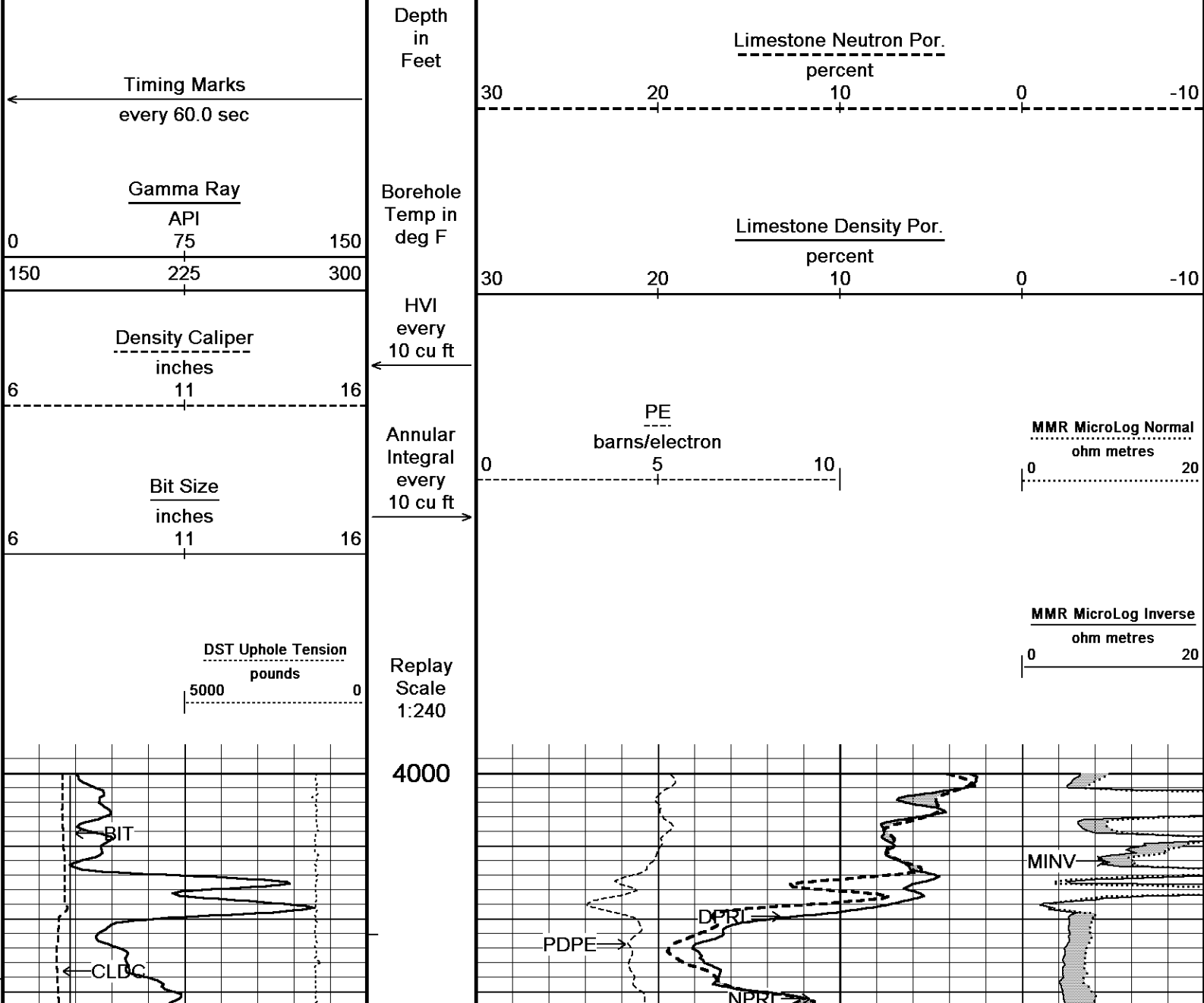

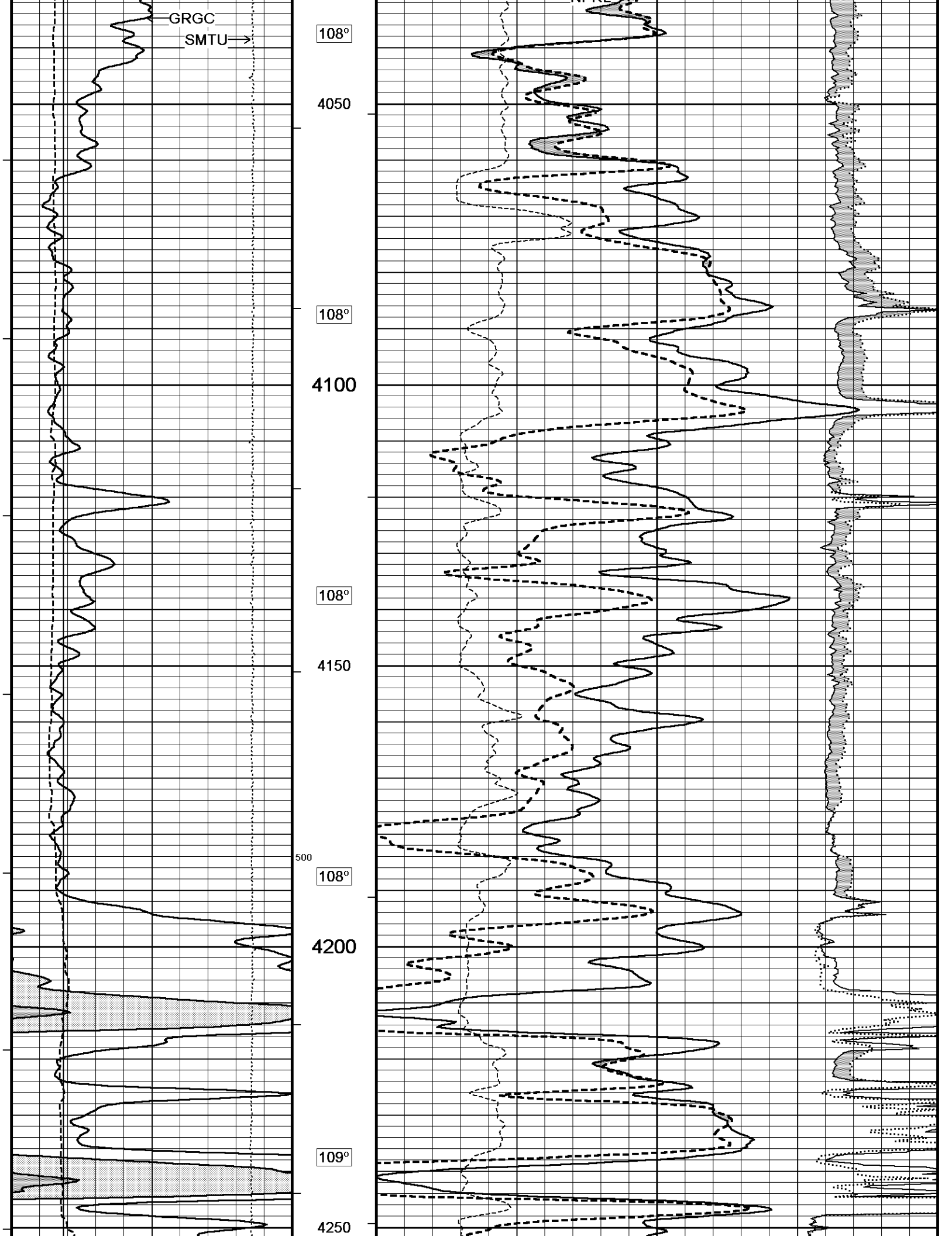

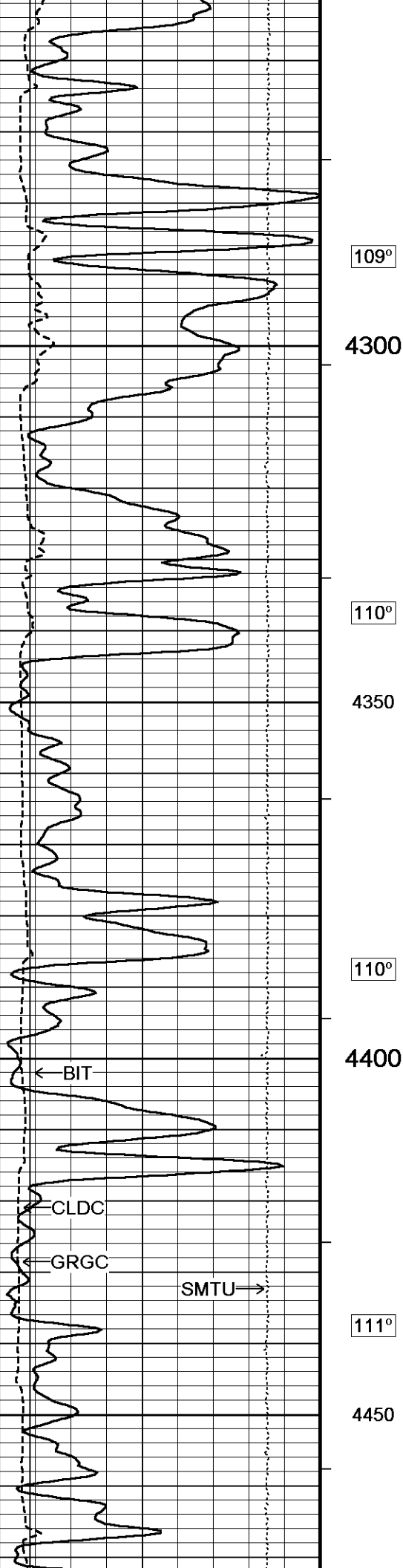

109°

4300

110°

4350

110°

4400

111°

4450

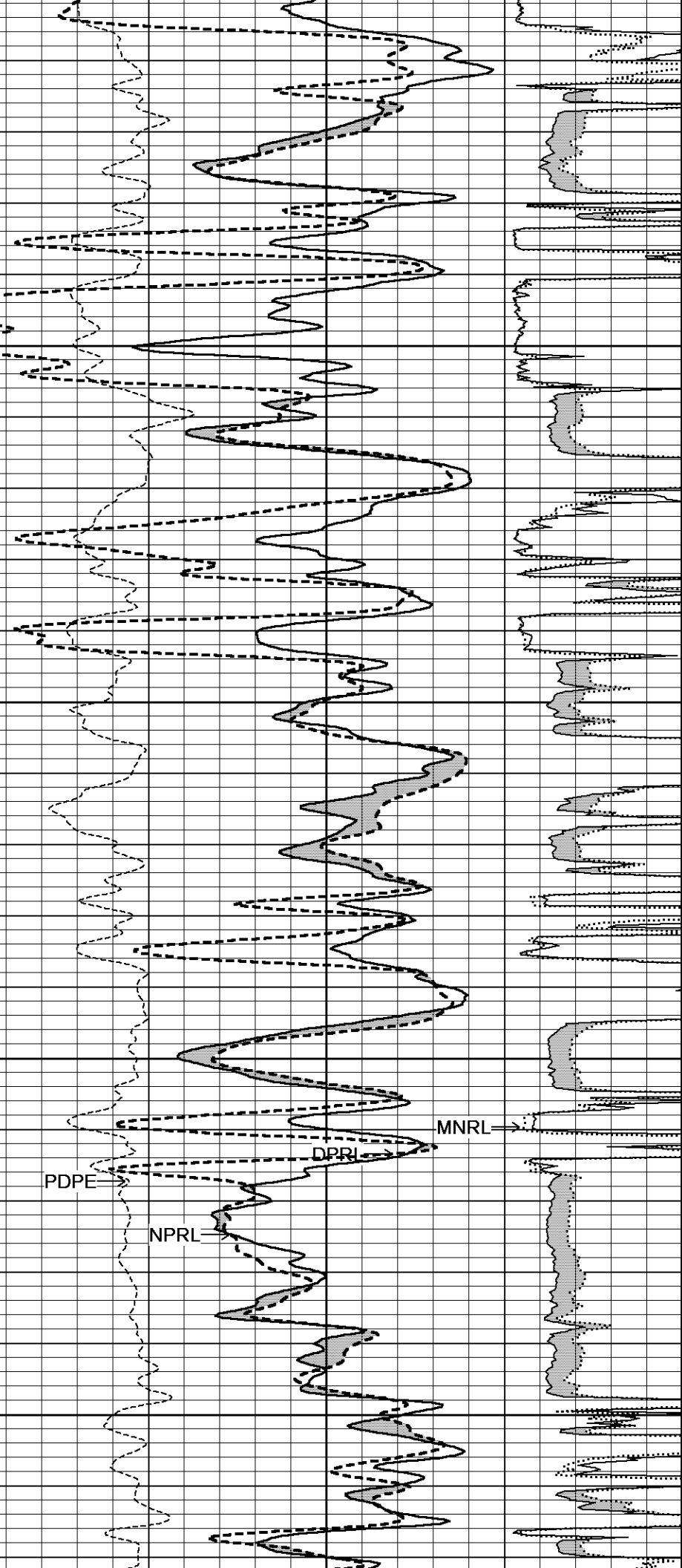

PDPE

NPRL

DPRL

MNRL

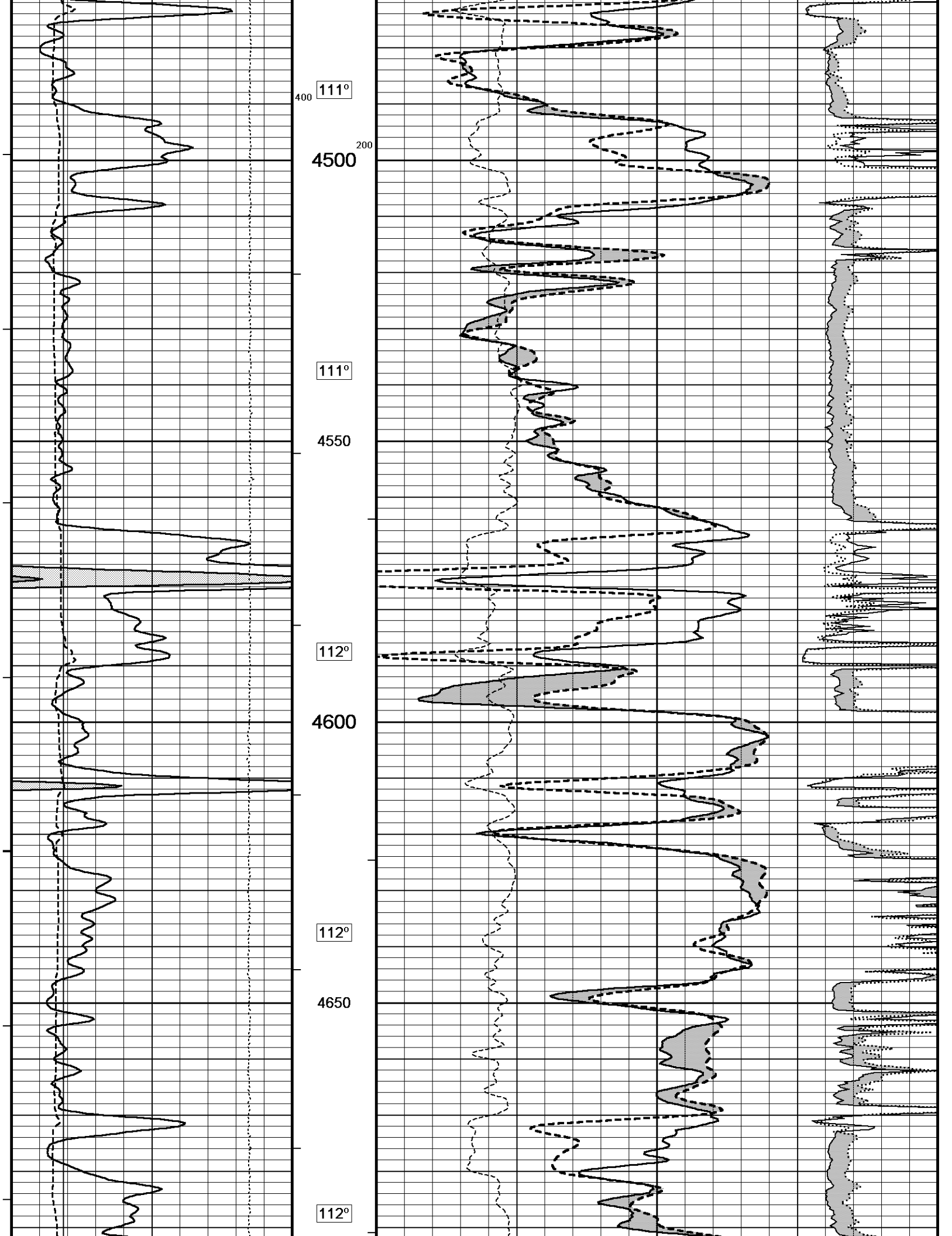

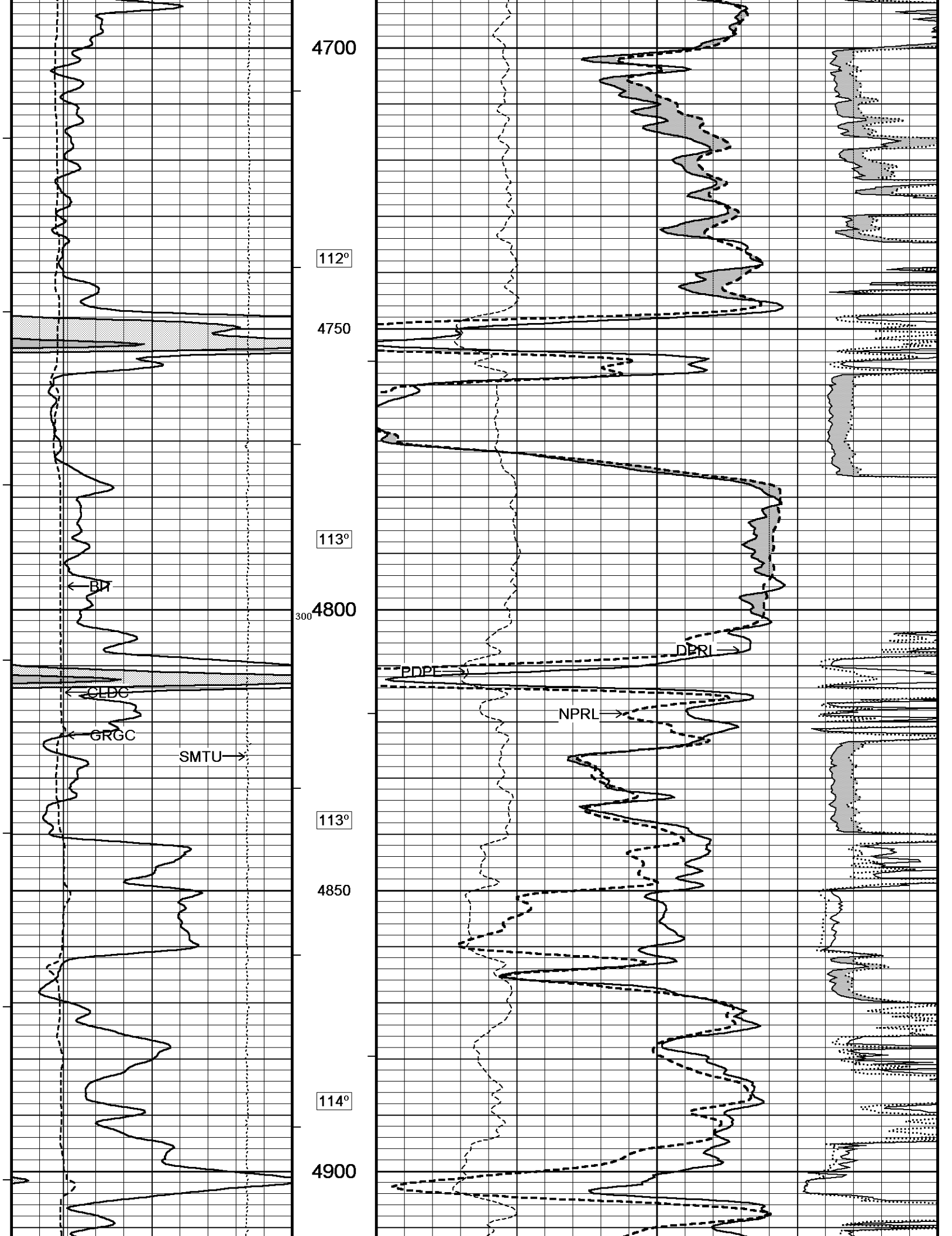

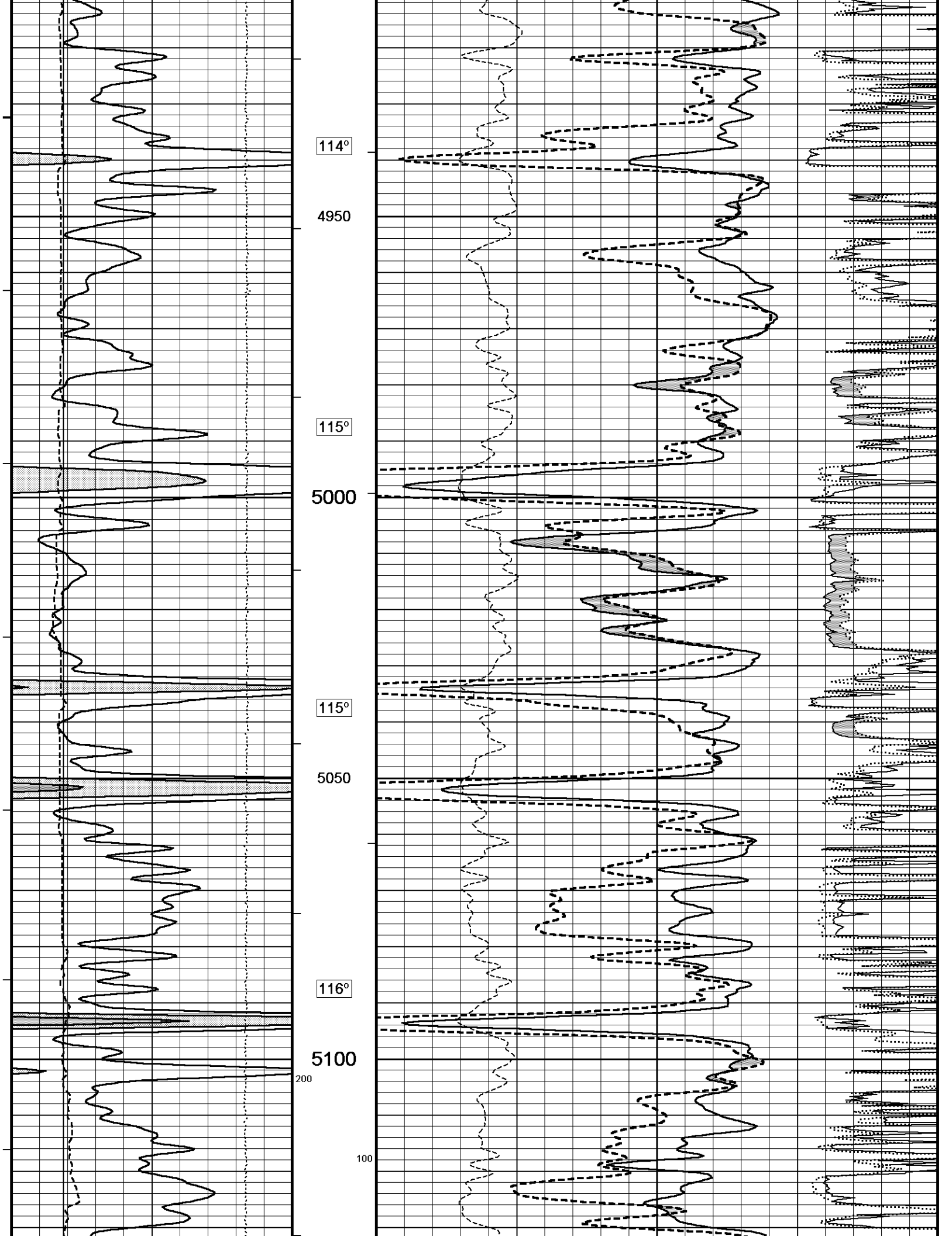

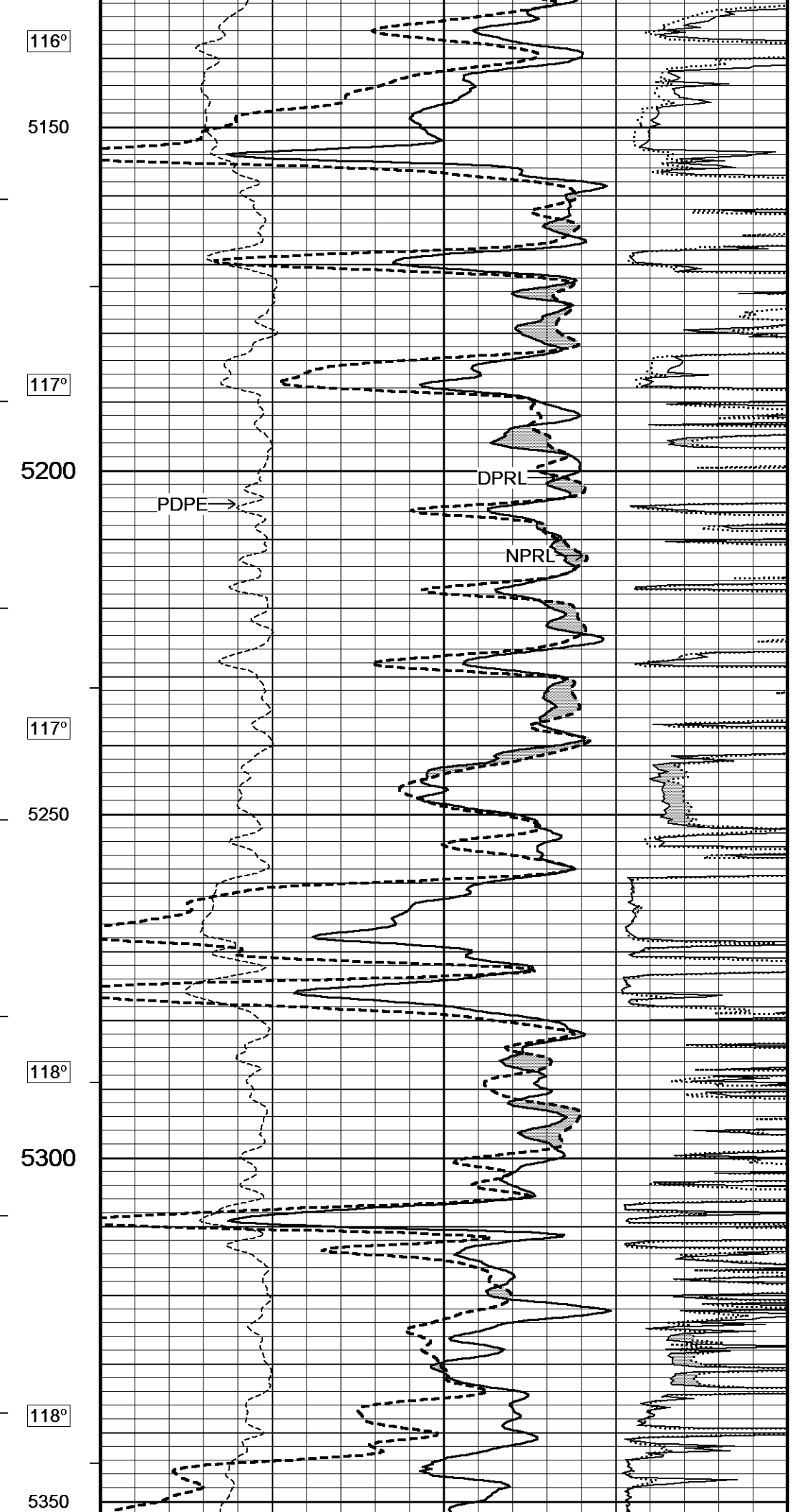
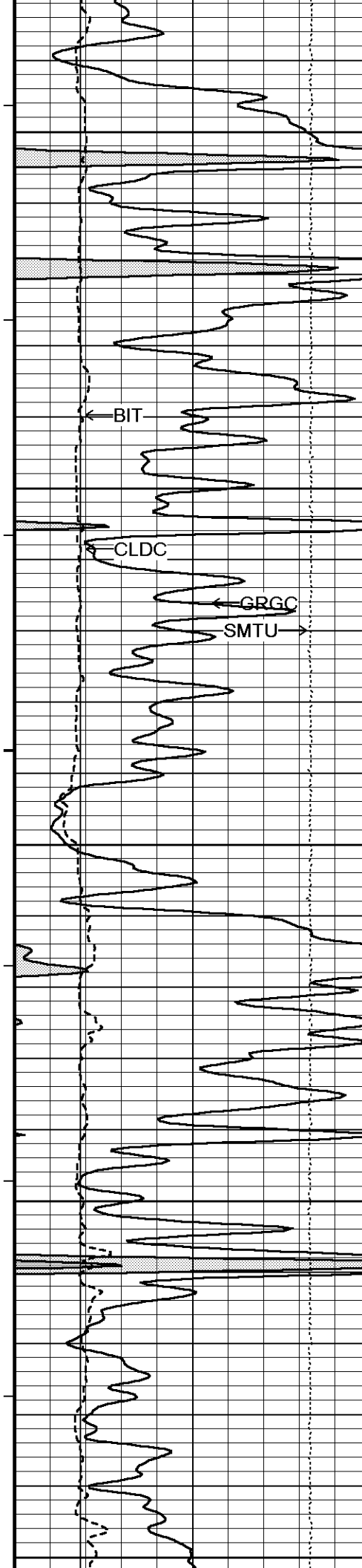

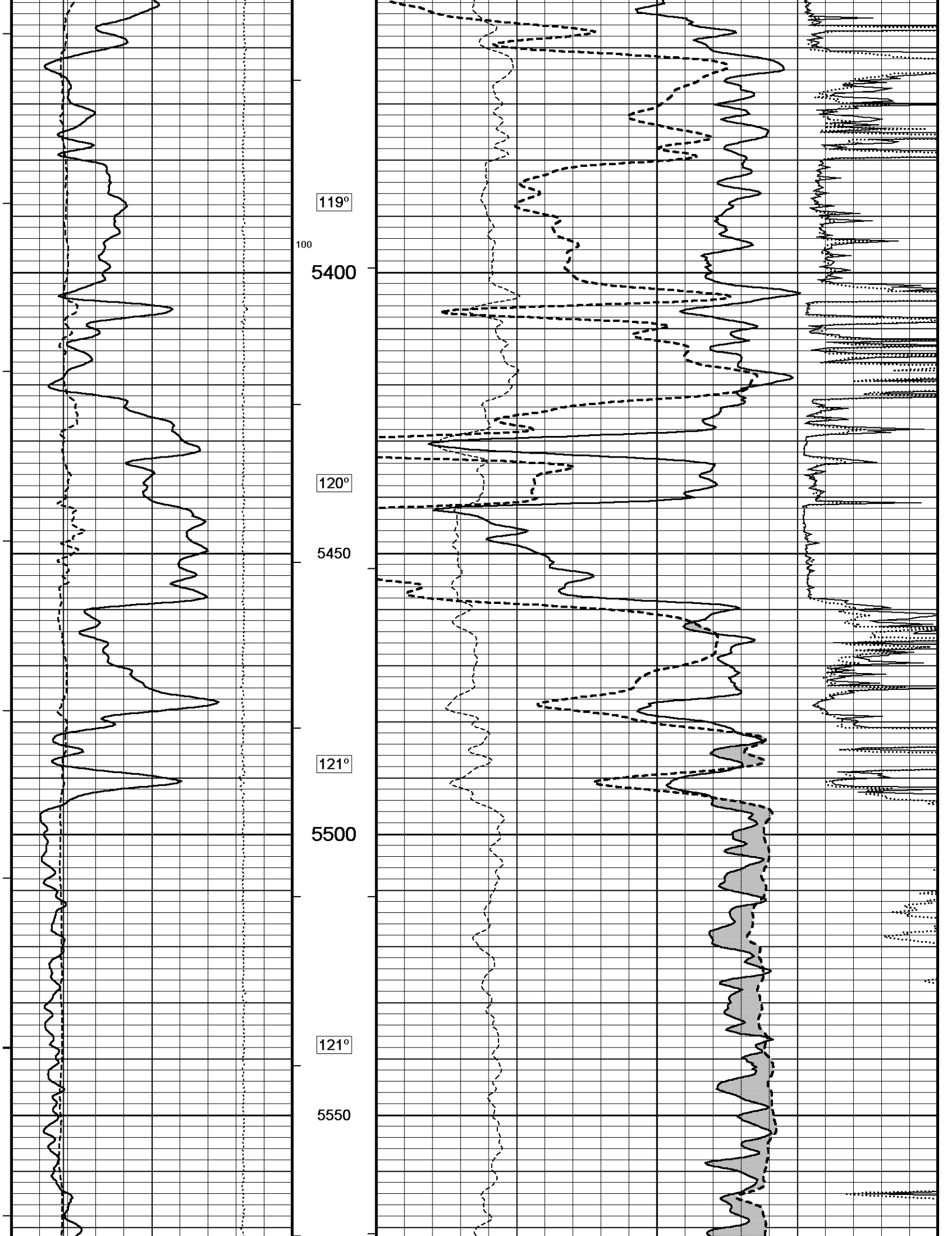

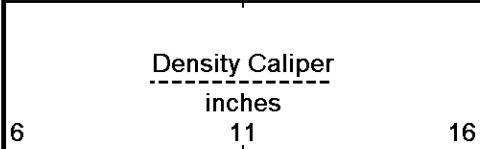
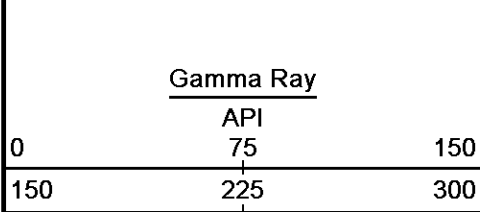
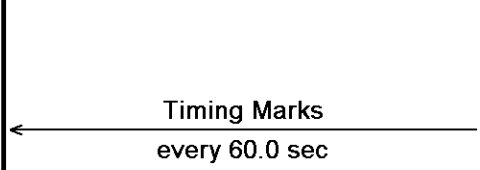
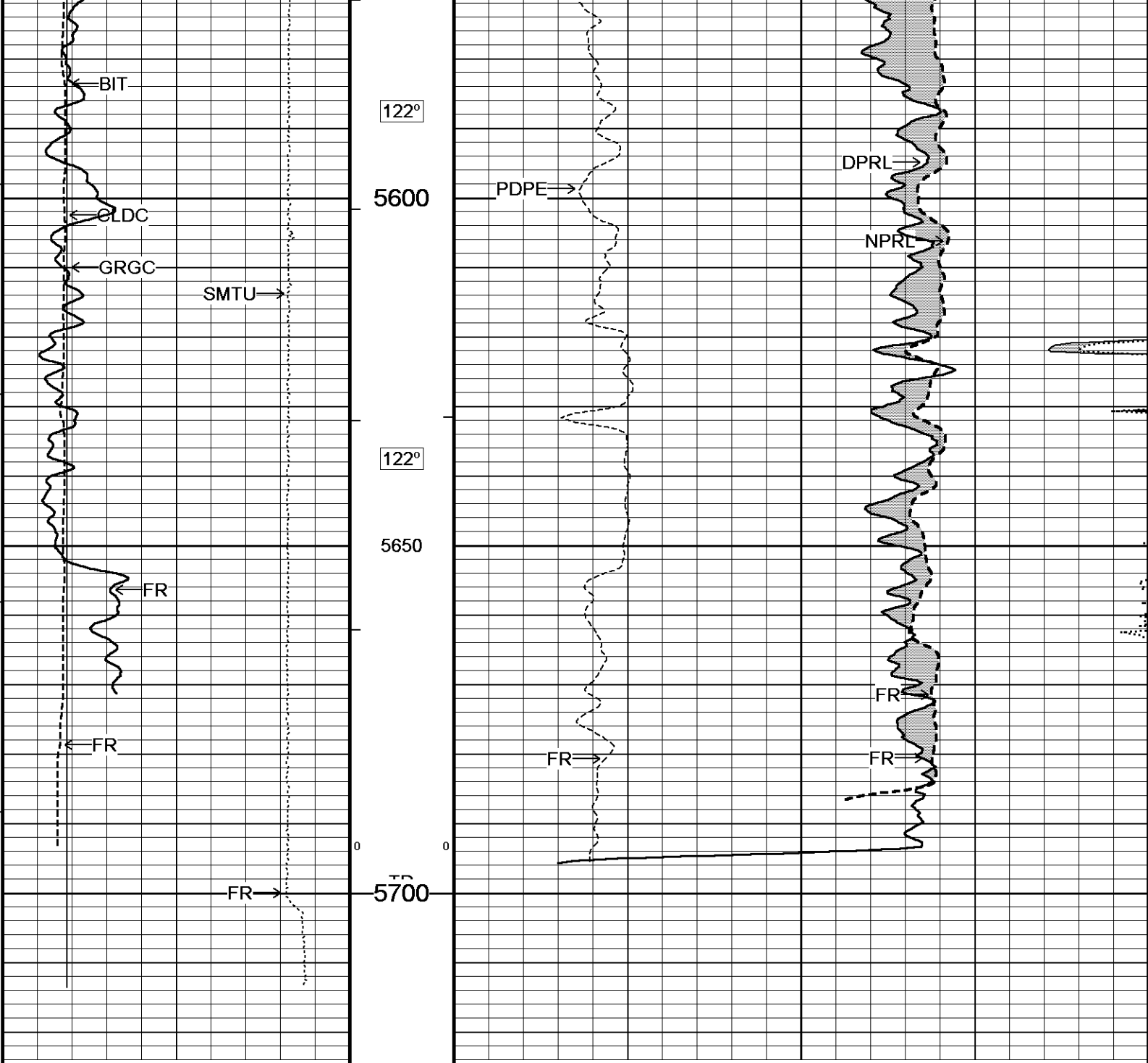

Depth in Feet

Borehole Temp in deg F

HVI every 10 cu ft

Annular Integral every

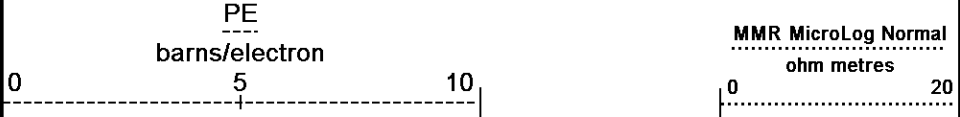
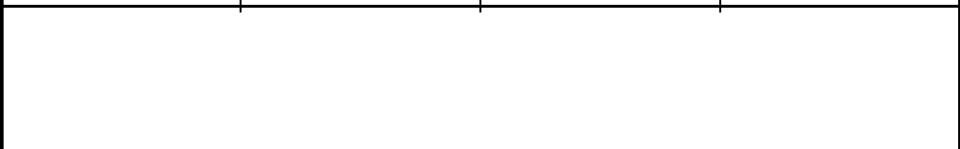
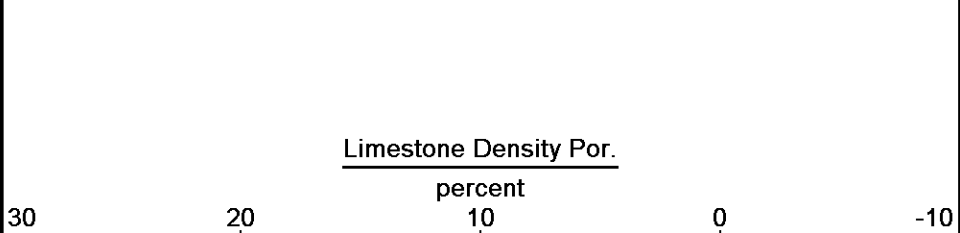
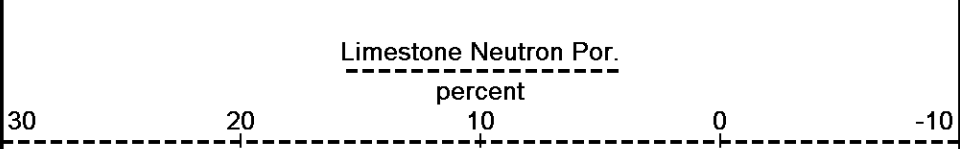

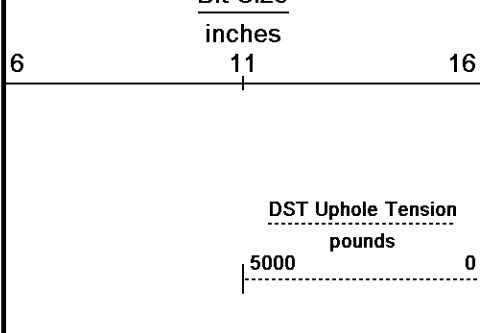

10 cu ft  
Replay  
Scale  
1:240



Depth Based Data - Maximum Sampling Increment 10.0cm  
 Plotted on 01-NOV-2014 04:56  
 Filename: C:\Minimus 14.03.4558\Logs\McCoy UMCC 'A' #2-17\McCoy UMCC 'A' #2-17\_004.dta  
 Recorded on 01-NOV-2014 02:34  
 System Versions: Logged with 14.03.4558 Processed with 14.03.4558 Plotted with 14.03.4558

5 INCH MAIN

10 INCH HIGH RESOLUTION  
 Depth Based Data - Maximum Sampling Increment 2.5cm  
 Plotted on 01-NOV-2014 04:56  
 Filename: C:\Minimus 14.03.4558\Logs\McCoy UMCC 'A' #2-17\McCoy UMCC 'A' #2-17\_002.dta  
 Recorded on 01-NOV-2014 01:41  
 System Versions: Logged with 14.03.4558 Plotted with 14.03.4558

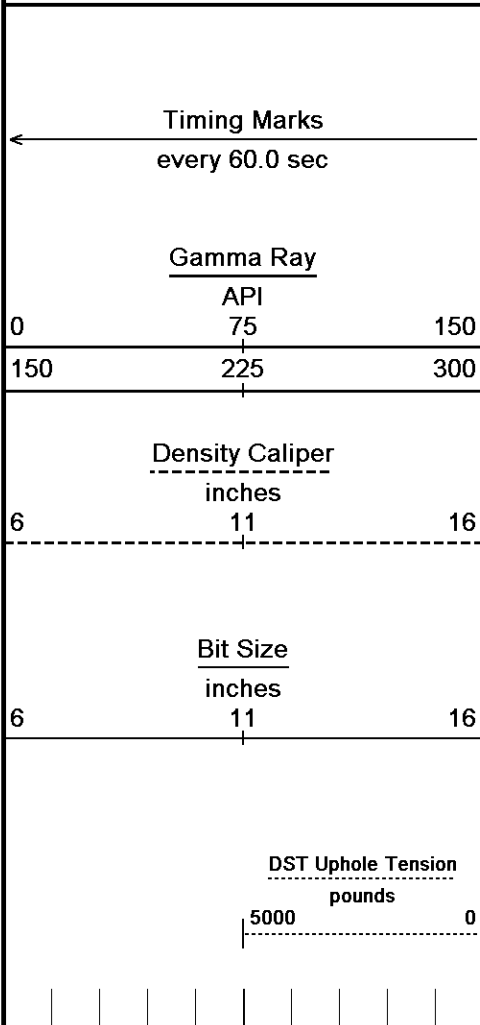

Depth  
in  
Feet  
Borehole  
Temp in  
deg F  
HVI  
every  
10 cu ft  
Annular  
Integral  
every  
10 cu ft  
Replay  
Scale  
1:120

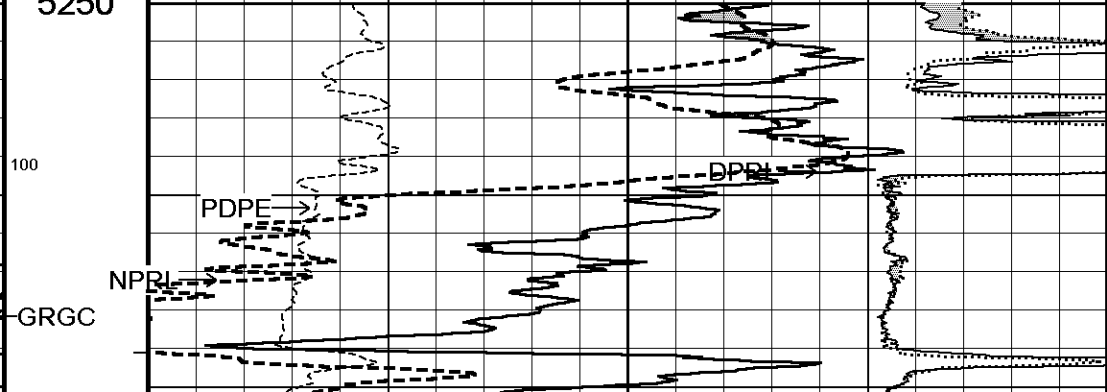
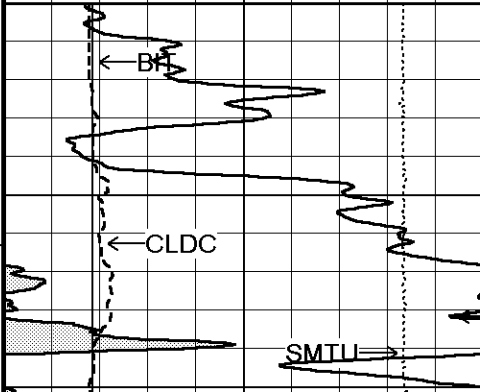
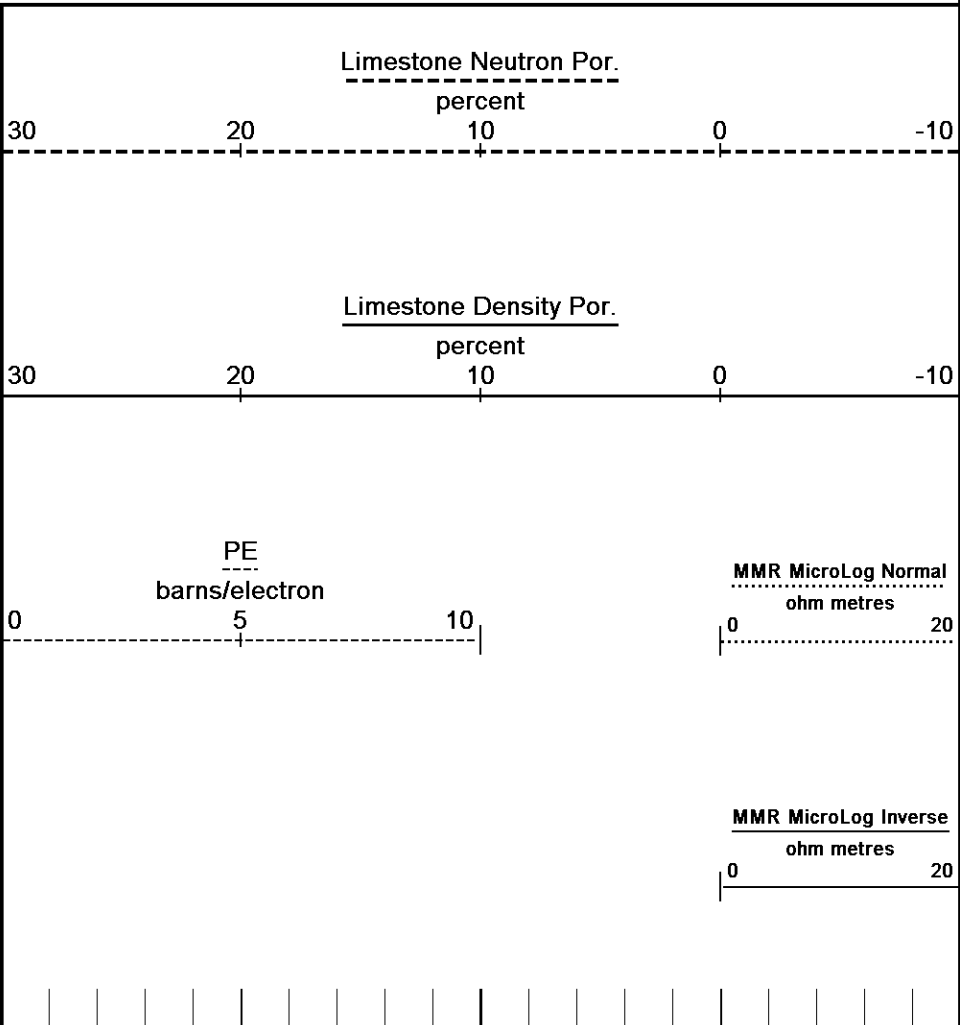

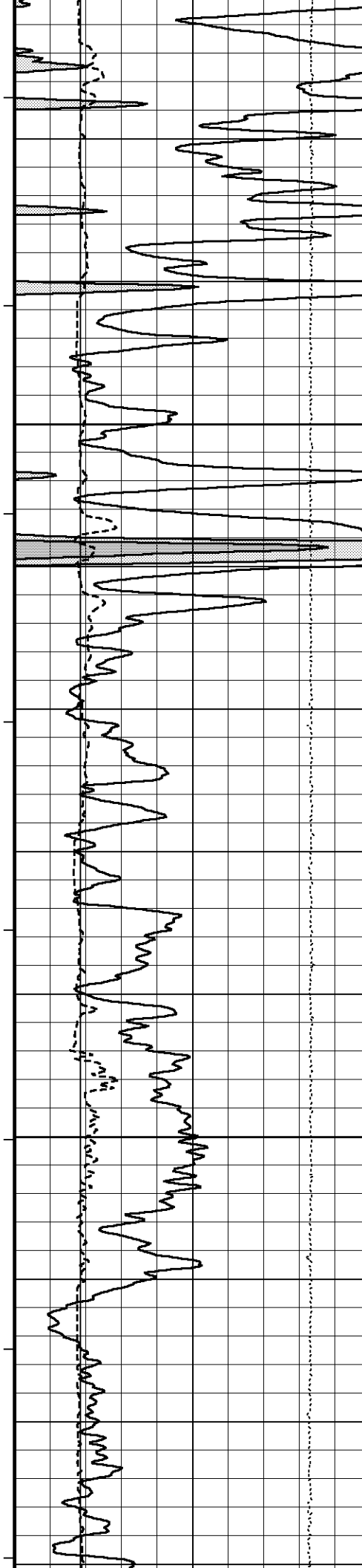

116°

5300

117°

5350

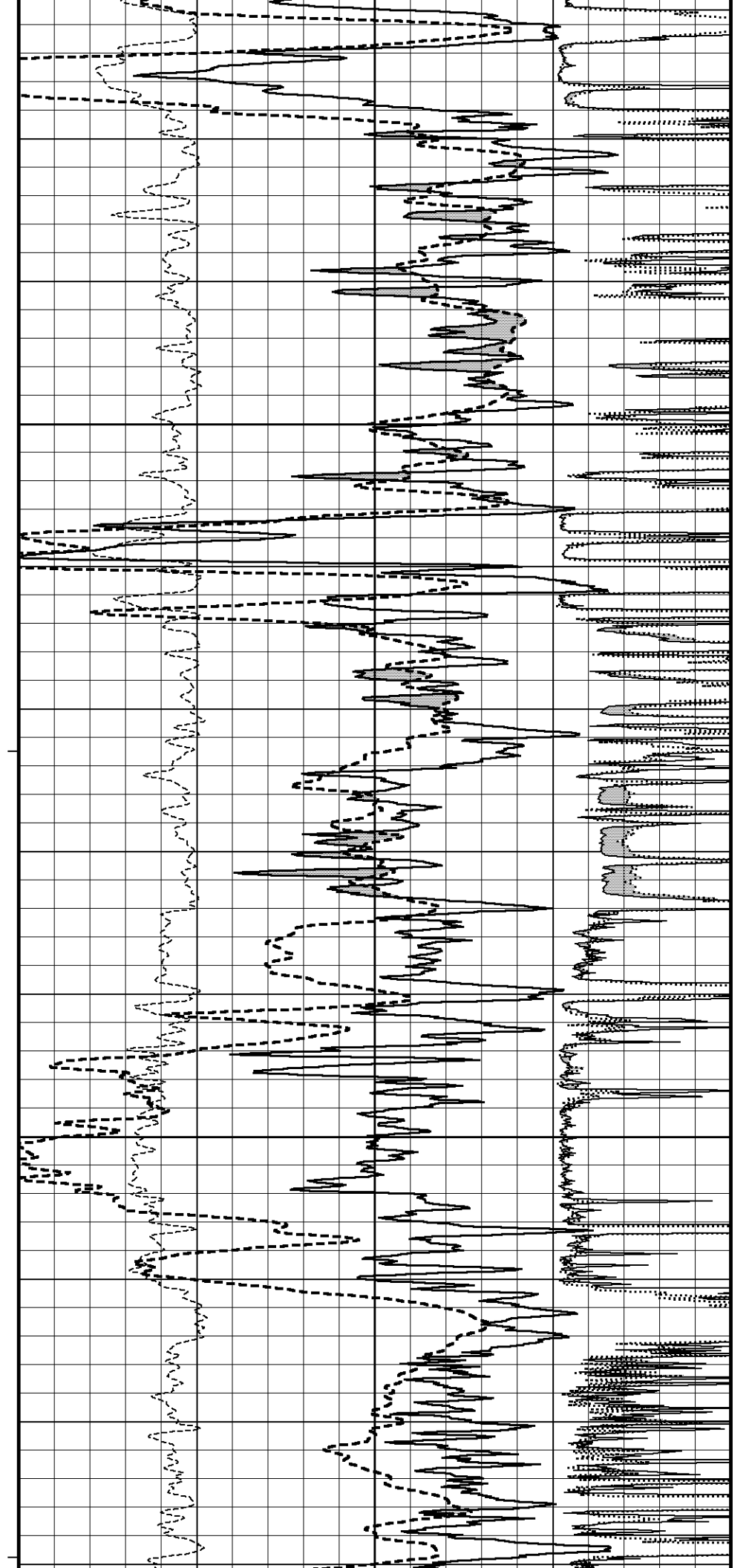

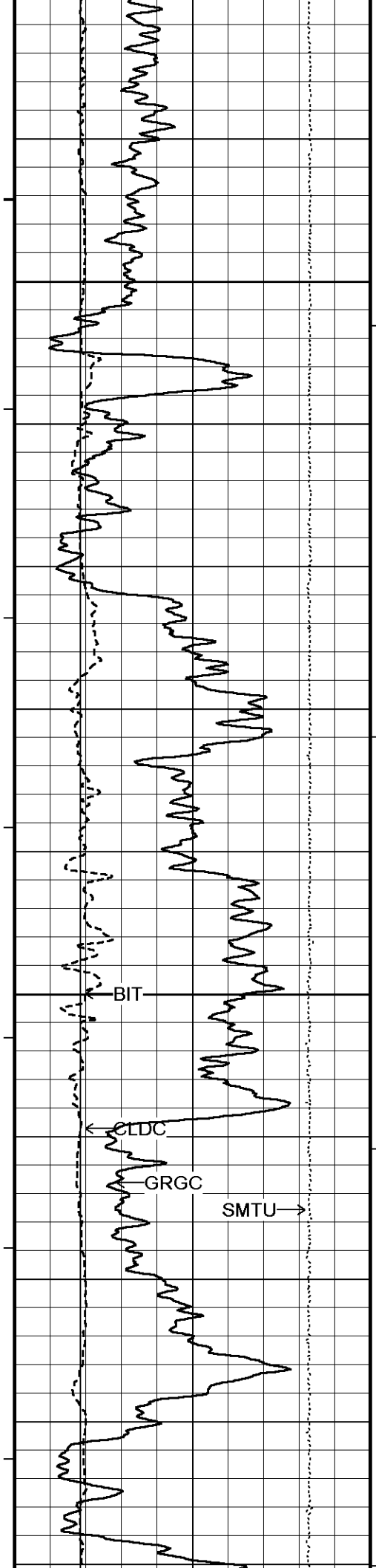

118°

5400

118°

5450

119°

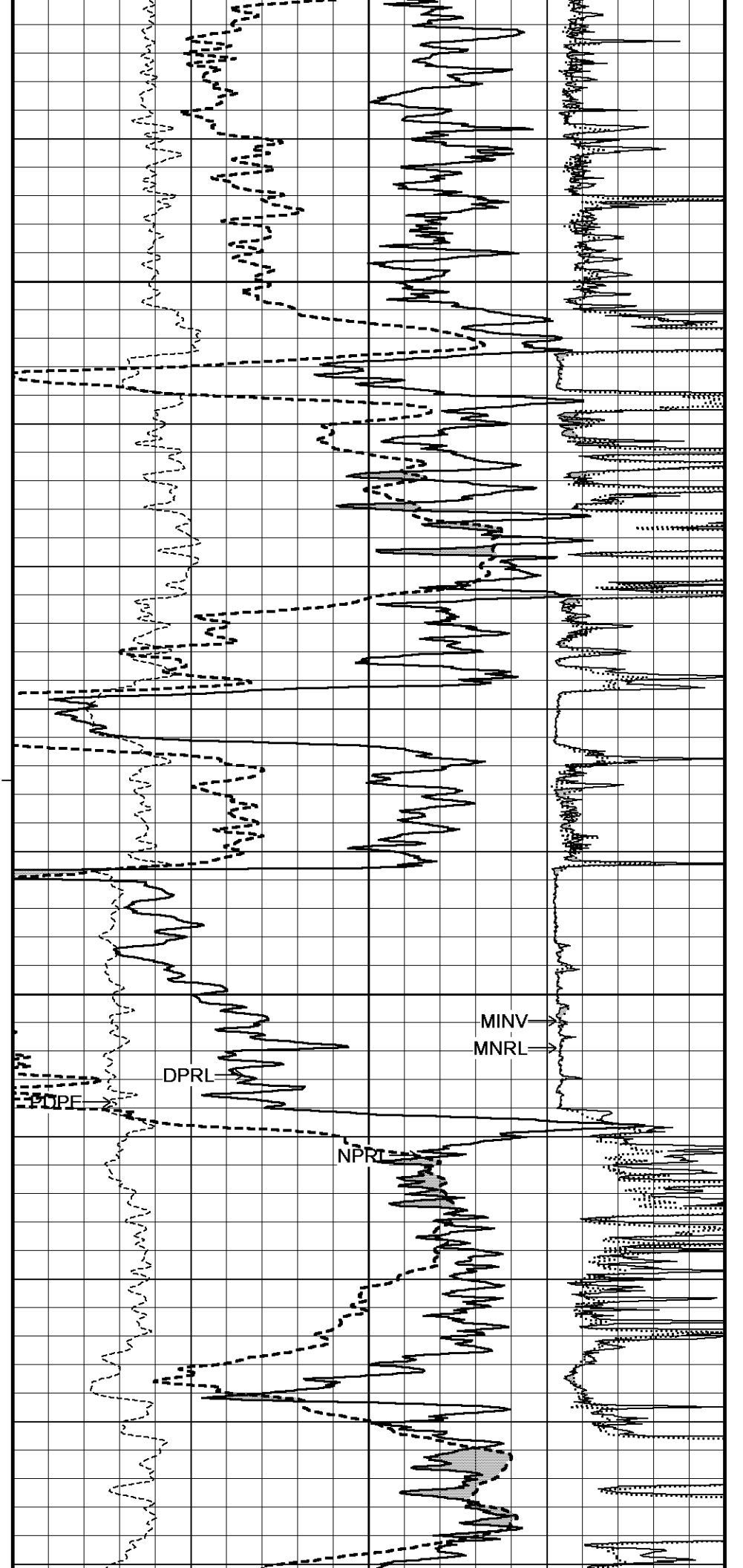

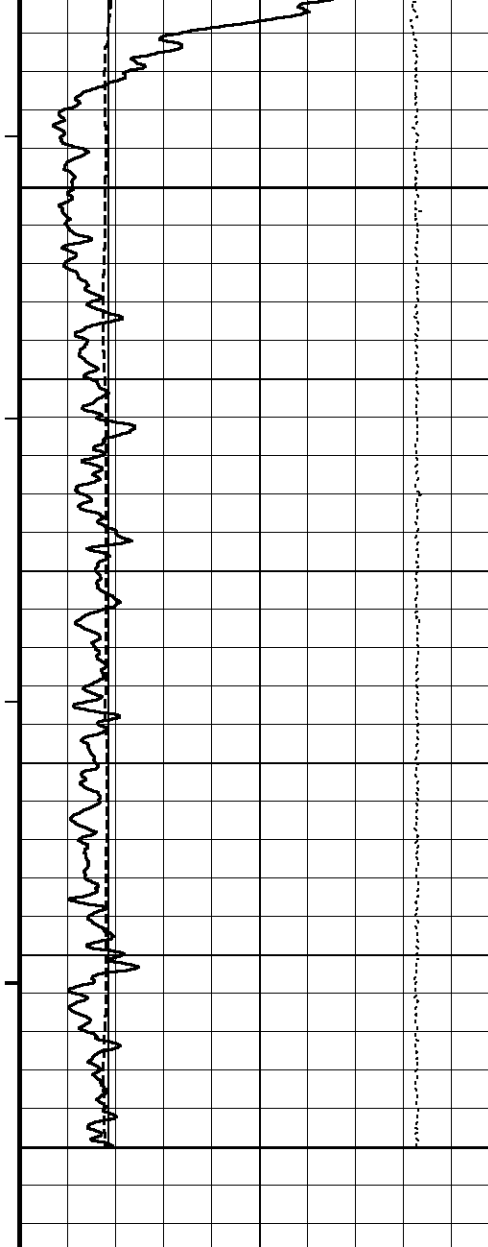

5500

119°

5550

Depth  
in  
Feet

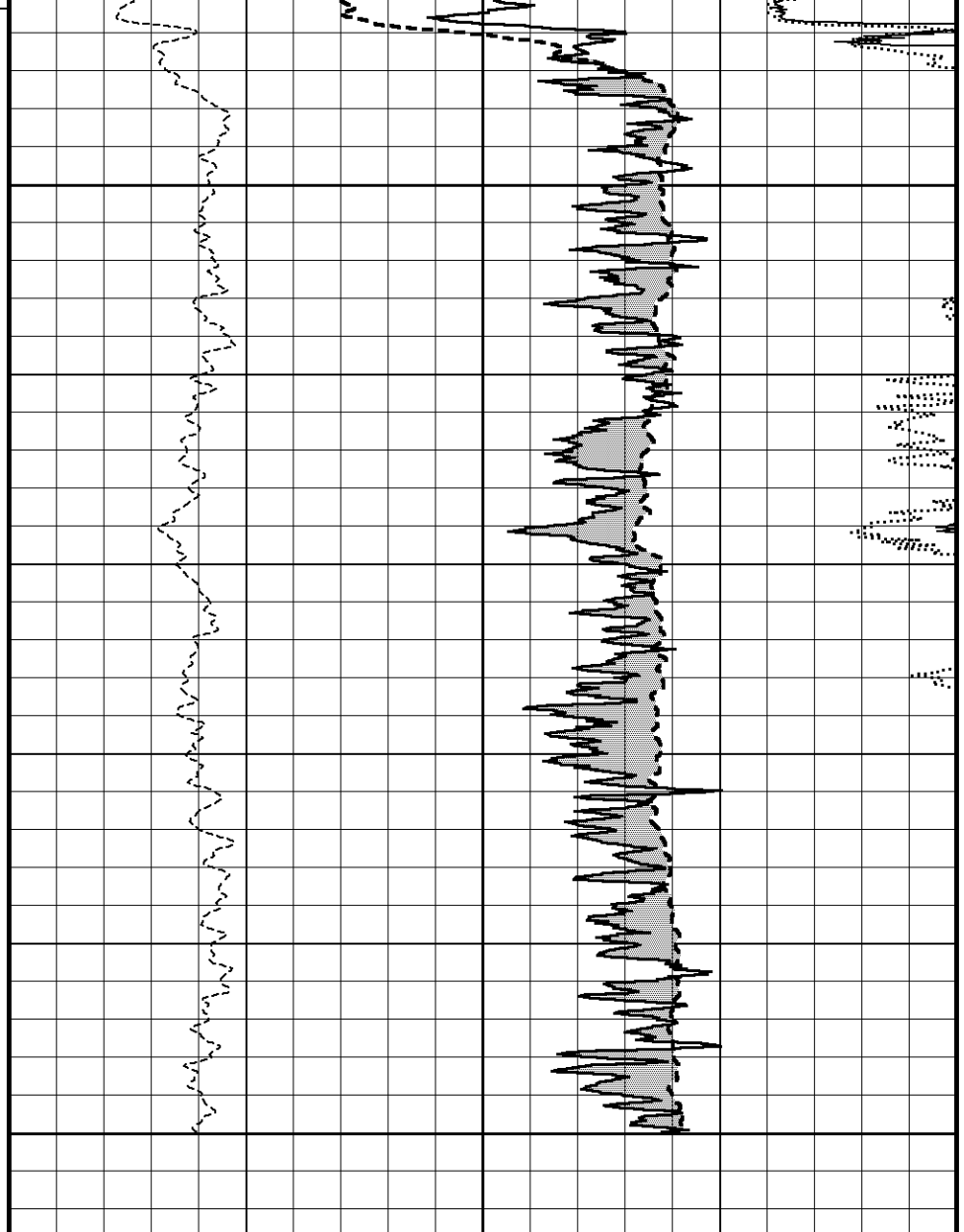

Timing Marks  
every 60.0 sec

Gamma Ray  
API

Density Caliper  
inches

Bit Size  
inches

DST Uphole Tension

Borehole  
Temp in  
deg F

HVI  
every  
10 cu ft

Annular  
Integral  
every  
10 cu ft

PE  
barns/electron

MMR MicroLog Normal  
ohm metres

MMR MicroLog Inverse  
ohm metres

0 75 150

150 225 300

6 11 16

6 11 16

30 20 10 0 -10

30 20 10 0 -10

0 5 10

0 20

0 20

5000 pounds 0

Replay Scale 1:120

Depth Based Data - Maximum Sampling Increment 2.5cm  
 Plotted on 01-NOV-2014 04:56  
 Filename: C:\Minimus 14.03.4558\Logs\McCoy UMCC 'A' #2-17\McCoy UMCC 'A' #2-17\_002.dta  
 Recorded on 01-NOV-2014 01:41  
 System Versions: Logged with 14.03.4558 Plotted with 14.03.4558

↑ 10 INCH HIGH RESOLUTION ↑

↓ REPEAT SECTION ↓

Depth Based Data - Maximum Sampling Increment 10.0cm  
 Plotted on 01-NOV-2014 04:56  
 Filename: C:\Minimus 14.03.4558\Logs\McCoy UMCC 'A' #2-17\McCoy UMCC 'A' #2-17\_003.dta  
 Recorded on 01-NOV-2014 01:41  
 System Versions: Logged with 14.03.4558 Processed with 14.03.4558 Plotted with 14.03.4558

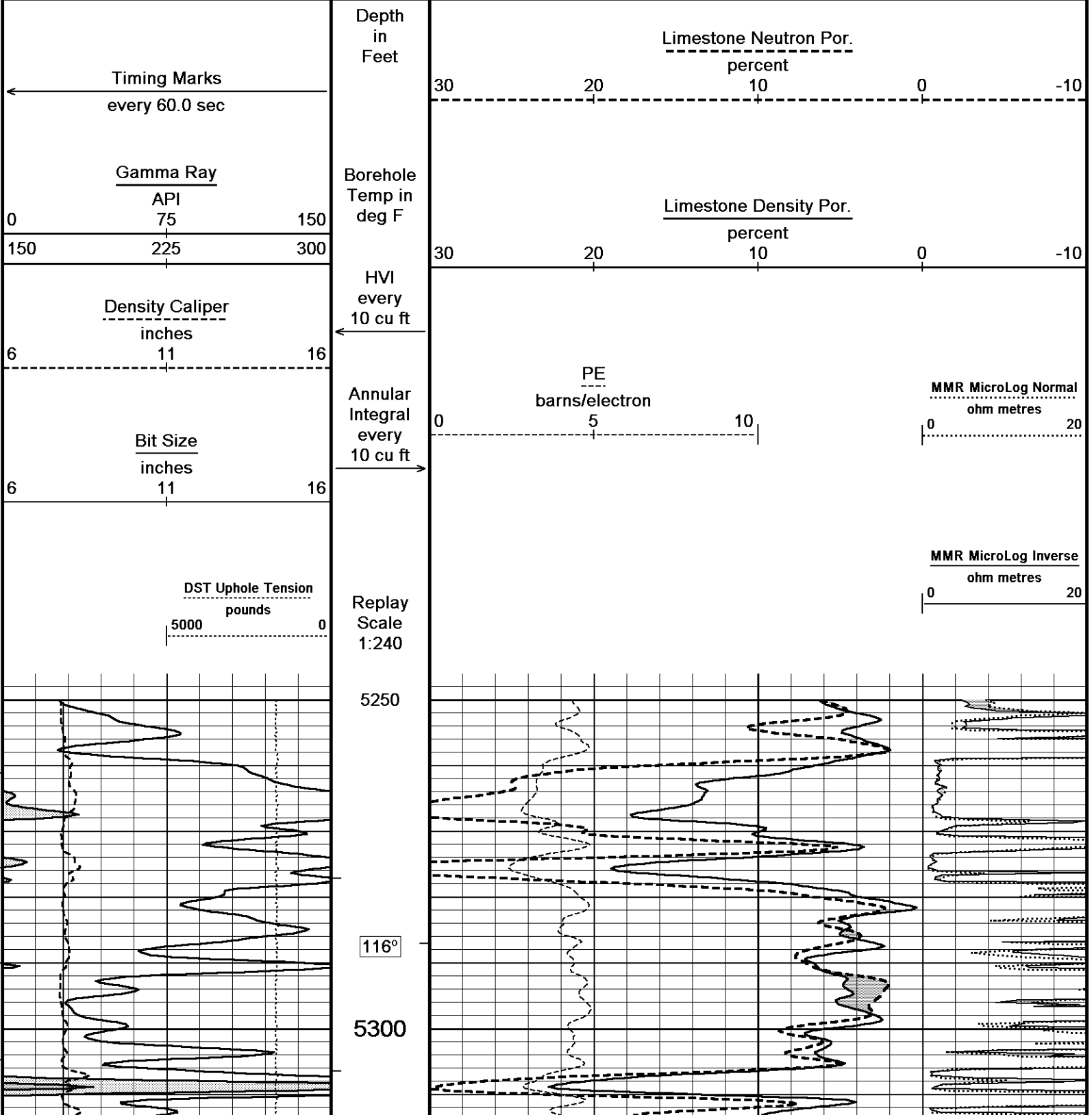

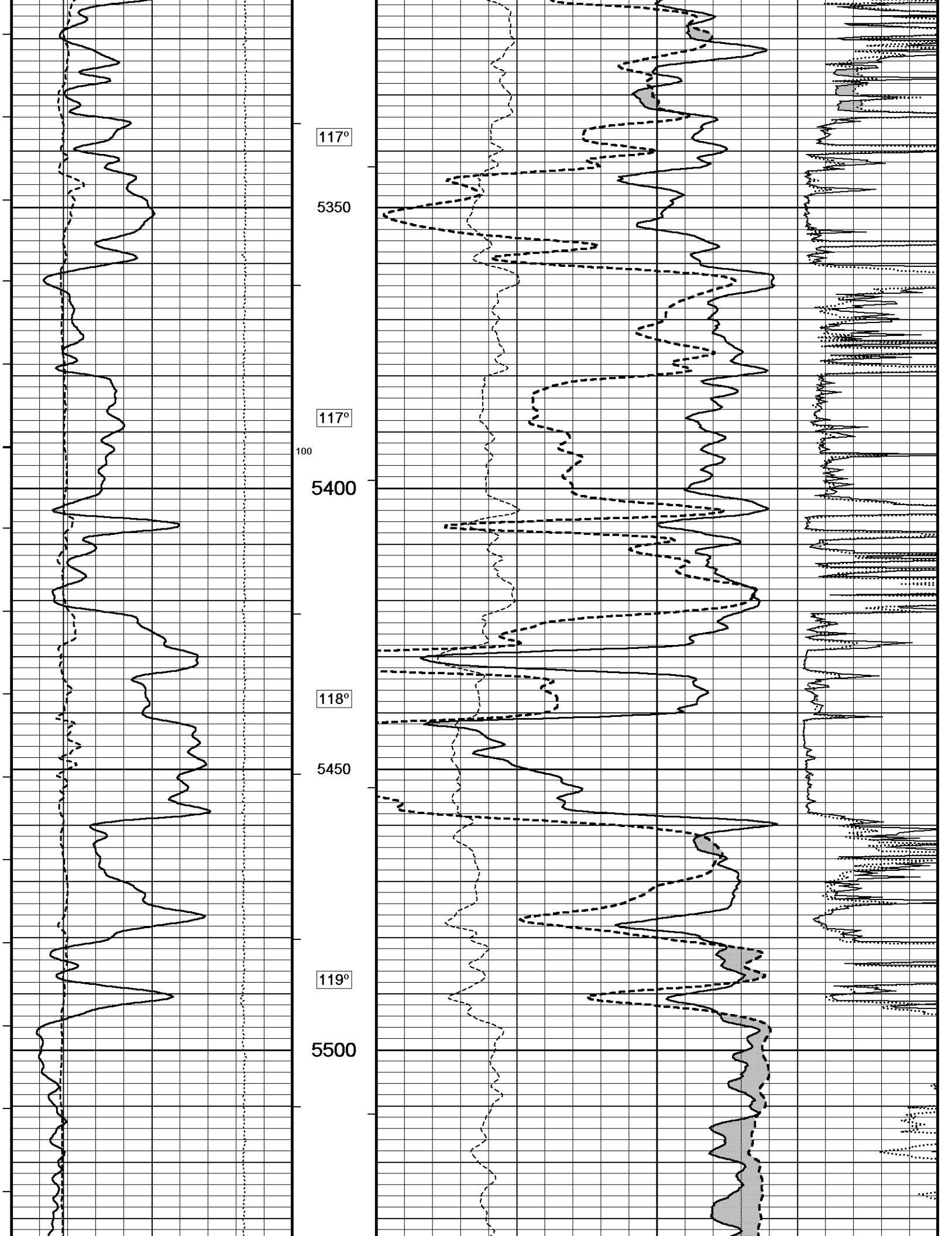

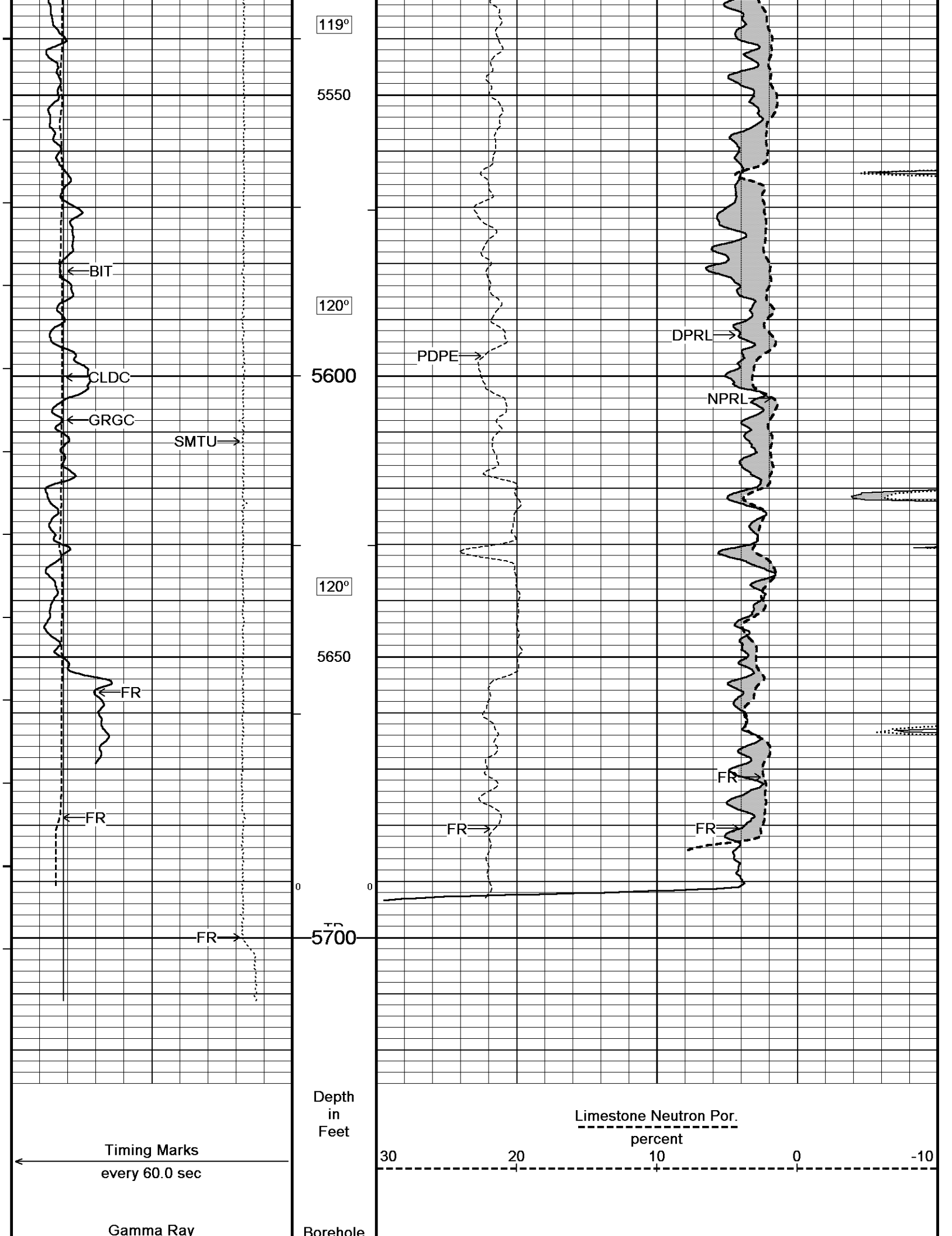

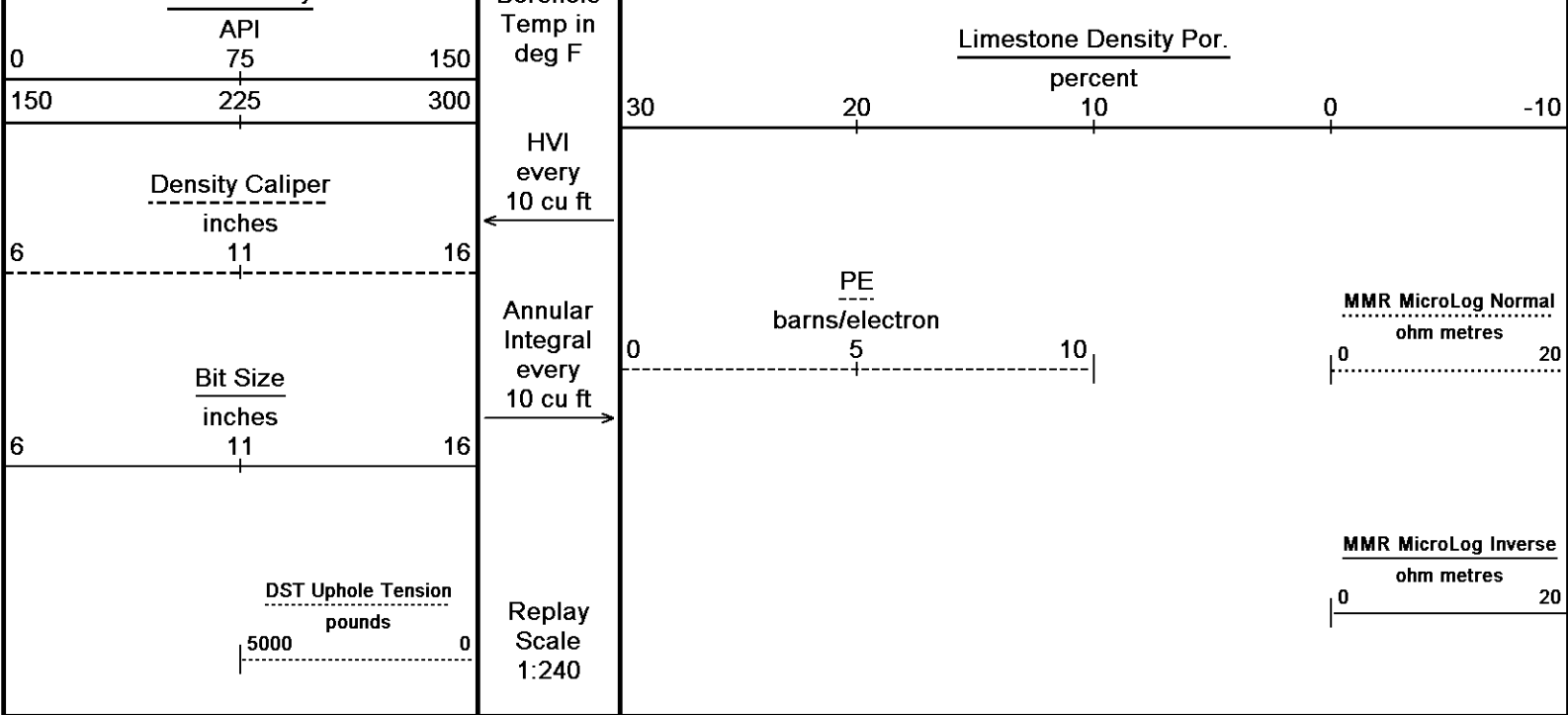

Depth Based Data - Maximum Sampling Increment 10.0cm Plotted on 01-NOV-2014 04:56  
 Filename: C:\Minimus 14.03.4558\Logs\McCoy UMCC 'A' #2-17\McCoy UMCC 'A' #2-17\_003.dta Recorded on 01-NOV-2014 01:41  
 System Versions: Logged with 14.03.4558 Processed with 14.03.4558 Plotted with 14.03.4558

↑ REPEAT SECTION ↑

↓ 5 INCH MAIN ↓

Depth Based Data - Maximum Sampling Increment 10.0cm Plotted on 01-NOV-2014 04:56  
 Filename: C:\Minimus 14.03.4558\Logs\McCoy UMCC 'A' #2-17\McCoy UMCC 'A' #2-17\_004.dta Recorded on 01-NOV-2014 02:34  
 System Versions: Logged with 14.03.4558 Processed with 14.03.4558 Plotted with 14.03.4558

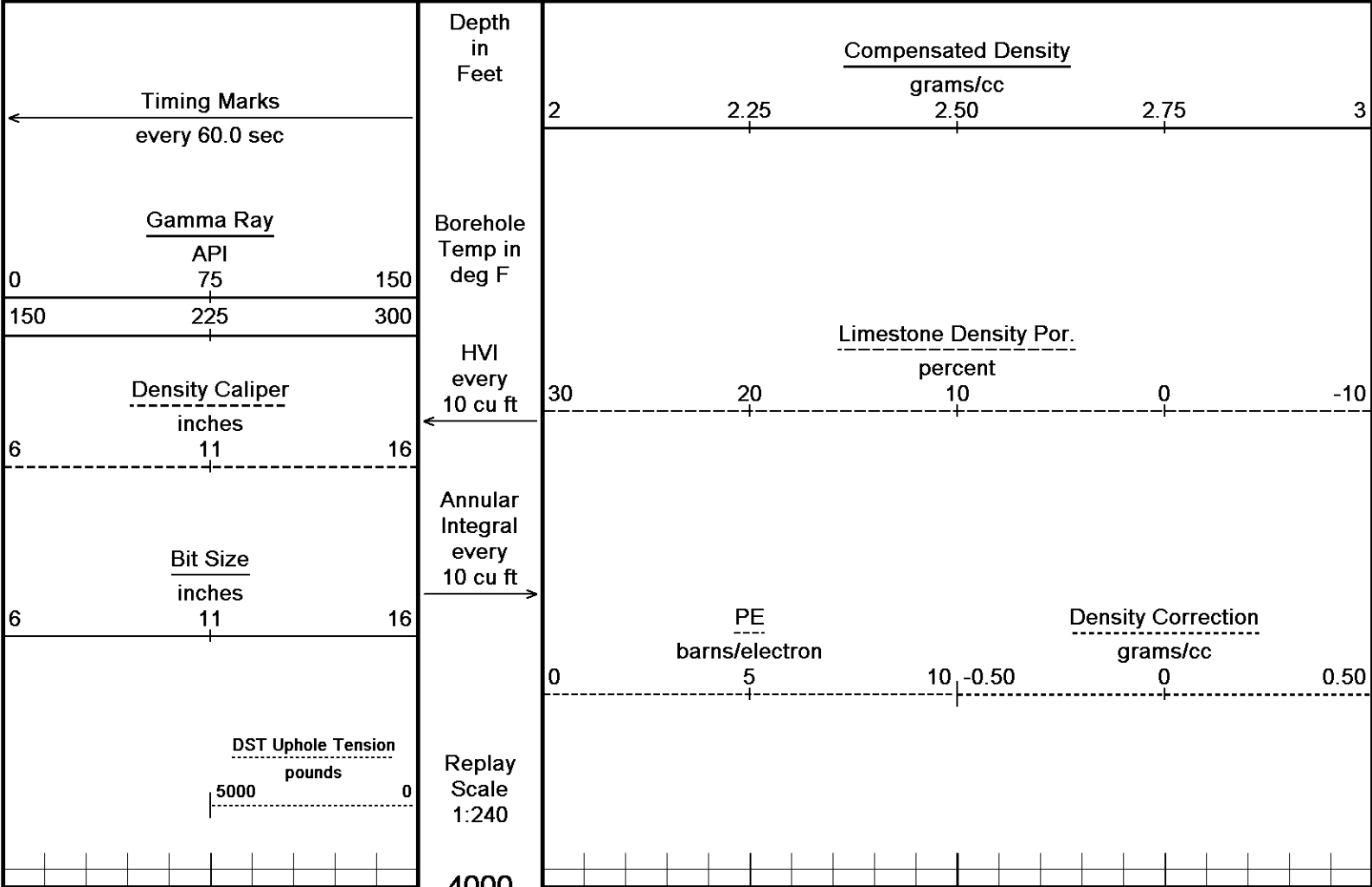

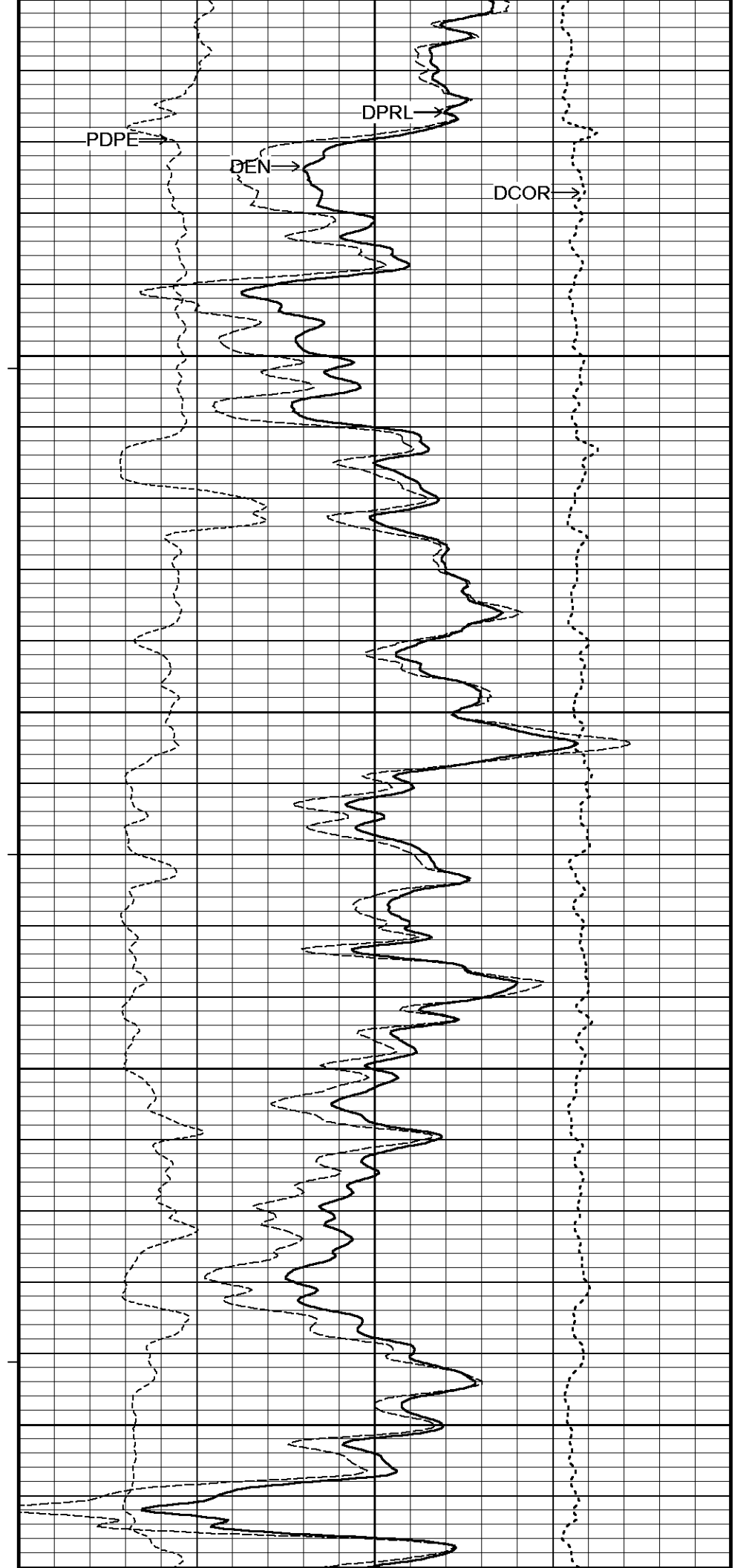
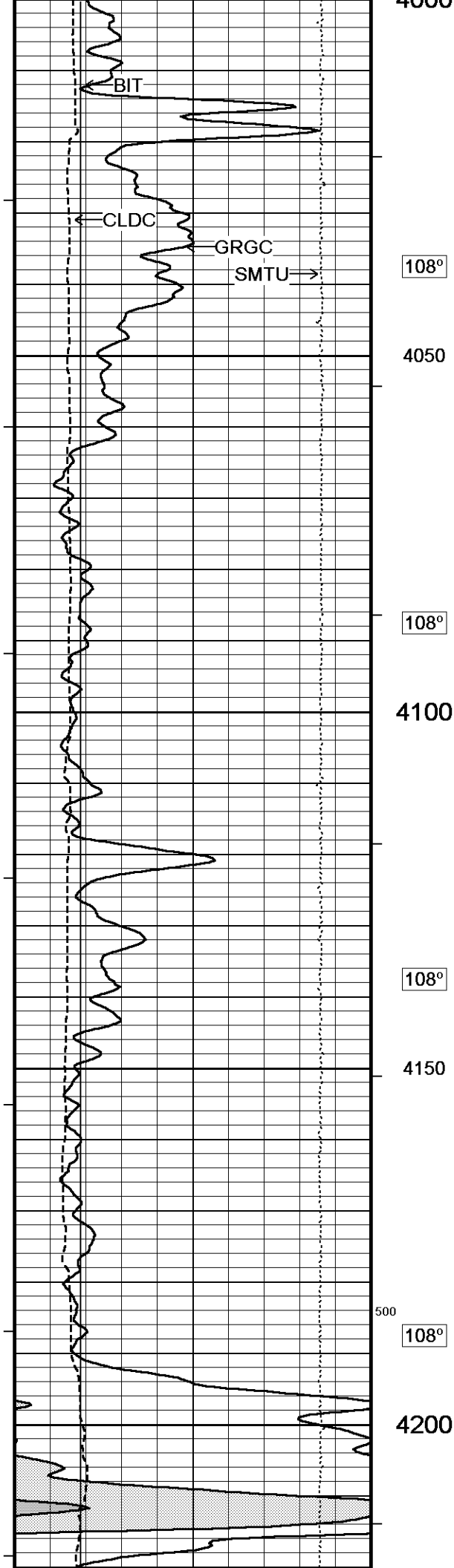

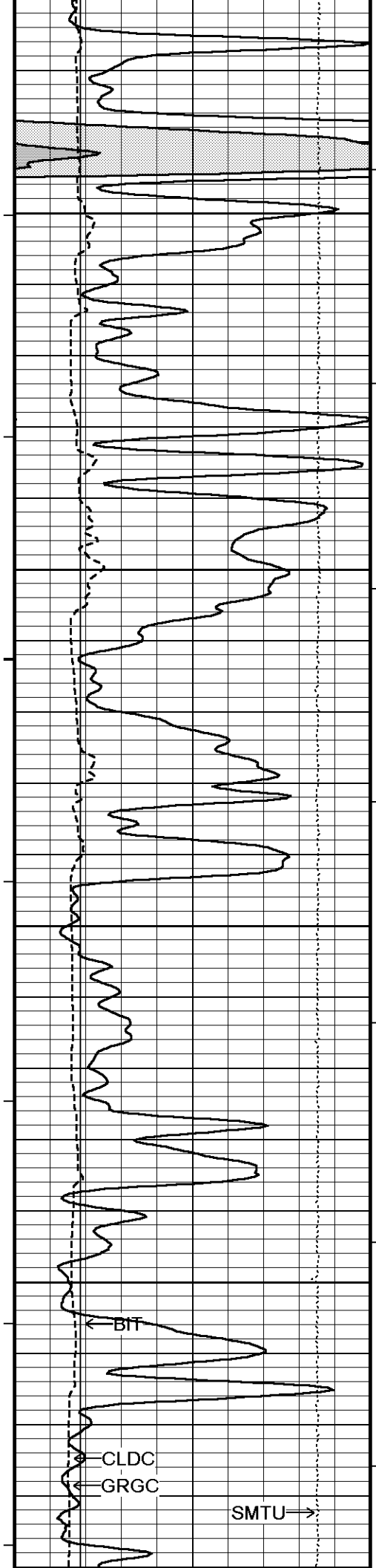

109°

4250

109°

4300

110°

4350

110°

4400

111°

← BIT

CLDC

GRGC

SMTU →

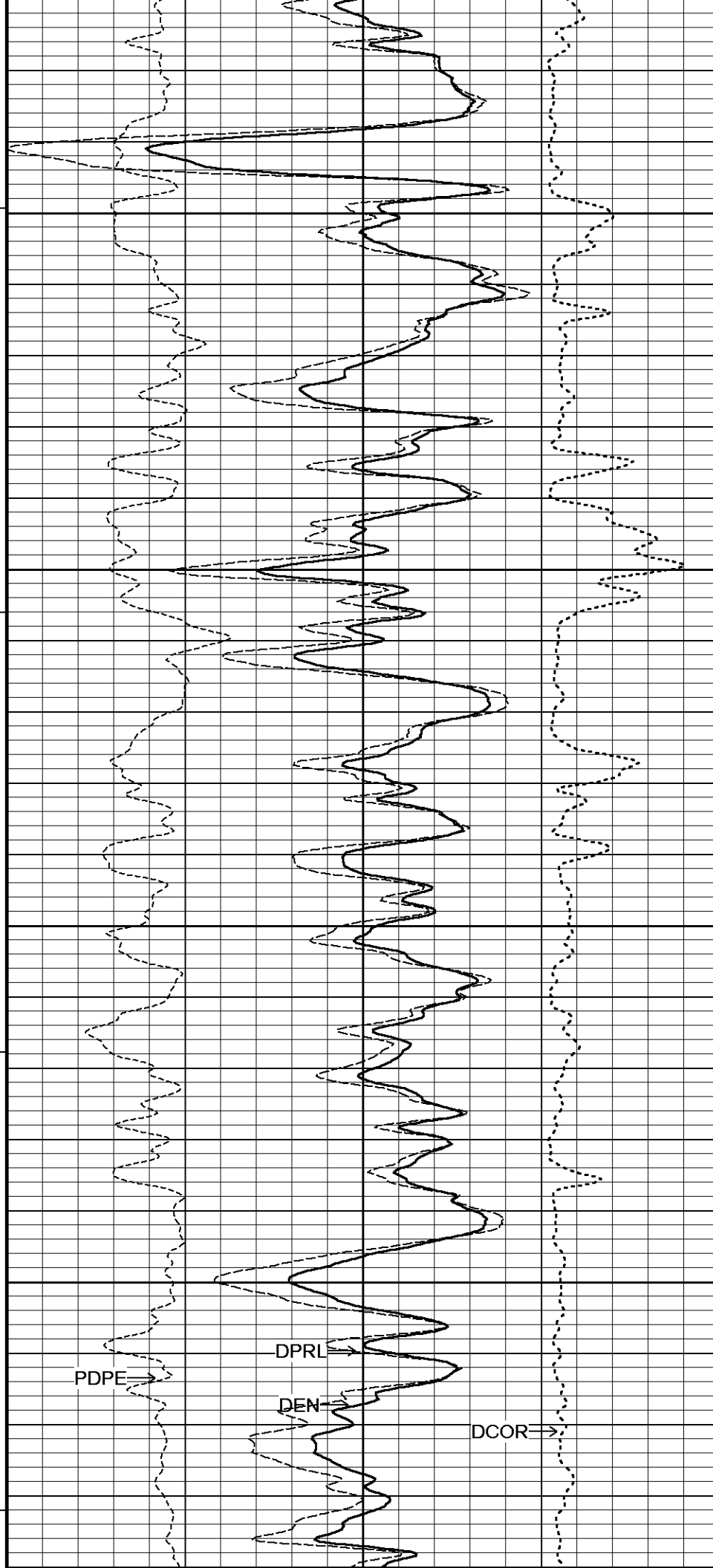

PDPE →

DPRL →

DEN →

DCOR →

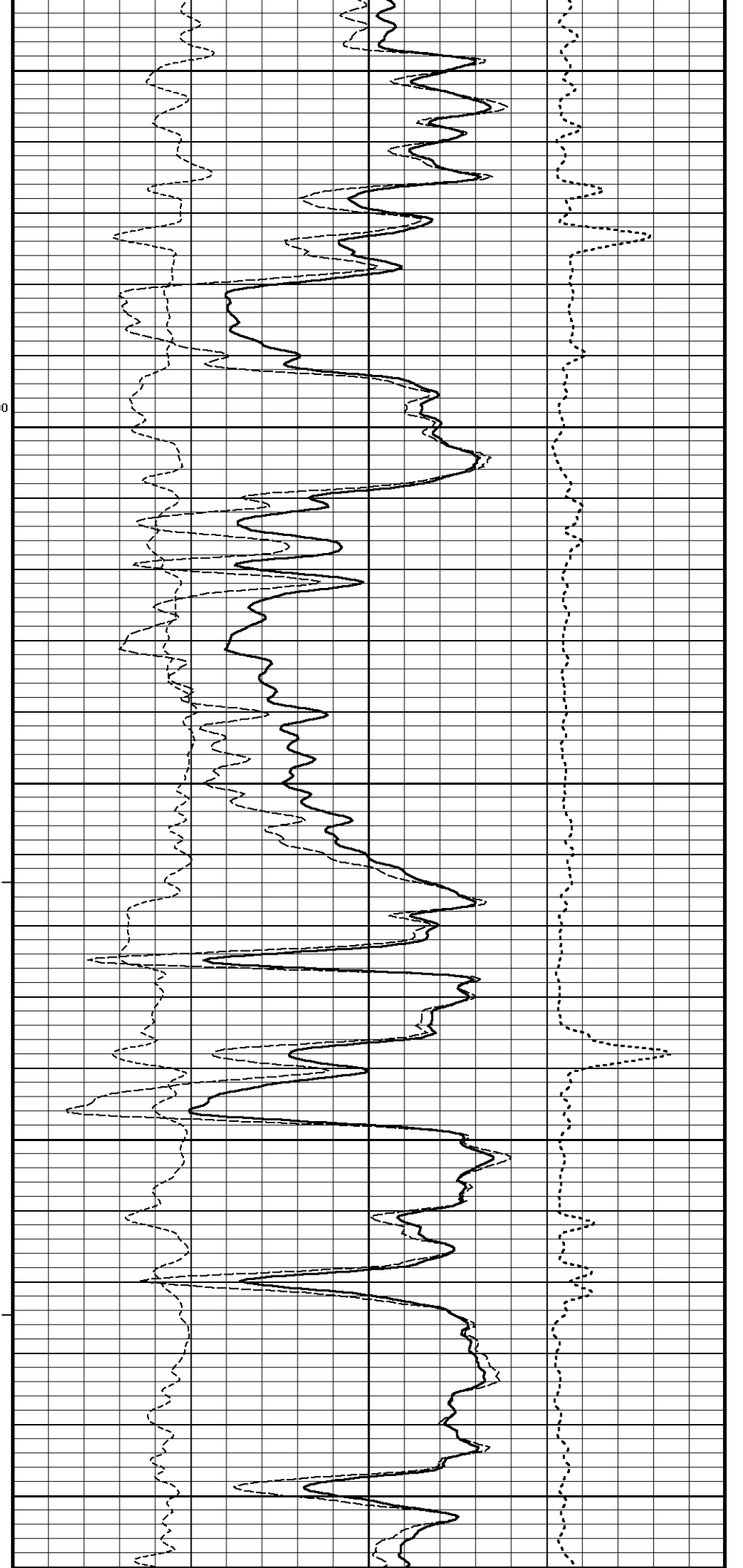
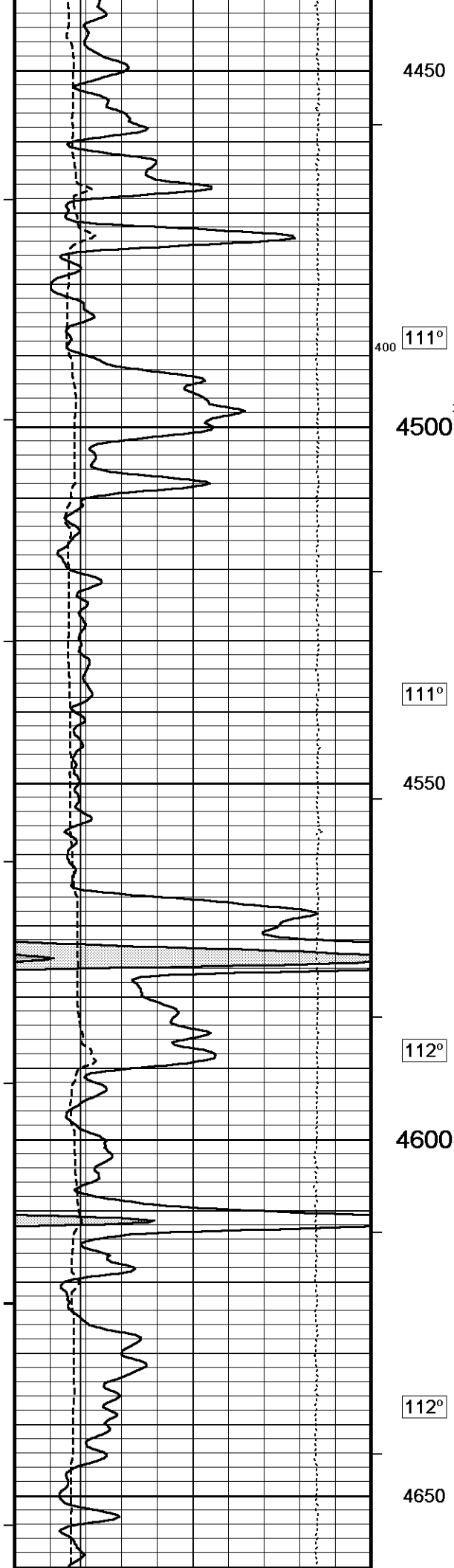

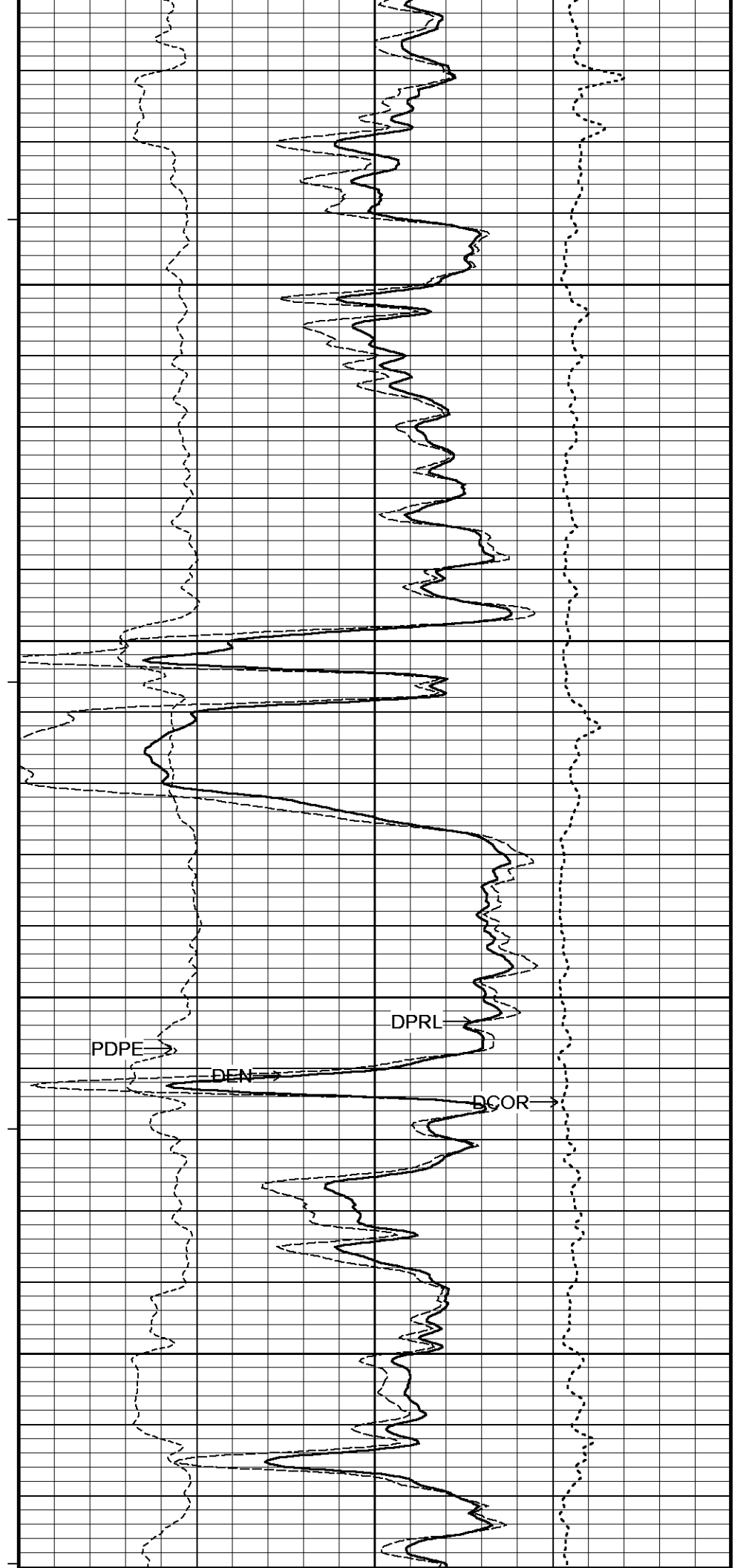
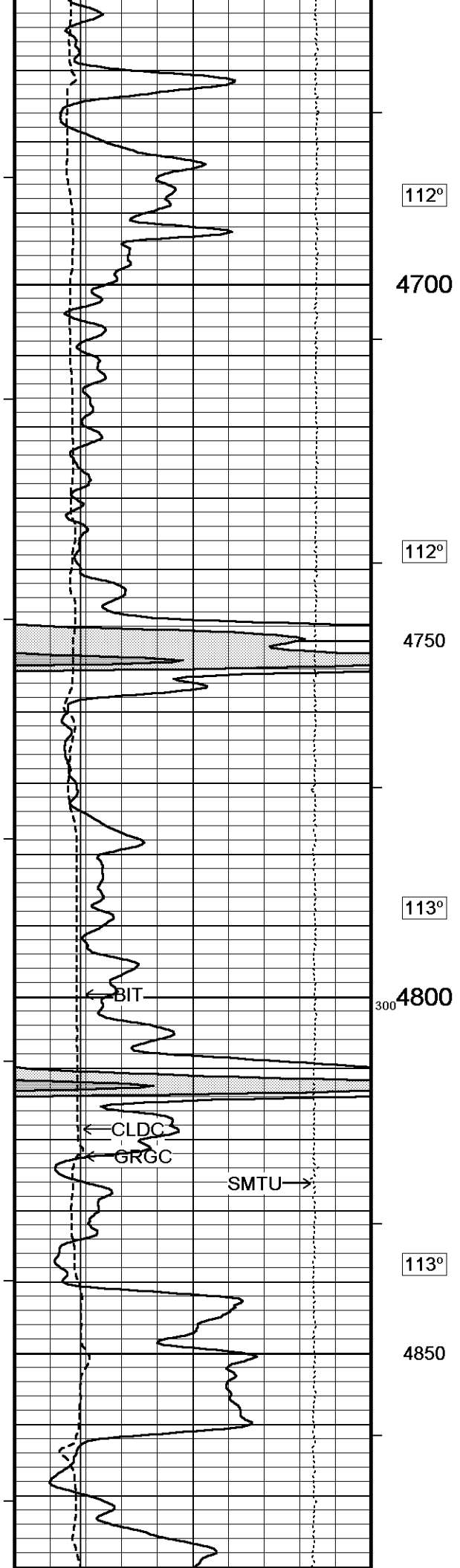

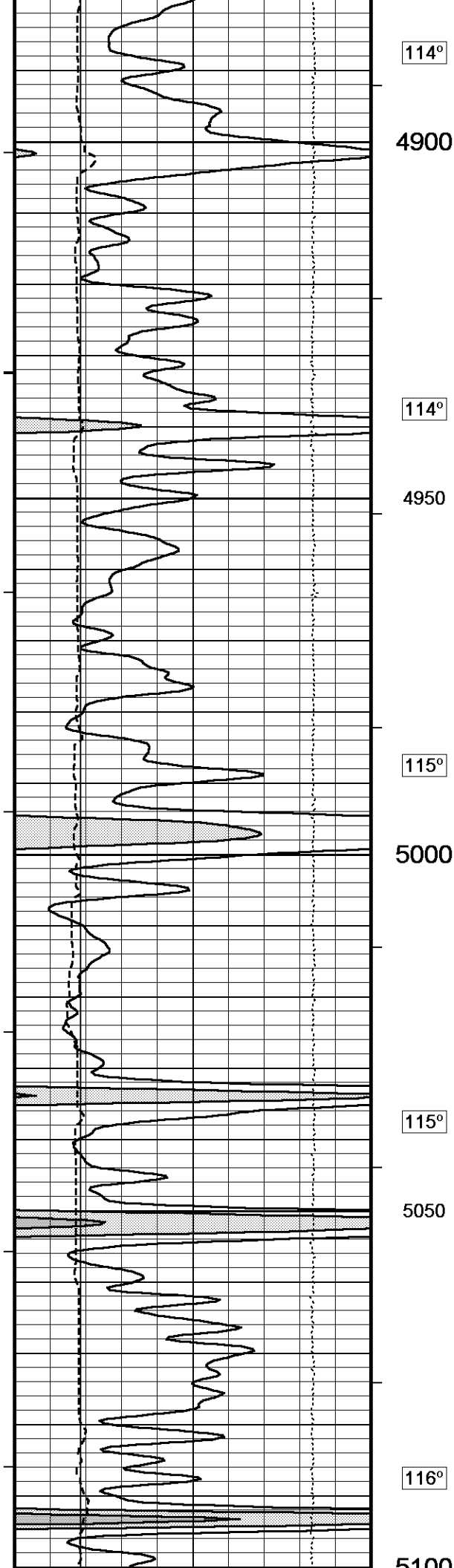

114°

4900

114°

4950

115°

5000

115°

5050

116°

5100

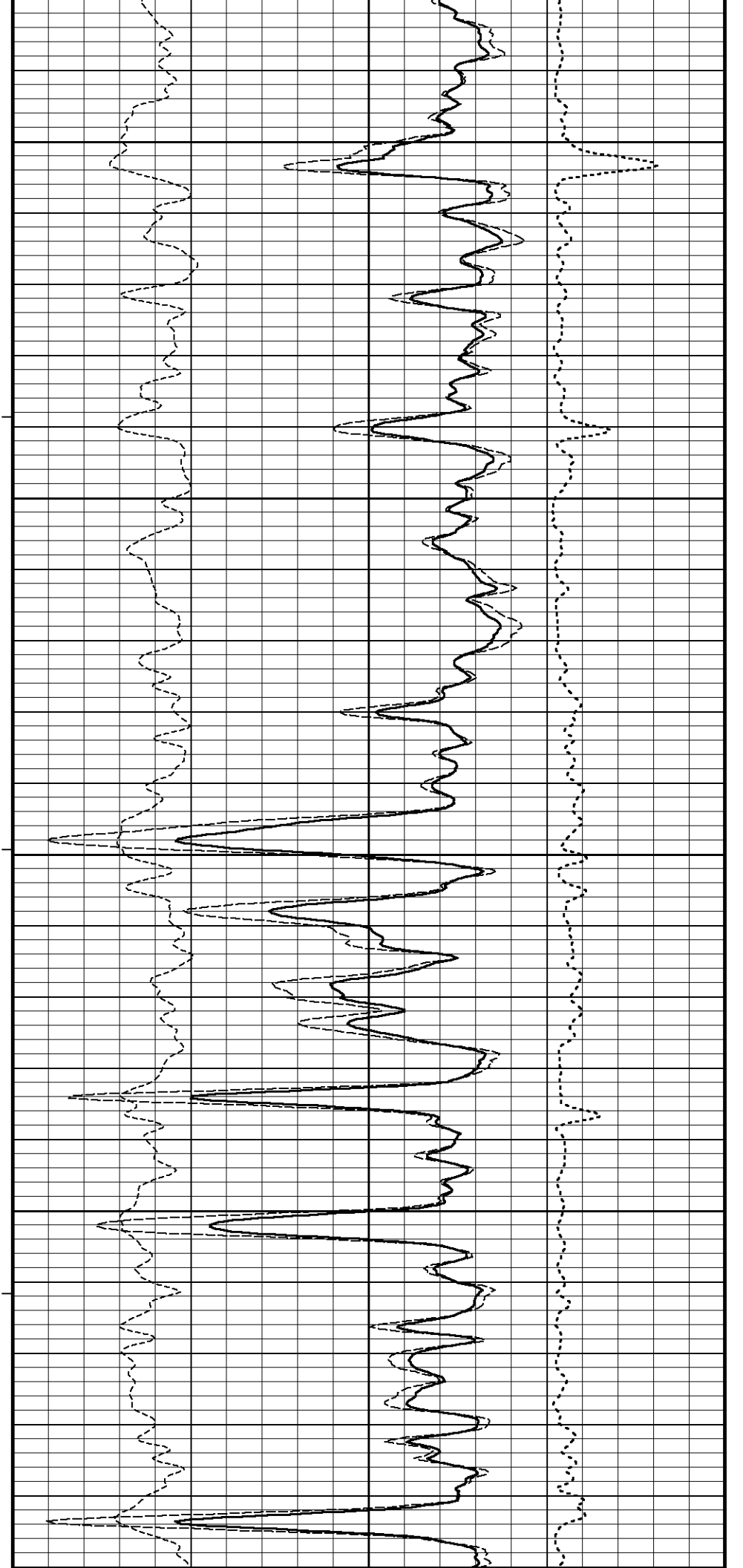

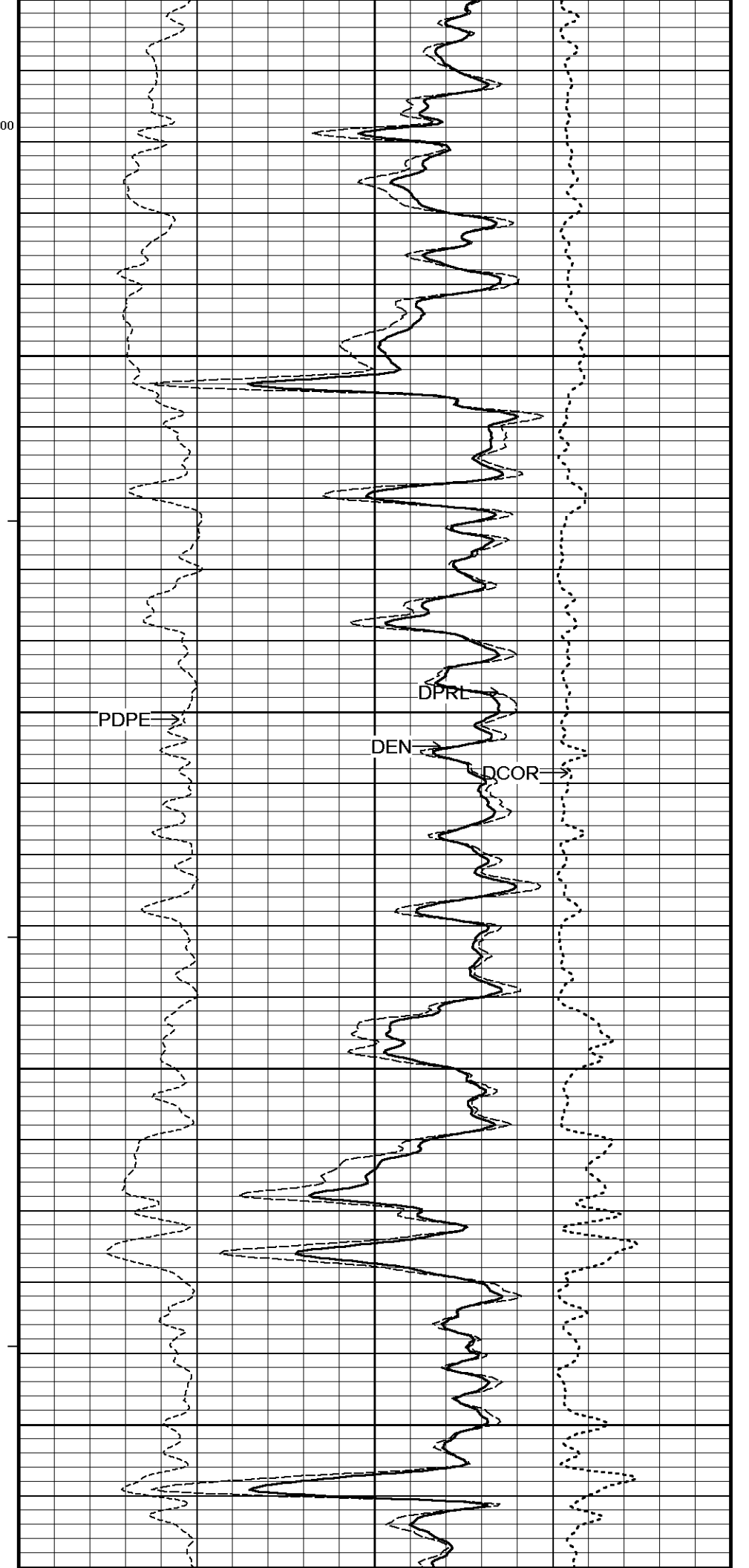
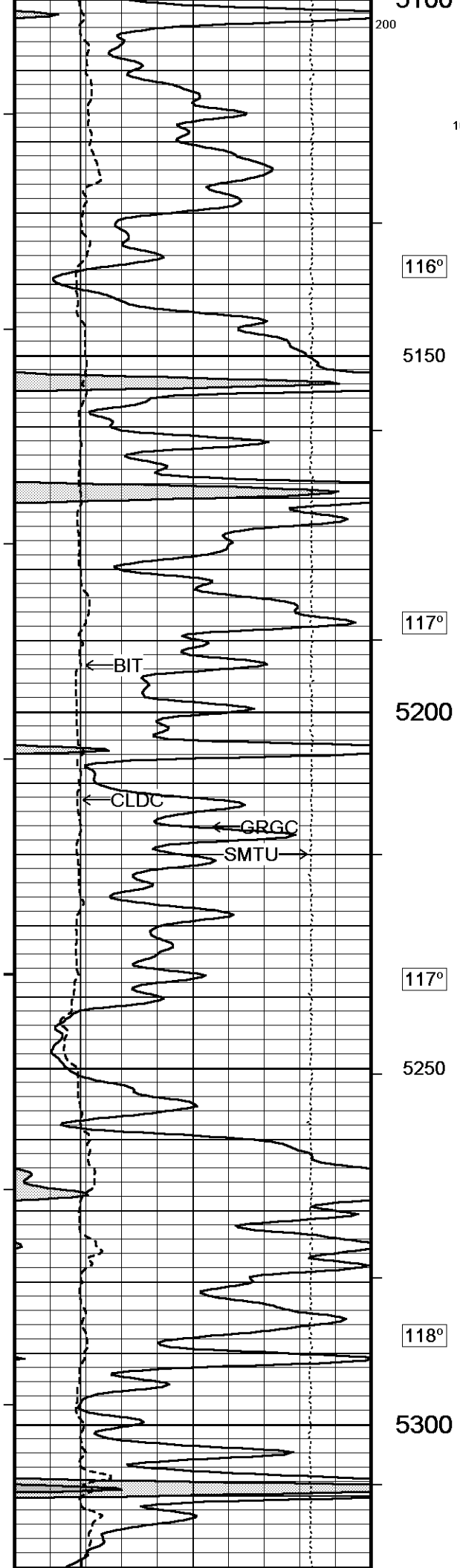

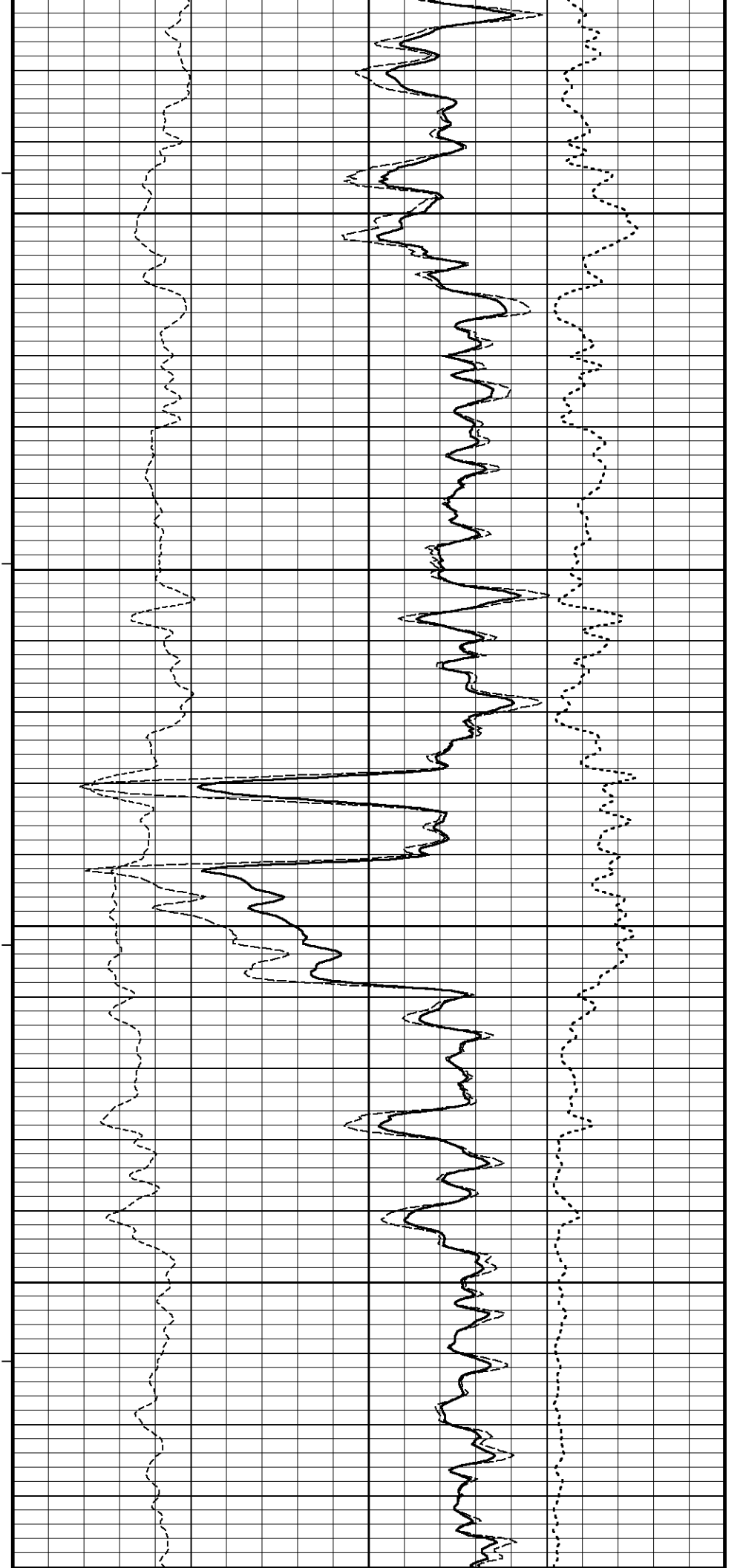
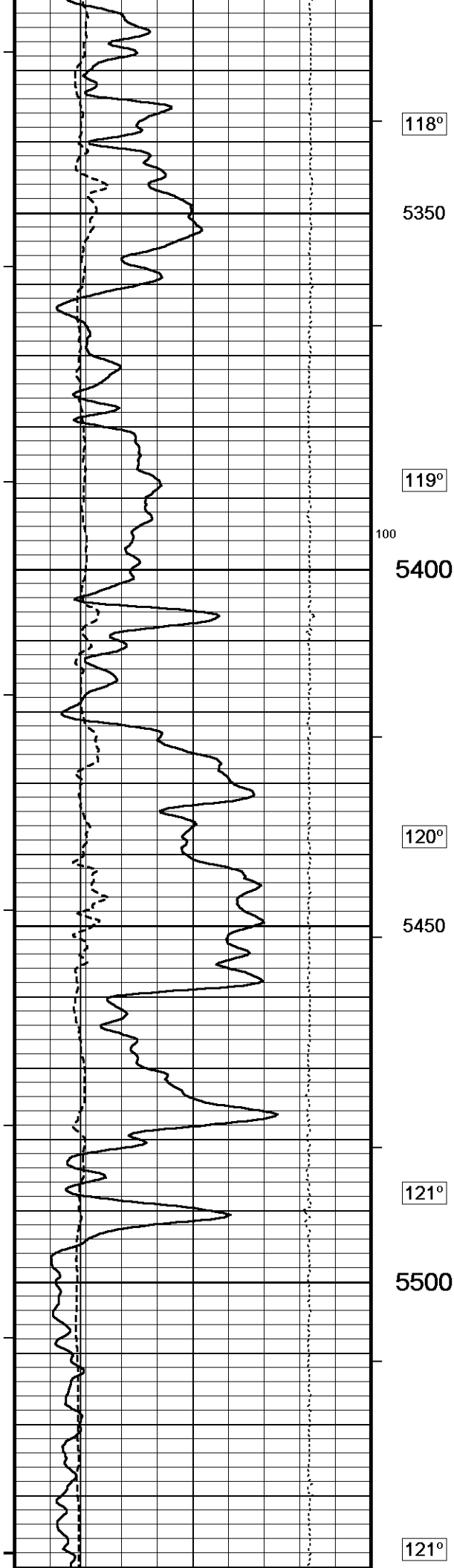

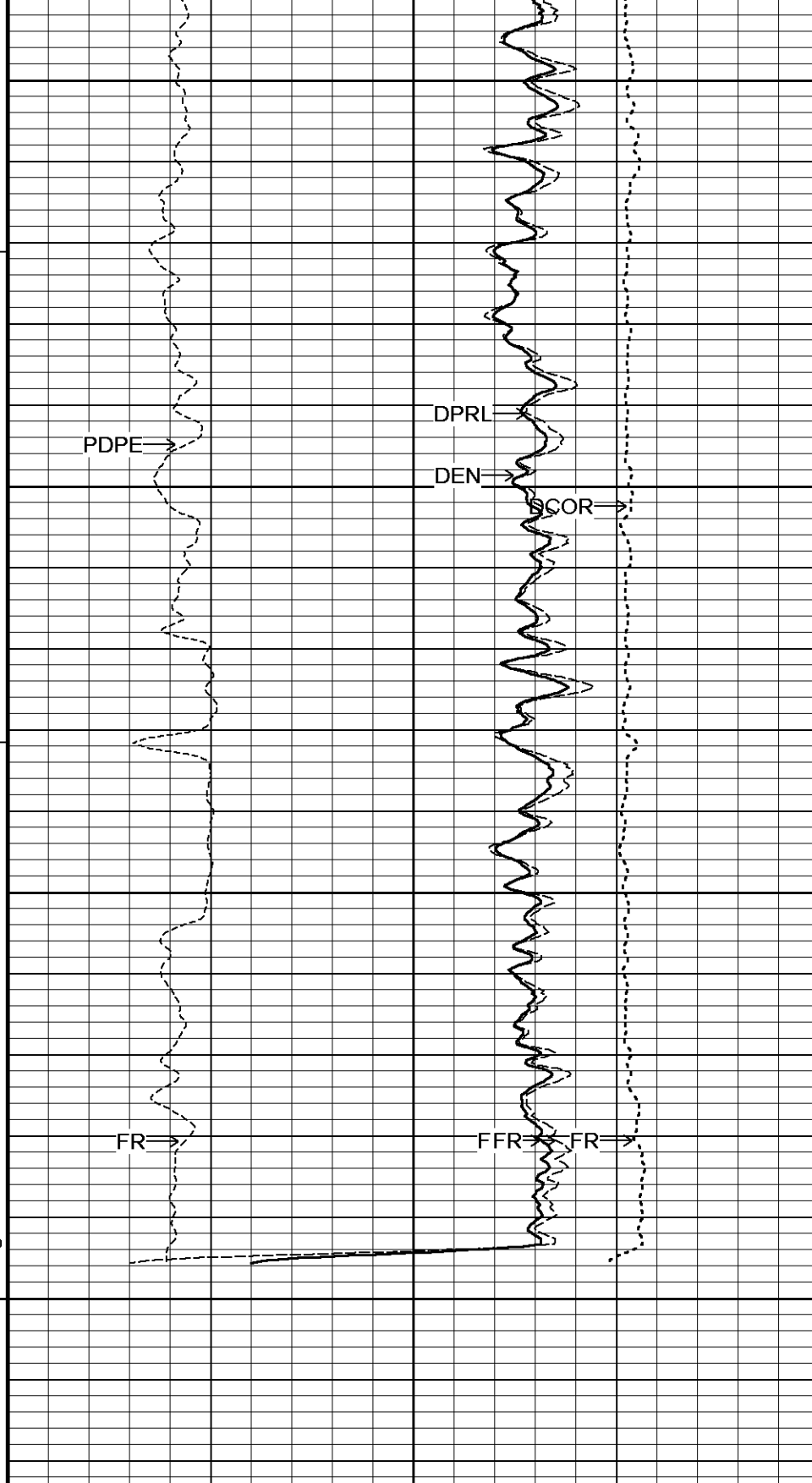
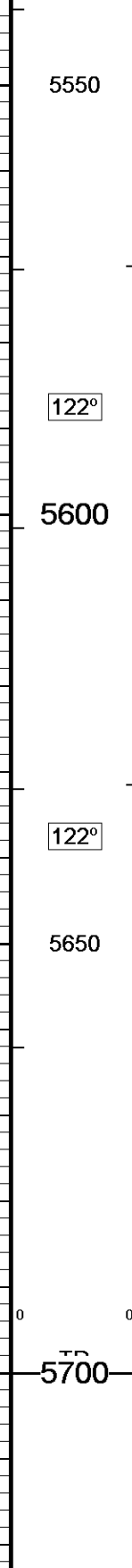
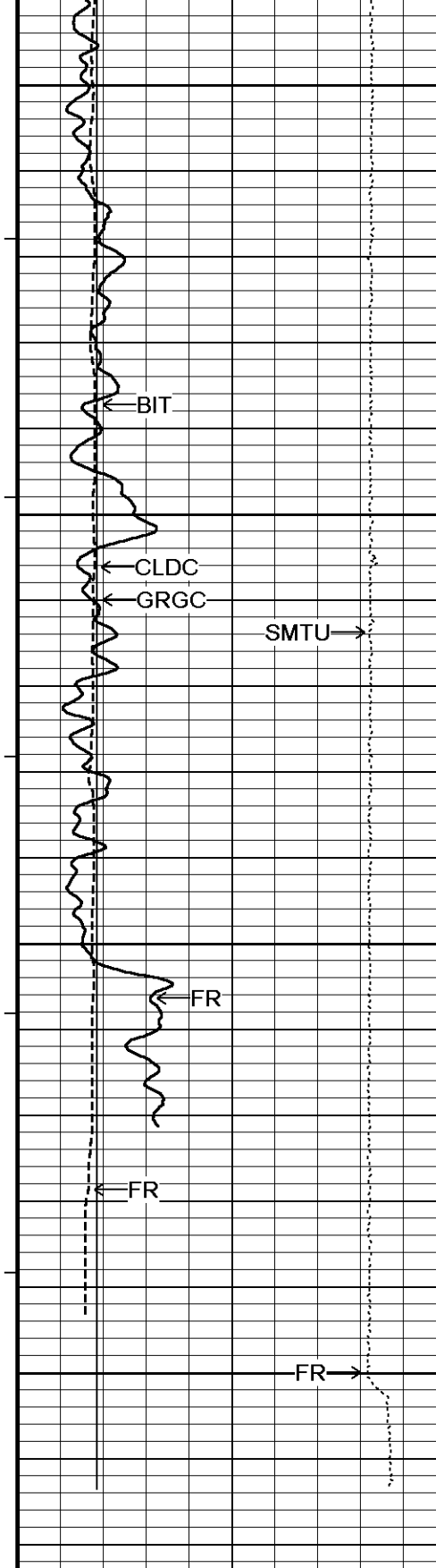

← Timing Marks every 60.0 sec

Gamma Ray  
API  
0 75 150

Depth in Feet

Compensated Density  
grams/cc  
2 2.25 2.50 2.75 3

Borehole Temp in deg F



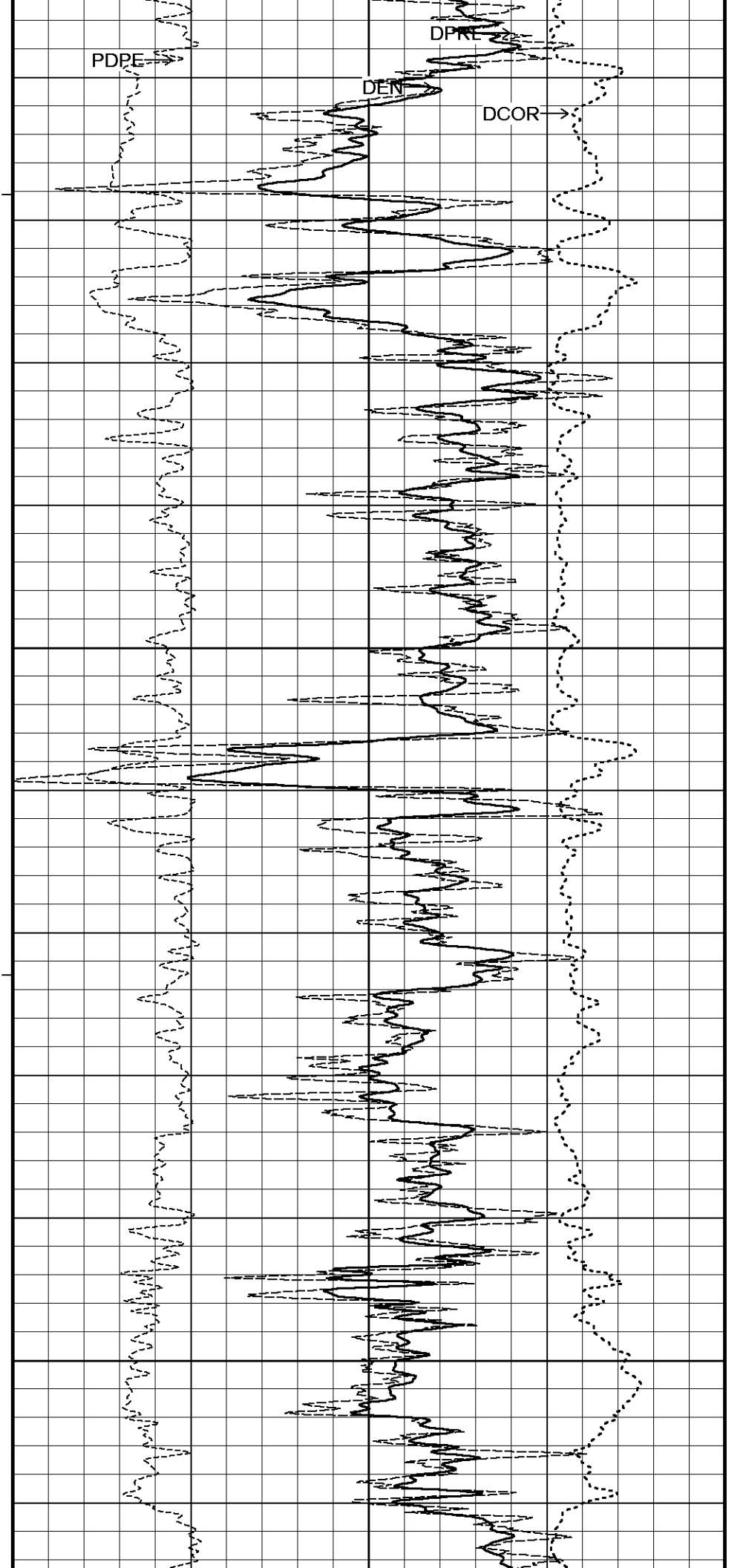
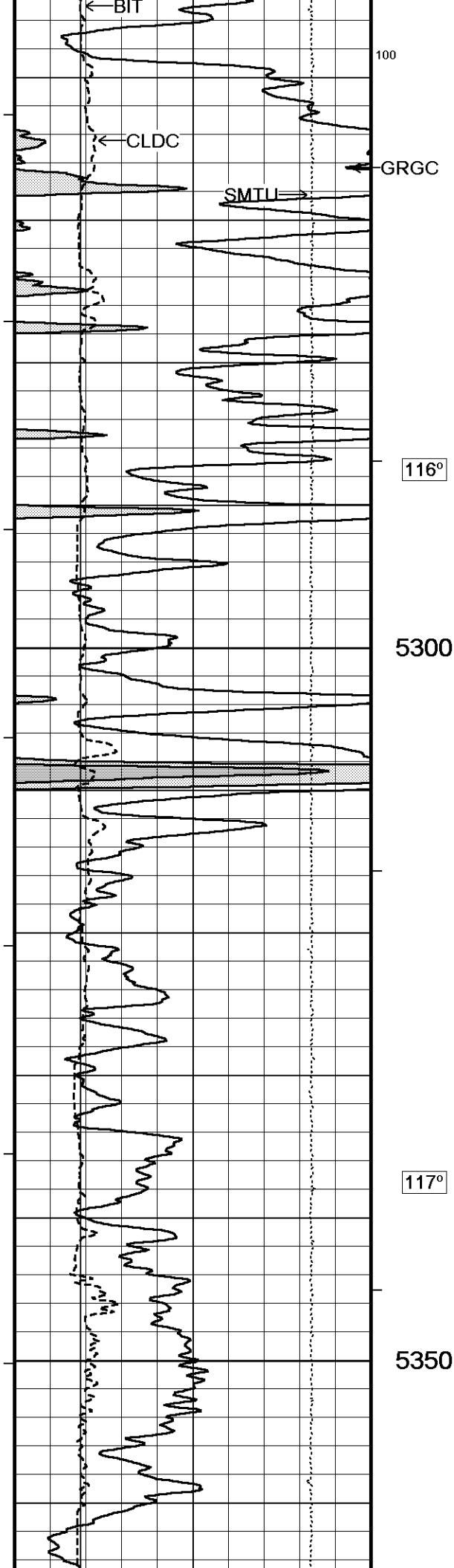

118°

5400

118°

5450

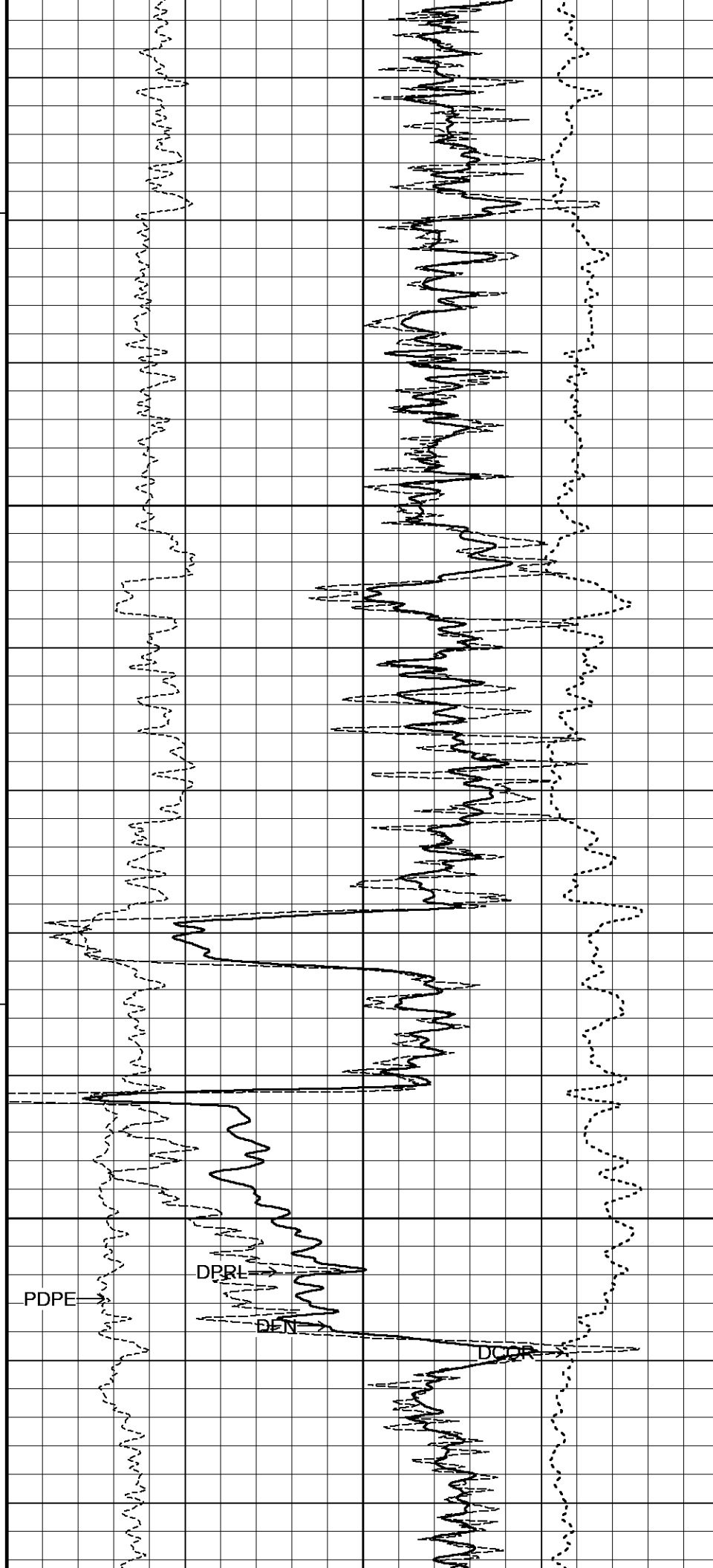
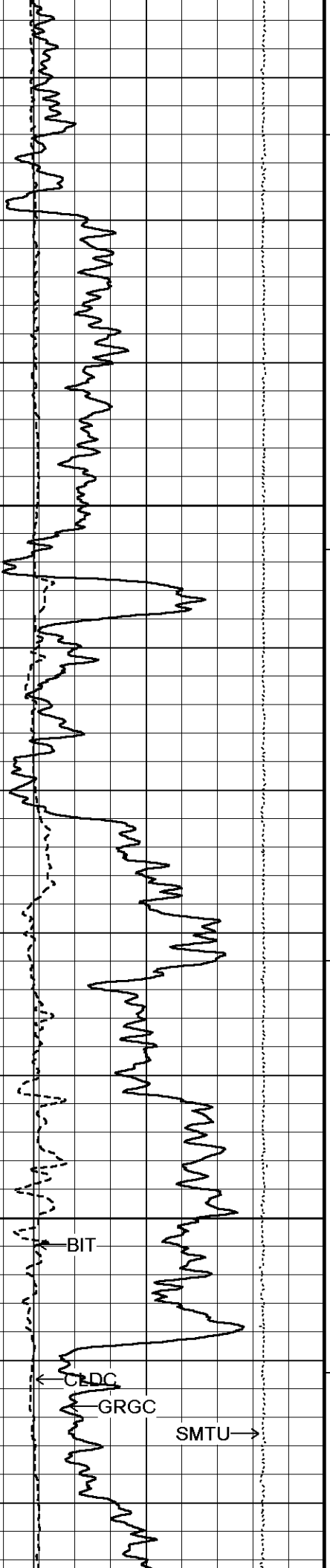

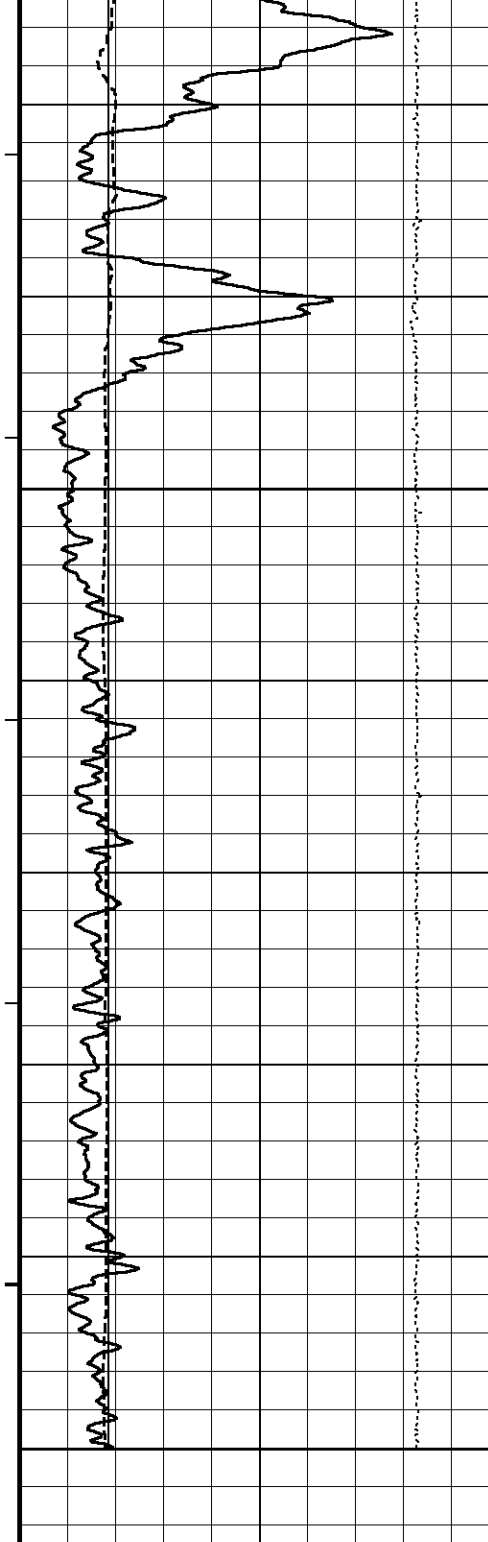

119°

5500

119°

5550

Depth  
in  
Feet

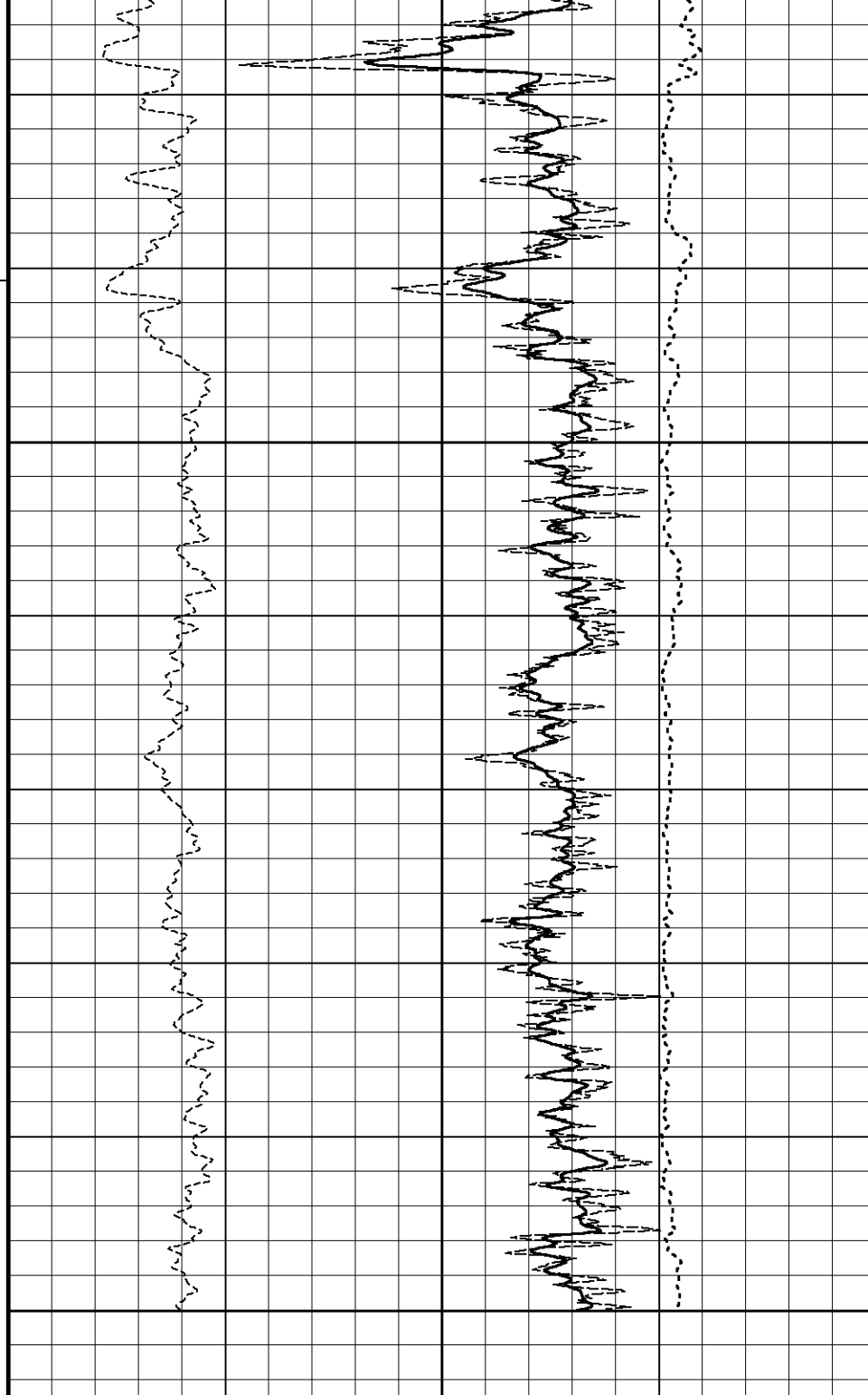

Compensated Density

grams/cc

2                      2.25                      2.50                      2.75                      3

Limestone Density Por.

percent

30                      20                      10                      0                      -10

Timing Marks  
every 60.0 sec

Gamma Ray

API

0                      75                      150  
150                      225                      300

Density Caliper  
inches

6                      11                      16

Borehole  
Temp in  
deg F

HVI  
every  
10 cu ft

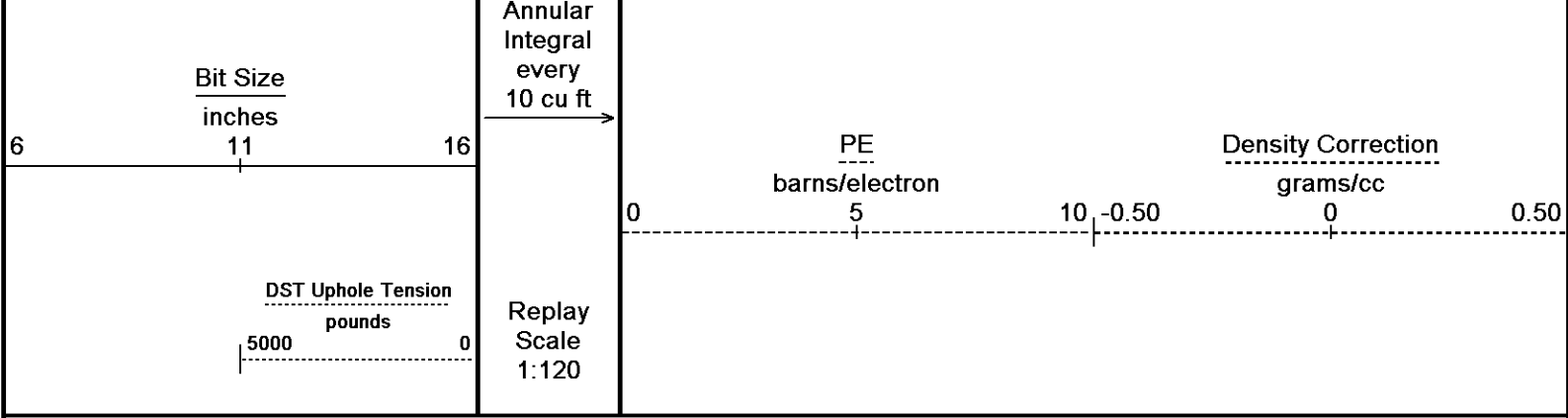

Depth Based Data - Maximum Sampling Increment 2.5cm  
 Plotted on 01-NOV-2014 04:56  
 Filename: C:\Minimus 14.03.4558\Logs\McCoy UMCC 'A' #2-17\McCoy UMCC 'A' #2-17\_002.dta  
 Recorded on 01-NOV-2014 01:41  
 System Versions: Logged with 14.03.4558 Plotted with 14.03.4558

↑ 10 INCH HIGH RESOLUTION ↑

↓ REPEAT SECTION ↓  
 Depth Based Data - Maximum Sampling Increment 10.0cm  
 Plotted on 01-NOV-2014 04:56  
 Filename: C:\Minimus 14.03.4558\Logs\McCoy UMCC 'A' #2-17\McCoy UMCC 'A' #2-17\_003.dta  
 Recorded on 01-NOV-2014 01:41  
 System Versions: Logged with 14.03.4558 Processed with 14.03.4558 Plotted with 14.03.4558

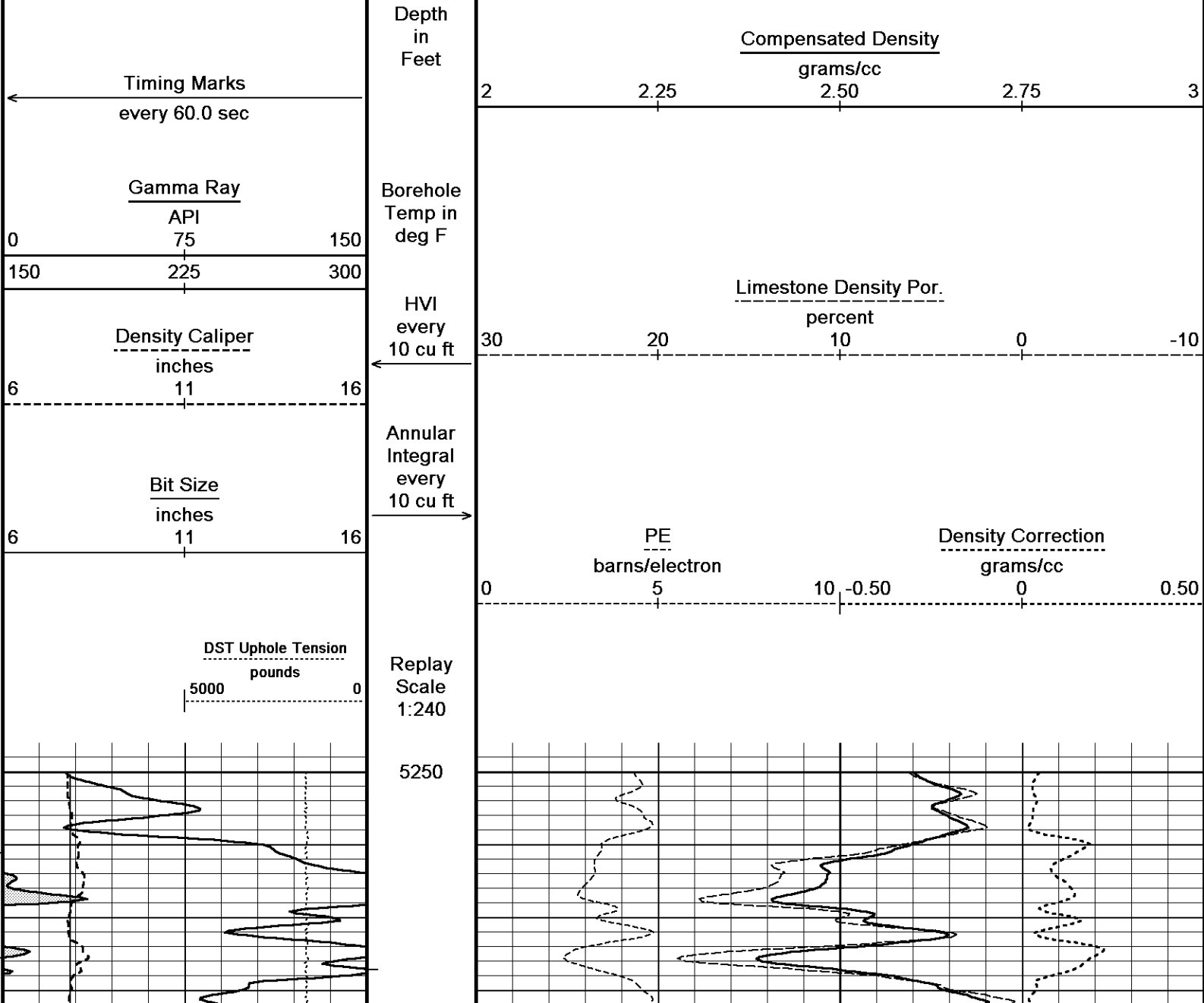

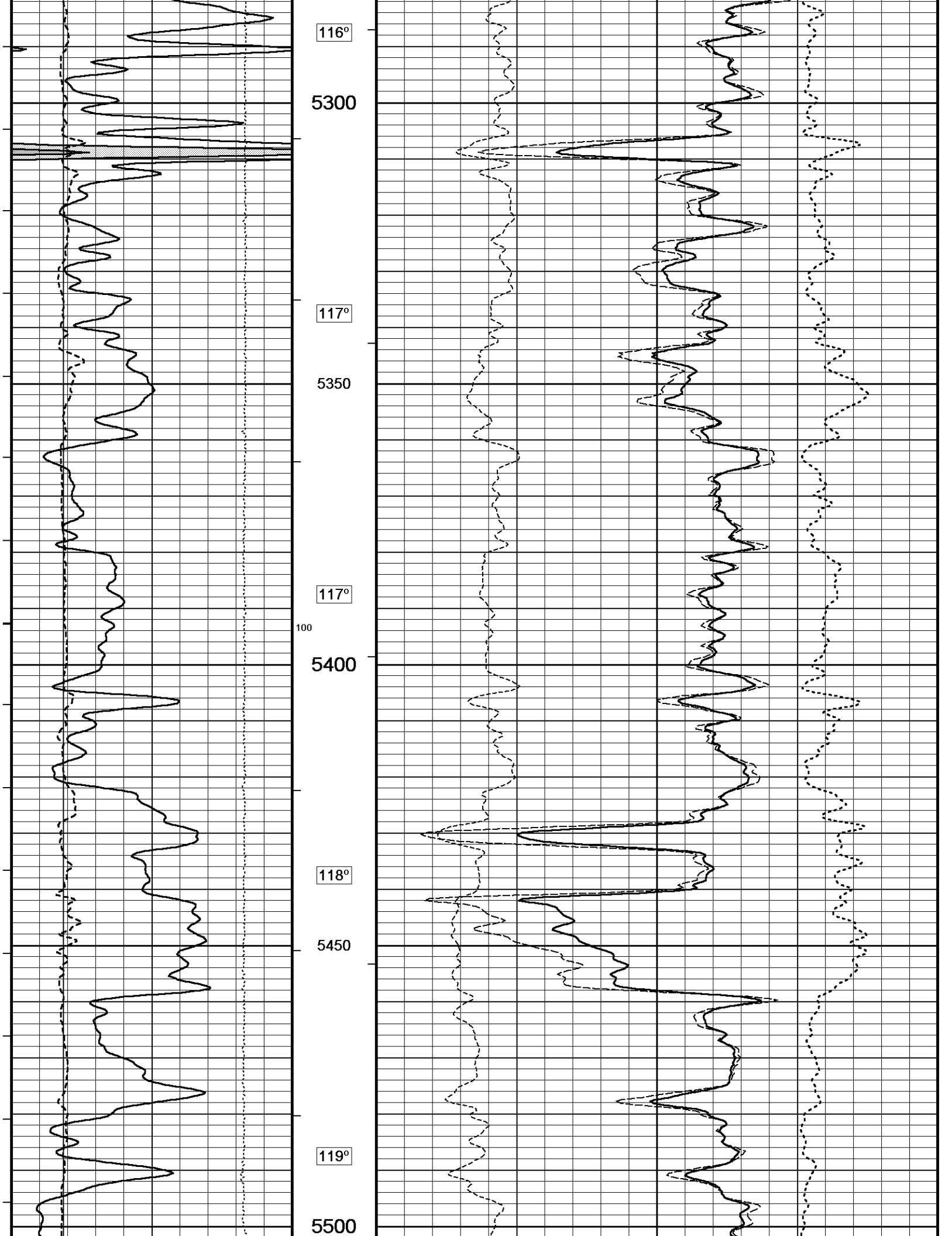



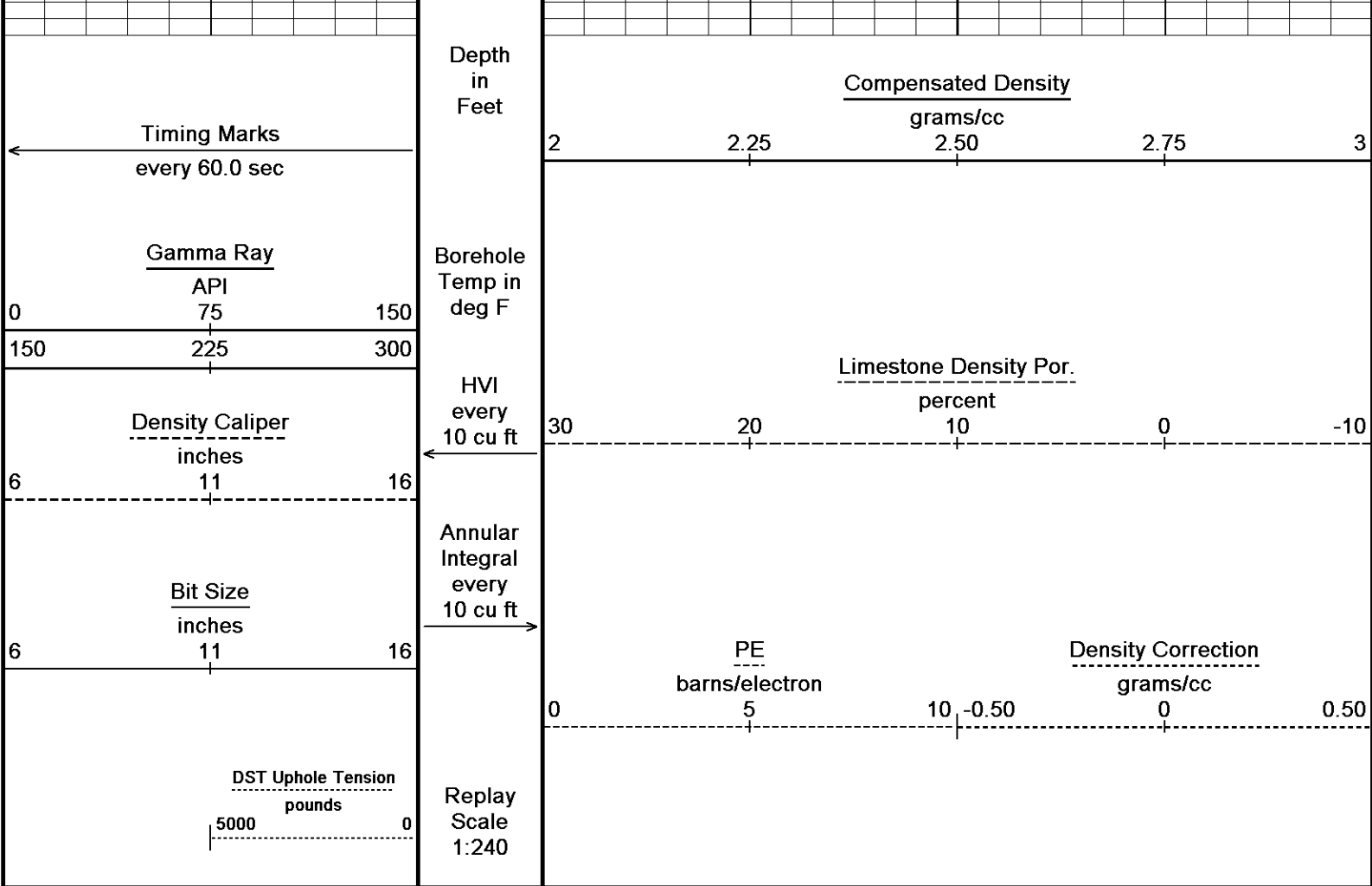

Depth Based Data - Maximum Sampling Increment 10.0cm Plotted on 01-NOV-2014 04:56  
 Filename: C:\Minimus 14.03.4558\Logs\McCoy UMCC 'A' #2-17\McCoy UMCC 'A' #2-17\_003.dta Recorded on 01-NOV-2014 01:41  
 System Versions: Logged with 14.03.4558 Processed with 14.03.4558 Plotted with 14.03.4558

↑ **REPEAT SECTION** ↑

**BEFORE SURVEY CALIBRATION**  
 C:\Minimus 14.03.4558\Logs\McCoy UMCC 'A' #2-17\McCoy UMCC 'A' #2-17\_003.dta

General Constants All 000 Last Edited on 01-NOV-2014,01:00

**General Parameters**

Mud Resistivity	0.980	ohm-metres
Mud Resistivity Temperature	86.000	degrees F
Water Level	0.000	feet
Borehole Fluid Processing	Wet Hole	

**Hole/Annular Volume and Differential Caliper Parameters**

HVOL Method	Single Caliper	
HVOL Caliper 1	Density Caliper	
HVOL Caliper 2	N/A	
Annular Volume Diameter	5.500	inches
Caliper for Differential Caliper	None	

**Rwa Parameters**

Porosity used	Crossplot Porosity	
Resistivity used	Array Ind. Four Res Rt	
RWA Constant A	0.610	
RWA Constant M	2.150	
SW/APOR Tool Source	0.000	

Down-hole Tension Calibration SMS 0 Field Calibration on 30-OCT-2014 14:32

Reading No	Measured	Calibrated (lbs)
1	15642.77	0.00

## Gamma Calibration MCG-C 208

Field Calibration on 31-OCT-2014 14:55

	Measured	Calibrated (API)
Background	77	53
Calibrator (Gross)	1129	778
Calibrator (Net)	1052	725

## Gamma Calibration Tolerances MCG-C 208

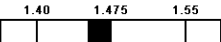
Ratio 1.451  Counts/API

## Gamma Constants MCG-C 208

Last Edited on 31-OCT-2014,22:00

Gamma Calibrator Number	GRC038	
GRC-M Calibrator Jig in Use?	NO	
Inactive Background Jig in Use?	NO	
Mud Density	1.10	gm/cc
Caliper Source for Processing	Density Caliper	
Tool Position	Eccentred	
Concentration of KCl		kppm
K Mud Type	Chloride	
K Mud Concentration	0.00	%

## SP Calibration MCG-C 208

Field Calibration on 28-OCT-2014 16:26

	Measured	Calibrated (mV)
Reference 1	100.0	99.2
Reference 2	-98.0	-99.0

## High Resolution Temperature Calibration MCG-C 208

Field Calibration on 23-SEP-2014,19:44

	Measured	Calibrated(Deg F)
Lower	10.00	10.00
Upper	100.00	100.00

## High Resolution Temperature Constants MCG-C 208

Last Edited on 23-SEP-2014,19:44

Pre-filter Length 11

## Caliper Calibration MMR-C.A 248

Base Calibration on 23-OCT-2014 09:52

Field Calibration on 31-OCT-2014 13:42

Base Calibration Reading No	Measured	Calibrator Size (in)
1	13737	5.96
2	17108	7.98
3	20397	9.85
4	24360	11.92
5	0	0.00
6	N/A	N/A

Field Calibration	Measured Caliper (in)	Actual Caliper (in)
	8.02	7.97

## Caliper Calibration Tolerances MMR-C.A 248

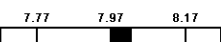
Short Arm Field Cal. 8.02  in

## Micro Normal and Micro Inverse Calibration MMR-C.A 248

Base Calibration on 23-OCT-2014 10:02

Field Check on 30-OCT-2014 10:19

Base Calibration		Measured		Calibrated (ohm-m)	
Channel	Resistor	1	2	Resistor 1	Resistor 2
Micro Normal		10.2	49.9	5.1	25.6
Micro Inverse		9.9	49.5	3.4	16.9
Channel	Base Check (ohm-m)		Field Check (ohm-m)		
Micro Normal			93.5	93.5	
Micro Inverse			62.2	62.2	

## Micro Normal &amp; Micro Inverse Calibration Tolerance MMR-C.A 248

Micro Normal Res. 1	10.2		ohm
Micro Inverse Res. 1	9.9		ohm
Micro Normal Base Check	93.5		ohm-m
Micro Inverse Base Check	62.2		ohm-m
Micro Normal Field Check	93.5		ohm-m
Micro Inverse Field Check	62.2		ohm-m

Micro Normal Res. 2	49.9		ohm
Micro Inverse Res. 2	49.5		ohm

**Micro Normal and Micro Inverse Constants MMR-C.A 248** Last Edited on 19-SEP-2014,16:14

Pad Type	8-12 in Soft Rubber Inflatable 006-9011-159		
Micro Normal K Factor	0.5110		
Micro Inverse K Factor	0.3380		
Standoff Offset	0.0000	inches	

**Micro-Resistivity Caliper Constants MMR-C.A 248** Last Edited on

Sonde Configuration	Resistivity Mode
---------------------	------------------

**Micro Laterolog Calibration MMR-C.A 248** Base Calibration on 31-DEC-1999 00:00  
Field Check on 31-DEC-1999 00:00

Base Calibration				
	Measured		Calibrated (ohm-m)	
	Ref 1	Ref 2	Ref 1	Ref 2
	0.0	0.0	0.0	0.0
	Base Check (ohm-m)		Field Check (ohm-m)	
	0.0		0.0	

**Micro Laterolog Constants MMR-C.A 248** Last Edited on 23-SEP-2014,18:59

Pad Type	6 in Solid Nylon B23059		
Micro Laterolog K Factor	0.0128		
Standoff Offset	0.0000	inches	

Mudcake Thickness Correction Constants			
Mud Cake Source	Constant Value		
Mud Cake Thickness	0.4000	inches	
Mud Cake Thickness Caliper	N/A		
Mud Cake Resistivity	0.1500	ohm-m	
Mud Cake Resistivity Temp.	68.00	Deg F	
Mud Cake Resistivity Source	Constant Value		
Temp. Source Rmc Correc.	N/A		

**Neutron Calibration MDN-A.B 163** Base Calibration on 22-OCT-2014 17:32  
Field Check on 31-OCT-2014 15:01

Base Calibration				
	Measured		Calibrated (cps)	
	Near	Far	Near	Far
	3042	93	3714	110
Ratio	32.627		33.764	
Field Calibrator at Base				
			Calibrated (cps)	
			1687	2482
Ratio	0.680			
Field Check				
			Calibrated (cps)	
			1689	2455
Ratio	0.688			

**Neutron Calibration Tolerances MDN-A.B 163**

Near Reading	3042		cps	Far Reading	93		cps
Ratio	32.627						
Base Check	0.680						

Field Check

0.688



## Neutron Constants MDN-A.B 163

Last Edited on 31-OCT-2014,22:00

Neutron Source Id	P58125B	
Neutron Jig Number	5824NE	
Air Hole Processing	Legacy	
Caliper Source for Processing	Density Caliper	
Stand-off	0.00	inches
Mud Density	1.00	gm/cc
Limestone Sigma	7.10	cu
Sandstone Sigma	4.26	cu
Dolomite Sigma	4.70	cu
Formation Pressure Source	None	
Formation Pressure	N/A	kpsi
Temperature Source	Constant Value	
Temperature	68.00	degrees F
Mud Salinity	0.00	kppm
Salinity Correction	Not Applied	
Formation Fluid Salinity Source	None	
Formation Fluid Salinity	N/A	kppm
Barite Mud Correction	Not Applied	

## FE Calibration MFE-A.A 55

Base Calibration on 23-OCT-2014 09:18

Field Check on 31-OCT-2014 13:33

## Base Calibration

	Measured	Calibrated (ohm-m)
Reference 1	0.0	0.0
Reference 2	950.6	126.8
Base Check		282.0
Field Check		281.8

## FE Calibration Tolerances MFE-A.A 55

Reference 2	950.6	ohm
Base Check	282.0	ohm-m
Field Check	281.8	ohm-m

## FE Constants MFE-A.A 55

Last Edited on 31-OCT-2014,21:59

Running Mode	No Sleeve	
MFE K Factor	0.1268	
Caliper Source for FE correction	Density Caliper	
Caliper Value for FE correction	N/A	inches
Rm Source for FE correction	Temperature Corr	
Temp. for Rm Corr.	MCG External Temperature	
Stand-off	0.5	inches

## Induction Calibration MAI-A.A 5

Base Calibration on 22-OCT-2014,13:28

Field Check on 31-OCT-2014 13:32

## Base Calibration

Test Loop Calibration Channel	Measured		Calibrated (mmho/m)	
	Low	High	Low	High
1	16.3	470.8	9.3	966.2
2	5.6	376.1	7.6	821.4
3	2.6	266.1	5.2	566.0
4	1.6	130.0	2.6	279.2
Array Temperature	71.1		Deg F	

## Test Loop Calibration Verified

Channel	Base Check (mmho/m)		Field Check (mmho/m)	
	Low	High	Low	High
1	0.0	0.0	14.6	3863.4
2	0.0	0.0	31.6	3591.3
3	0.0	0.0	29.7	2971.7

4	0.0	0.0	20.7	2126.5
Deep			18.4	1912.3
Medium			42.9	3861.6
Shallow			47.0	5373.5

Array Temperature 0.0 65.9 Deg F

Induction Calibration Tolerances MAI-A.A 5

Low Conductivity 1	16.3		mmho/m	High Conductivity 1	470.8		mmho/m
Low Conductivity 2	5.6		mmho/m	High Conductivity 2	376.1		mmho/m
Low Conductivity 3	2.6		mmho/m	High Conductivity 3	266.1		mmho/m
Low Conductivity 4	1.6		mmho/m	High Conductivity 4	130.0		mmho/m
Background Vx 1	0.0		mmho/m	Phase Check Loop 1	0.0		%
Background Vx 2	0.0		mmho/m	Phase Check Loop 2	0.0		%
Background Vx 3	0.0		mmho/m	Phase Check Loop 3	0.0		%
Background Vx 4	0.0		mmho/m	Phase Check Loop 4	0.0		%

Induction Constants MAI-A.A 5

Last Edited on 31-OCT-2014,21:59

Induction Model	RtAP-WBM		
Caliper for Borehole Corr.	Density Caliper		
Hole Size for Borehole Correction	2.500	inches	
Tool Centred	No		
Stand-off Type	Fins		
Stand-off	0.50	inches	
Number of Fins on Stand-off	8.0000		
Stand-off Fin Angle	45.00	degrees	
Stand-off Fin Width	0.5000	inches	
Borehole Corr. Rm Source	Temperature Corr		
Temp. for Rm Corr.	MCG External Temperature		
Squasher Start	0.0020	mhos/metre	
Squasher Offset	N/A	mhos/metre	
Borehole Normalisation			
DRM1	0.0000	DRC1	0.0000
DRM2	0.0000	DRC2	0.0000
MRM1	0.0000	MRC1	0.0000
MRM2	0.0000	MRC2	0.0000
SRM1	0.0000	SRC1	0.0000
SRM2	0.0000	SRC2	0.0000
Calibration Site Corrections			
Channel 1	0.00	mmhos/metre	
Channel 2	0.00	mmhos/metre	
Channel 3	0.00	mmhos/metre	
Channel 4	0.00	mmhos/metre	
Apparent Porosity and Water Saturation Constants			
Archie Constant (A)	1.00		
Cementation Exponent (M)	2.00		
Saturation Exponent (N)	2.00		
Saturation of Water for Apor	100.00	percent	
Resistivity of Water for Apor and Sw	0.05	ohm-m	
Resistivity of Mud Filtrate for Sw	0.00	ohm-m	
Source for Rt	0.00		
Source for Rxo	0.00		

High Resolution Temperature Calibration MAI-A.A 5

Field Calibration on 01-NOV-2014,01:00

	Measured	Calibrated(Deg F)
Lower	10.00	10.00
Upper	100.00	100.00

High Resolution Temperature Constants MAI-A.A 5

Last Edited on 01-NOV-2014,01:00

Pre-filter Length 11

Density Calibration

Base Calibration	Measured		Calibrated (sdu)	
	Near	Far	Near	Far
Background	1210	1421		
Reference 1	55376	26233	59556	30836
Reference 2	22300	2596	24941	2541

Field Check at Base  
1210.3 1420.8

Field Check  
1209.7 1418.0

PE Calibration

Base Calibration	WS	Measured		Calibrated Ratio
		WH	Ratio	
Background	227	1078		
Reference 1	23980	55175	0.439	0.371
Reference 2	6780	22159	0.311	0.272

Field Check at Base  
226.9 1078.0

Field Check  
229.8 1081.8

Photo Density Calibration Tolerances MPD-D.A 481

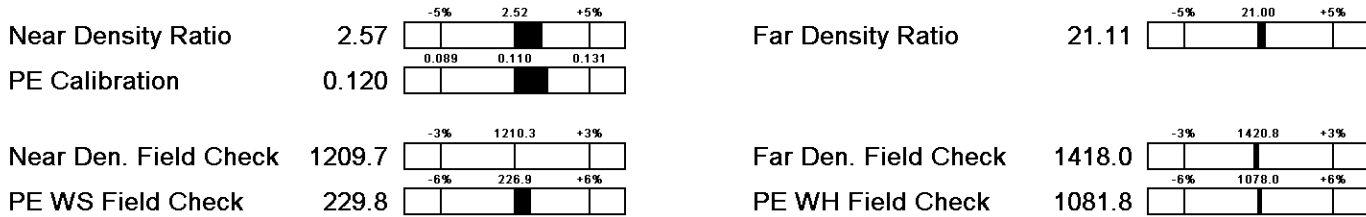

Density Constants MPD-D.A 481

Last Edited on 31-OCT-2014,22:00

Density Source Id	P50557B	
Nylon Calibrator Number	DNCE695	
Aluminium Calibrator Number	DACD698	
Density Shoe Profile	8 inch	
Caliper Source for Processing	Density Caliper	
PE Correction to Density	Not Applied	
Mud Density	1.10	gm/cc
Mud Density Z/A Multiplier	1.11	
Mud Filtrate Density	1.00	gm/cc
Dry Hole Mud Filtrate Density	1.00	gm/cc
DNCT	0.00	gm/cc
CRCT	0.00	gm/cc
Density Z/A Correction	Hybrid	
Matrix density (gm/cc)	Depth (m)	
2.71	0.00	
0.00	0.00	
0.00	0.00	
0.00	0.00	
0.00	0.00	
0.00	0.00	
0.00	0.00	
0.00	0.00	

Caliper Calibration MPD-D.A 481

Base Calibration on 22-OCT-2014 15:01  
Field Calibration on 31-OCT-2014 13:35

Base Calibration	Measured	Calibrator Size (in)
Reading No		
1	17509	3.99
2	27597	5.98
3	37616	7.97
4	47437	9.86

5  
6

58570  
N/A

11.92  
N/A

Field Calibration

Measured Caliper (in)  
7.98

Actual Caliper (in)  
7.97

Caliper Calibration Tolerances MPD-D.A 481

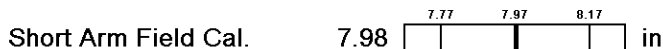

DOWNHOLE EQUIPMENT

C:\Minimus 14.03.4558\Logs\McCoy UMCC 'A' #2-17\McCoy UMCC 'A' #2-17\_003.dta

- CBH-C, Cablehead, 11 pin  
CBH-C 0 LG: 2.40 ft WT: 24.3 lb OD: 2.244 in
- Compact Comms Gamma  
MCG-C 208 LG: 8.70 ft WT: 63.9 lb OD: 2.244 in
- Compact Micro-Resistivity  
MMR-C.A 248 LG: 8.59 ft WT: 81.6 lb OD: 4.882 in
- Compact Neutron  
MDN-A.B 163 LG: 5.04 ft WT: 50.7 lb OD: 2.244 in
- Compact Density/Caliper  
MPD-D.A 481 LG: 9.59 ft WT: 90.4 lb OD: 2.449 in
- Compact Focussed Electric  
MFE-A.A 55 LG: 6.05 ft WT: 48.5 lb OD: 2.244 in
- Compact Induction  
MAI-A.A 5 LG: 10.81 ft WT: 48.5 lb OD: 2.244 in
- Total Length: 51.18 ft Weight: 407.9 lb

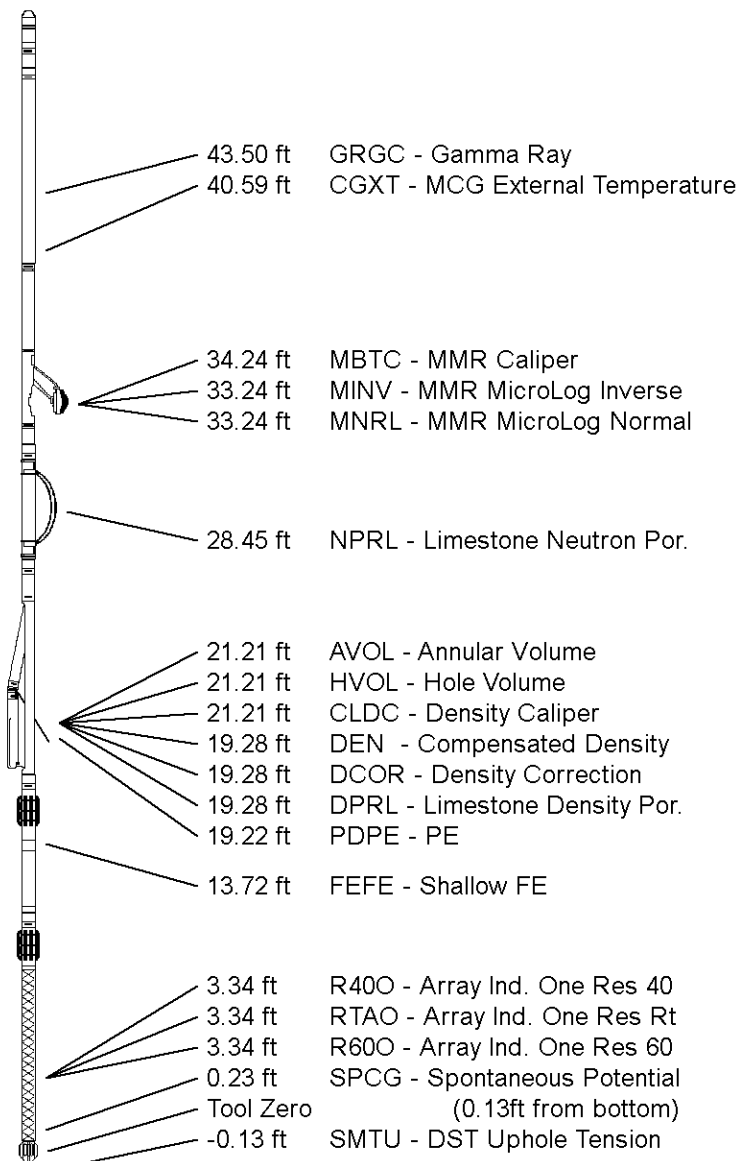

COMPANY McCOY PETROLEUM CORPORATION  
 WELL UMCC 'A' #2-17  
 FIELD WILDCAT  
 PROVINCE/COUNTY MEADE  
 COUNTRY/STATE U.S.A. / KANSAS

Elevation Kelly Bushing	2830.00	feet	First Reading	5681.00	feet
Elevation Drill Floor	2828.00	feet	Depth Driller	5700.00	feet
Elevation Ground Level	2819.00	feet	Depth Logger	5700.00	feet



**Weatherford**<sup>®</sup>

COMPACT PHOTO DENSITY  
COMPENSATED NEUTRON  
MICRORESISTIVITY LOG